

Regulator Information Sheet

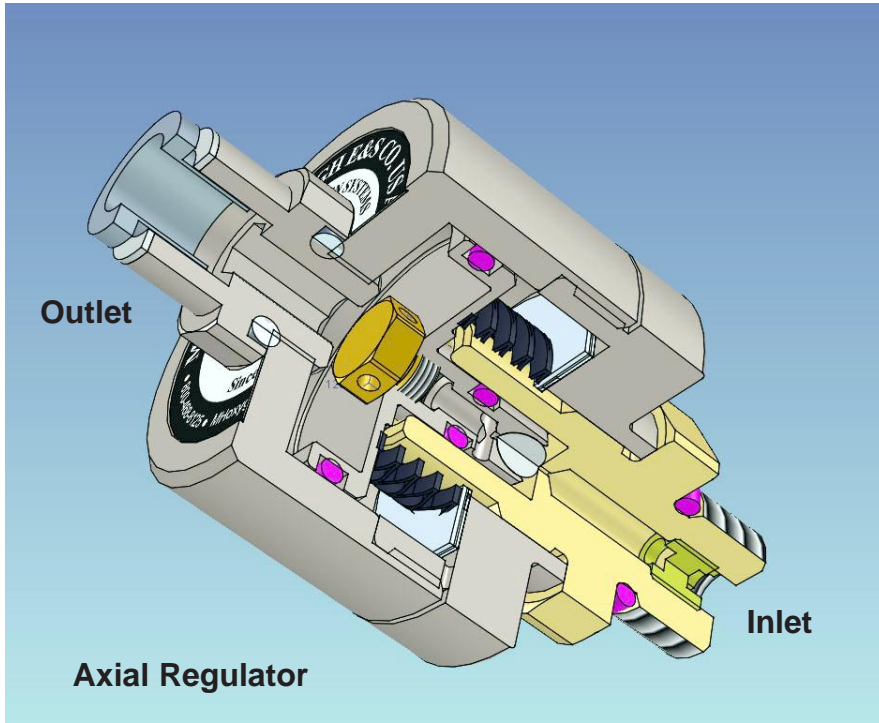

All of our regulator types are designed and built in the USA by Mountain High.



Regulator Features Include:

- > Very constant lock-up and flowing pressure range and large flow reserve throughout the pressure life of the cylinder. Light weight aluminum body with oxygen compatible brass and seat materials in the critical wetted regulating/throttling high-pressure areas.
- > Wide operating temperature range. -20 to +50 C°. Special flat-wire double-helix spring design complements the gas dynamics and aging characteristics of the inlet seat to provide lock-up to dynamic pressures that are unusually tightly matched for a piston type regulator designs throughout it's service life.
- > Our unique ball-and-flat-seat design provides very fast response times to lock-up with an oscillation-free high flow factor specifically designed for use with pulse demand systems.

Testing & Verification:

All of our regulators are 100% tested during assembly for multiple parameters before they are packaged and made ready for sale. Dynamic flow testing is performed with the regulator feeding through a mass-flow meter at the end of 20 feet of 6mm O.D. 4mm ID tubing to guarantee that the regulator will operate up to four EDS units at 18,000 ft. with a cylinder pressure as low as 500 psig.

20' is the typical length of tubing used in most built-in applications. Portable systems have a typical length of 39" between the system and the user.

Therefore, actual flow performance will usually be better at lower cylinder pressures.

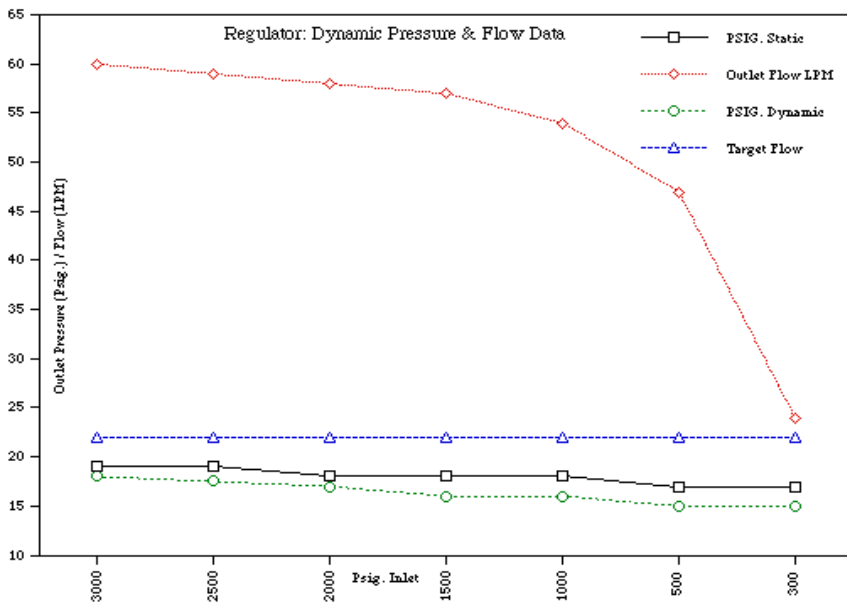
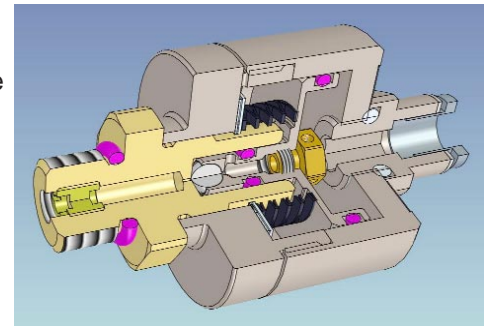

Our regulators have a virtually flat outlet pressure regulation curve for both lock-up (static) and flowing (dynamic) with inlet pressures from 300 to 3,000 psig. In open and closed-loop instantaneous flow tests, they have very well dampened, oscillation free flows. Flows of 55 to 60 liters/minute are measured through a controlled pneumatic resistance with inlet pressures of 1,000 to 3,000 psig. Target flows are 22 ±2 liters/minute throughout the inlet pressure range of 500 to 3,000 psig.

EDS units only need to have the regulator that instantaneously delivers ~10 liters/minute to complement the needed amount of oxygen for pressure altitudes up to 18,000 ft.

Why a piston type regulator, why not a diaphragm type as seen in medical equipment?

Piston-type compressed gas regulators are well known for being low-cost, rugged, light-weight and able to be serviced with standard assembly practices. Additionally, they have the ability to ingest small particles at extreme temperatures while performing well within specifications called out for their duty. Their simplicity provides the means to a quick diagnostic and repair even in the field.

Diaphragm regulators are known more for their precision and high-cost but, are sensitive to harsh environments making them more suited for stationary and controlled indoor applications. Because they usually do not have suitable lock-up to flow pressure characteristics, are larger and heavier, they are usually unsuitable for pulse-demand systems.