

REVISION HISTORY			
REV	MO-DA-YR	E. C. O. / APPR.	NOTES
-	06-20-10	PLM	INITIAL ISSUE OF DESMODROMIC VERSION
A	01-30-11	PLM	ADDED DIMENSIONING FOR SWITCH & CORRECTED PTHER DIMS

OPTIONAL REMOTE GAUGE & FILL STATION: AUX HP-1 (SAE-4)

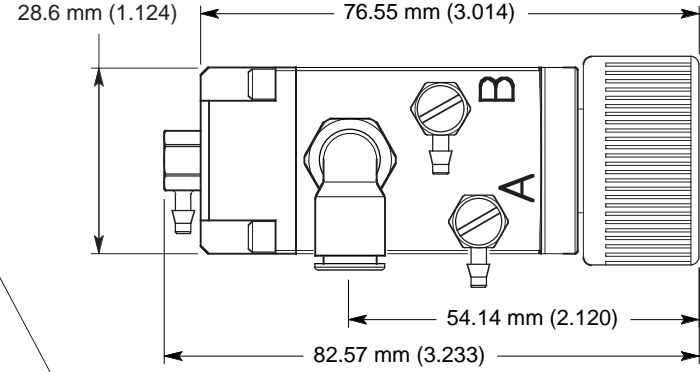

OUTLET PORT: BSPP TO 6 MM ELBOW TUBE OUTLET FITTING

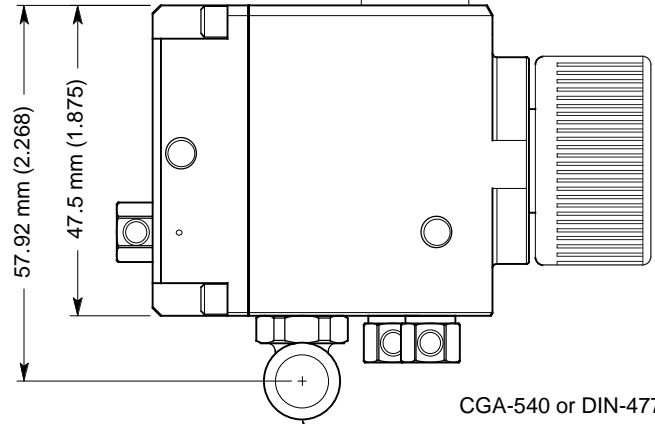
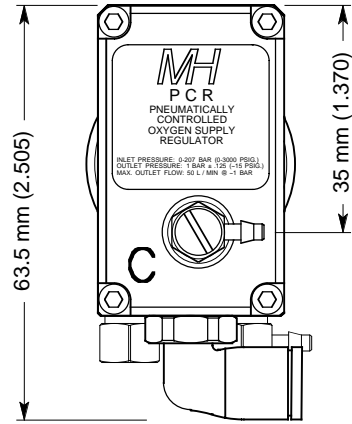
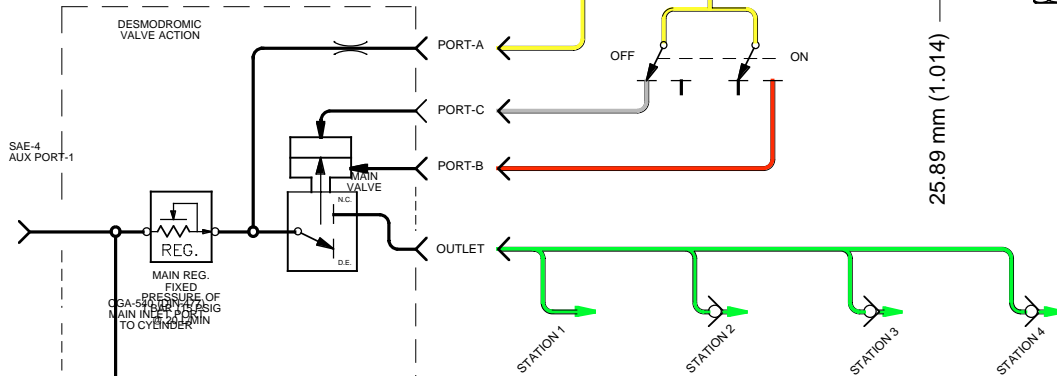
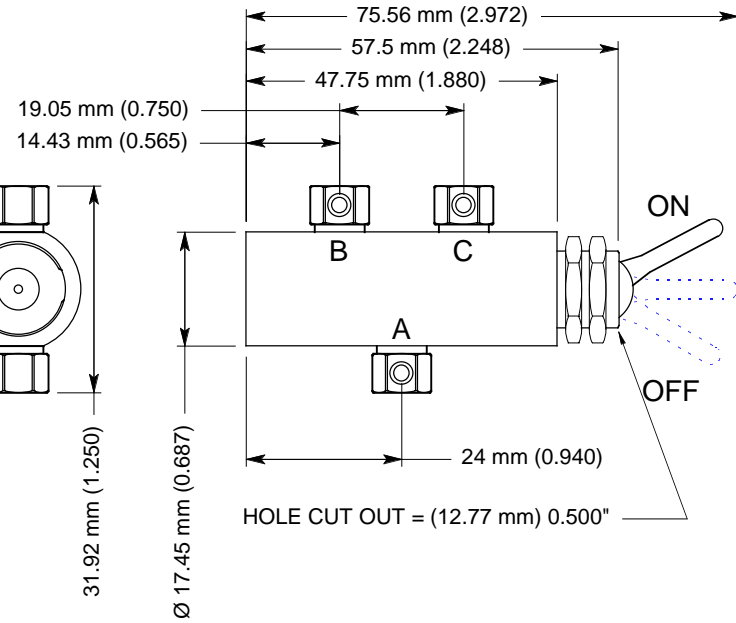

UNLESS OTHERWISE SPECIFIED DIMS ARE IN INCHES. TOLERANCES ARE:		THIRD ANGLE PROJECTION	[KC] NUMBER OF KEY CHARACTERISTICS IN THIS DRAWING / DOCUMENT PER MH DOC: ESR-001
0.X ±0.010	ANGLES ±0.5°	FRACTIONS ±1/64	00
0.XXX ±0.005		63	MOUNTAIN HIGH E&S CO.
0.XXX ±0.002			REDMOND, OR. USA
INTERPRET GD&T PER ASME 14.5 (FMT REV C)			
ISSUED:	MO-DA-YR	PCR DESMODROMIC BASIC Form Factor	
DRAWN: PLM	06-10-10	DWG. #: 0PCR0-0055-00	
ENGINEER: PLM	06-10-10	REV A	
APPR:	DATE	SIZE A	SHEET 1 OF 1
DO NOT SCALE DRAWING			