

DESCRIPTION:

THIS DEVICE IS INTENDED TO BE PLACED INLINE BETWEEN A SOURCE OF OXYGEN AND THE DISPENSING DEVICE TO PROVIDE A VISUAL INDICATION RESULTING FROM A POSITIVE FLOW OF OXYGEN TO THAT DISPENSING DEVICE.

THE SPINNER IS MOUNTED BY A POINTED STEEL AXLE TO PROVIDE A LOW-FRICTION POINT AND AXIAL JEWEL LIKE SUSPENSION WITHIN THE HOUSING. IT IS SPECIFICALLY DESIGNED TO PROVIDE INDICATION OF FLOW WITH A MINIMUM AMOUNT OF IMPEDANCE OF THAT FLOW.

THE SPINNING INDICATOR IS BI-DIRECTIONAL. FLOWING OXYGEN WILL SPIN A CROSS SHAPED WHEEL HOUSED INSIDE THE CLEAR PLASTIC HOUSING. THE MIN. REQUIRED FLOW FOR SPINNING IS ABOUT 1.50 L. PER MIN.

SPINNING WILL INDICATE THAT OXYGEN IS FLOWING. FAILURE TO SPIN WILL ALERT THE USER THAT OXYGEN MAY NOT BE FLOWING.

THE FLOW ADMITTANCE OF THIS DEVICE IS HIGH AND IS INTENDED TO BE USED WITH PULSE DEMAND DELIVERY SYSTEMS. IT MAY NOT OPERATE AT FLOW RATES AT AND BELOW 1 LITER / MIN.

REVISION HISTORY

REV	DATE	E. C. O. / APPR.	NOTES

D

C

B

A

D

C

B

A

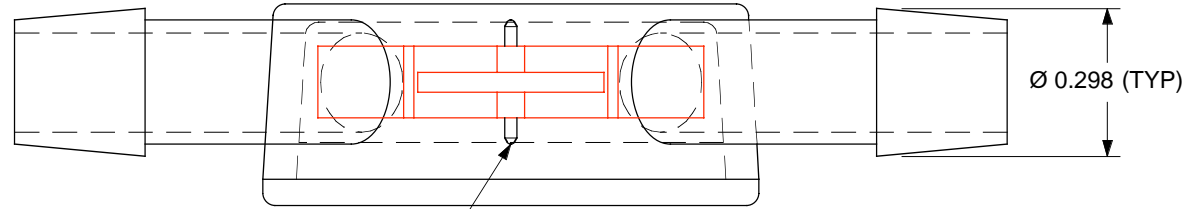
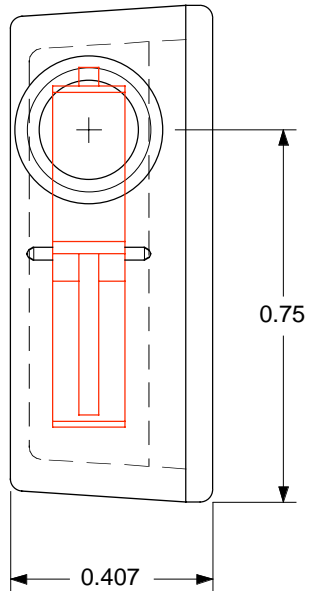

POINTED STEEL AXLE

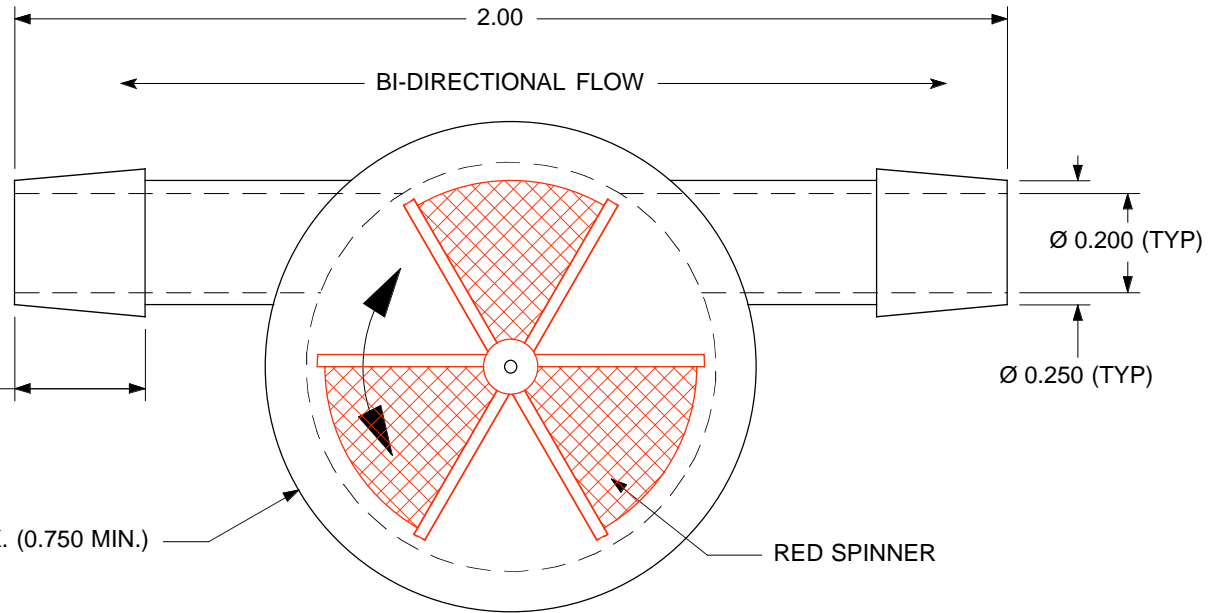

BI-DIRECTIONAL FLOW

RED SPINNER

NOTES:

1. MATERIAL: ABS, TERLUX 2802TR (K-RESIN/HDPE CLEAR) WITH RED SPINNER (OEM)
2. FINISH: NONE
3. CLEAN: UNLESS OTHERWISE SPECIFIED, PER AIR-1176A SEC. 5
4. MARKING: NONE SPECIFIED

UNLESS OTHERWISE SPECIFIED DIMS ARE IN INCHES. TOLERANCES ARE:

0.X	±0.015	ANGLES	FRACTIONS	63
0.XX	±0.010	± 0.5°	± 1/64	
0.XXX	±0.005			

INTERPRET GD&T DIMS AND TOLS PER ASME 14.5

THIRD ANGLE PROJECTION.

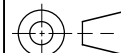

<CR> KEY CHARACTERISTICS

NO.

<MA> PER CORP. DOC: ESR-001

-



MOUNTAIN HIGH
E&S CO.
REDMOND, OR. USA

ISSUED:	DATE	MATERIAL:	NOTE 1	FLOW IND., SPINNER WITH BARBS	
DRAWN:	PLM	11-15-99	FINISH:	NOTE 2	DWG. #: 9210-001
ENGINEER:	PLM	DATE	CLEAN:	NOTE 3	
APPR:	DATE	MARKING:	NOTE 4	SIZE A	SHEET 1 OF 1
					DO NOT SCALE DRAWING

4

3

2

1