

GENERAL SPECIFICATIONS

Material: UNS C36000 (CDA-360) Brass
 UNS A96061 (6061-T6) Aluminum

Weight: 4.8 oz [136 g]

Inlet Fitting: DIN-477-9N
 Outlet Fitting: G-1/8 BSPP x 4mm Tube

Inlet Pressure Rating: 3000 PSI MAX
 Regulated Outlet: 16 ± 2 PSI (Dynamic) (NOM 1 Bar)
 20 ± 2 PSI (Static)

Average Flow Rate: 40 L/min
 Temperature Range: -50°F to +130°F [-45°C to +55°C]

Spare O-ring: MH p/n 09001-3113-70 (DIN-477, Item #6)

REV	ECO	Release	Drawn	REVISION HISTORY
A0	2018-023	2018-08-16	SGO	Customer Reference Drawing

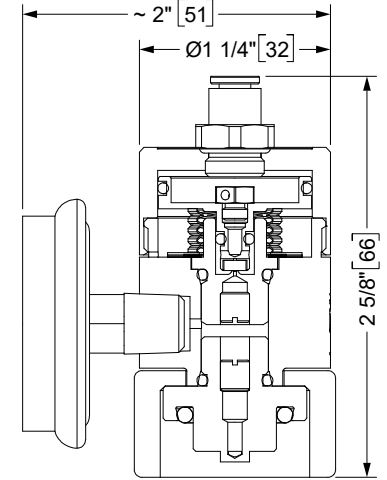

REF	Qty	Description
1	1	Gauge Body
2	1	Grip-Nut, DIN-477-9
3	1	Inlet Nipple, DIN-477-9, Euro-CV Styl
4	2	Filter
5	2	O-Ring
6	2	O-Ring
7	1	Inlet Seat
8	A/R	Shim, .010
9	A/R	Shim, .016
10	A/R	Shim, .020
11	1	Spring
12	1	Diffuser
13	1	Piston
14	1	O-Ring
15	1	O-Ring
16	1	Puck
17	1	Outlet Body, Axial
18	1	Label
19	1	Outlet Fitting, 4mm tube, Straight
20	1	MH-300 Medium Pressure Gauge
21	1	Outlet Fitting, 4mm tube, 90° Elbow

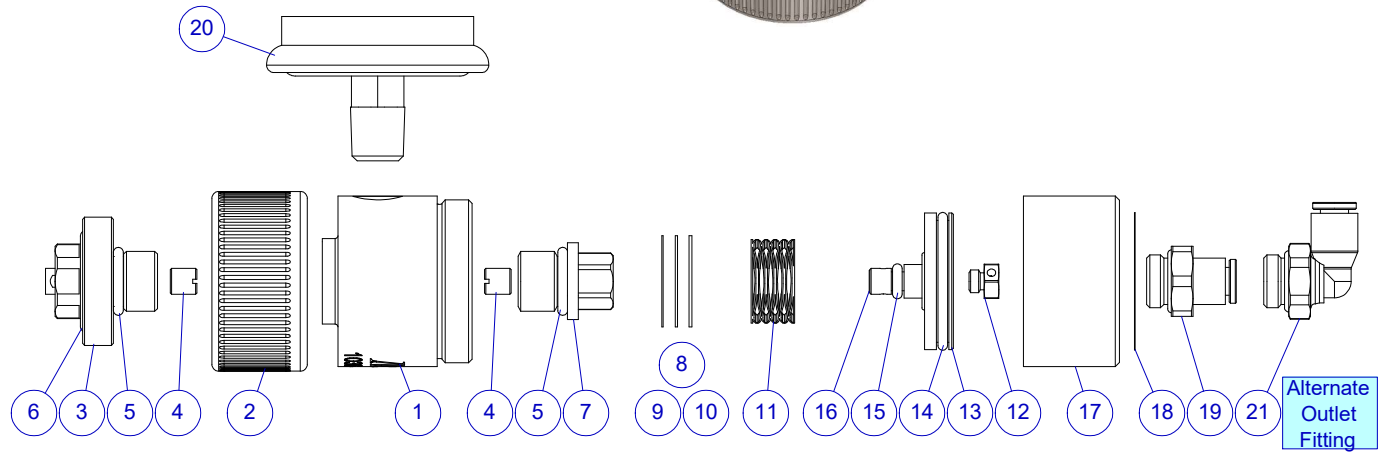

UNLESS OTHERWISE SPECIFIED, DIMENSIONS ARE IN INCHES. TOLERANCES ARE:
 0.X ±0.015
 0.XX ±0.010
 0.XXX ±0.005

ANGLES ± 3°
 FRACTIONS ± 1/64

INTERPRET GD&T PER ASME 14.5

THIRD ANGLE PROJECTION

DO NOT SCALE DRAWING

MOUNTAIN HIGH E&S CO. REDMOND, OR. USA		THIS DOCUMENT AND ALL TECHNICAL DATA HEREON DISCLOSED ARE PROPERTY OF MOUNTAIN HIGH E&S CO. AND SHALL NOT BE USED, RELEASED OR DISCLOSED IN WHOLE OR PART WITHOUT WRITTEN PERMISSION FROM MOUNTAIN HIGH E&S CO. THIS DOCUMENT MUST BE RETURNED TO MOUNTAIN HIGH E&S CO. IMMEDIATELY UPON REQUEST.	
		DWG TITLE: XCR Regulator, DIN-477-9 x 4mm Tube, Axial, w/ Gauge [SCD]	
DWG NUMBER: 5SREG-1036-04		DWG REV: A0	
CAD FILE: 00REG-1036-04\$A0		INV. PART NUMBER: 00REG-1036-04	
APPROVED:		PROD. NAME: XCR-DIN(E)-1P-A-G	
DWG FORMAT: ESR-002 Rev H [20]		DWG SCALE:	
DWG SHEET: 1 OF 1		DWG SIZE: A 11x8 1/2	