

1

2

3

4

Low Profile Manifold Assembly

The **Low Profile Manifold Assembly (LPM)** is available in 3 different configurations to suit the cylinder family that it is to be paired with (see " **Low Profile Manifold Assembly Configurations**" table below). Each configuration includes the proper cylinder-seal O-ring to match the relevant cylinder mounting port, and a **High Pressure Relief Device (HPRD)** of the correct rating for the cylinder. Contact **Mountain High Equipment & Supply (MH)** for help in selecting the proper configuration for your needs.

Notes and Cautions:

- **Do not** use a cylinder with an incorrect **HPRD**, or **without** an **HPRD** (by sealing/plugging the **HPRD** port) - **severe damage, serious injury or death** could result!
- If the cylinder used with an existing **LPM** is being exchanged, the cylinder-seal O-ring should be replaced
- If the cylinder is being replaced with a different one, the **HPRD** may also need to be replaced with another of the proper pressure rating for the new cylinder
- **Do not** attempt to re-use an **HPRD** - once an **HPRD** is removed, it **must** be replaced
- Replacement/spare parts are available from **MH** (see "**Assembly Configurations**" table)

The **LPM** includes 3 general-purpose J1926 SAE-4F radial ports that are occupied in the default configuration by a 1/8" tube compression fitting, a 3/16" tube compression fitting, and a plug. If ordered together with a cylinder, the **LPM** can be installed onto the cylinder by **MH**. Other configurations can also be supplied upon request - contact **MH** for more information.

LPM assemblies as received from **MH** have been leak-tested and all fittings have been installed with proper torque. The default fittings may be rearranged or exchanged for other SAE-4M fittings as needed, with the following cautions:

- Never work on a pressurized system
- Install fittings to the proper torque specification using proper tools and procedures
- Cleanliness is critical. Contaminants such as oil, unapproved lubricants or cleaning agents, or metal particles, pose an **extreme safety hazard** with the potential of fire or explosion.
- Tubing and Fittings obtained from **MH** have been cleaned for oxygen service and should not need to be re-cleaned so long as proper hygiene has been maintained. Tubing and Fittings obtained elsewhere (even if the same part) may therefore not be suitable for use in oxygen systems unless it is known for certain that they have been properly cleaned.

REV	ECO	Release	Drawn	REVISION HISTORY
C1	2017-023	2017-07-17	SGO	Customer Drawing

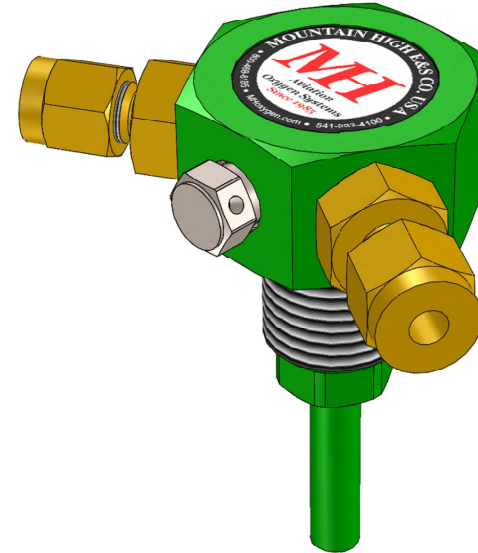

GENERAL SPECIFICATIONS

Material:	UNS A96061 (6061-T6) Aluminum (LPM Body) UNS C36000 (CDA-360) Brass (Fittings)
Weight:	4.4 oz [124 g] (default configuration)
Ports:	(see Sheet 2)
Pressure Rating:	4500 PSI Test
Temp Range:	-65°F to +160°F [-54°C to +71°C]
Pressure Relief:	(per Assembly Configurations Table)
Clean:	For Oxygen Service per MH ESR-008

Low Profile Manifold Assembly Configurations

LPM Assembly MH p/n	MH Cylinder Application	Cylinder Service Pressure	Cylinder O-ring MH p/n	HPRD MH p/n
00MAN-0022-00	CFF-480	3000	09001-3908-70	00VEN-0014-00
00MAN-0024-00	AL, CFFC	2015	09001-0210-90	00VEN-0015-00
00MAN-0026-00	KF	1800	09001-3908-70	00VEN-0011-00

High Pressure Relief Device Characteristics

HPRD MH p/n	MH Cylinder Application	Cylinder Service Pressure	Disc Rupture Range PSIG @ 160° F MIN-MAX	Rupture Disc Marking
00VEN-0011-00	KF	1800	2700-3000	3000
00VEN-0014-00	CFF-480	3000	4500-5000	5000
00VEN-0015-00	AL, CFFC	2015	3025-3360	3360

UNLESS OTHERWISE SPECIFIED, DIMENSIONS ARE IN INCHES. TOLERANCES ARE:

0.X ±0.015
0.XX ±0.010
0.XXX ±0.005

ANGLES ± 3°
FRACTIONS ± 1/64

INTERPRET GD&T PER ASME 14.5

THIRD ANGLE PROJECTION
DRAWN SGO
20174-07-10

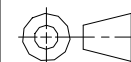

DO NOT SCALE DRAWING



MOUNTAIN HIGH E&S CO.
REDMOND, OR. USA

THIS DOCUMENT AND ALL TECHNICAL DATA HEREON DISCLOSED ARE PROPERTY OF MOUNTAIN HIGH E&S CO. AND SHALL NOT BE USED, RELEASED OR DISCLOSED IN WHOLE OR PART WITHOUT WRITTEN PERMISSION FROM MOUNTAIN HIGH E&S CO. THIS DOCUMENT MUST BE RETURNED TO MOUNTAIN HIGH E&S CO. IMMEDIATELY UPON REQUEST.

Customer Drawing,
Low Profile Manifold Assembly [SCD]

DWG TITLE	Customer Drawing, Low Profile Manifold Assembly [SCD]			DWG REV.	C1
DWG NUMBER	5SMAN-002x-00			DWG SIZE	A 11x8½
CAD FILE	00MAN-002x-00\$C1	INV. PART NUMBER	00MAN-0022-00 00MAN-0024-00 00MAN-0026-00	PROD. NAME	LPM-75-CFF LPM-75-CFFC LPM-75-KF
DWG FORMAT:	ESR-002 Rev H [20]	DWG SCALE		DWG SHEET	1 OF 2

1

2

3

Insert #: 5IMAN-002x-00

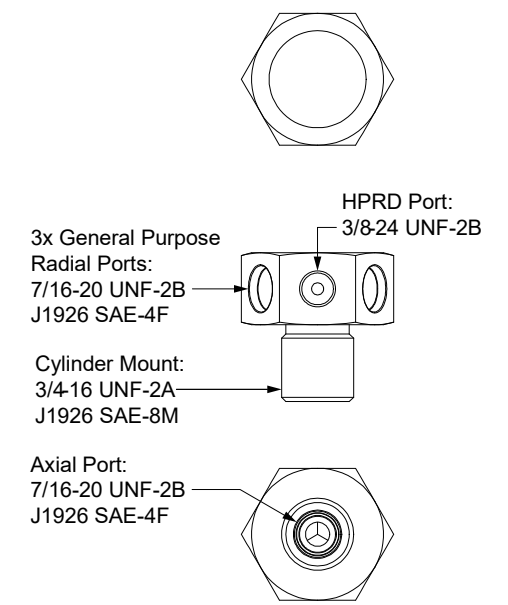
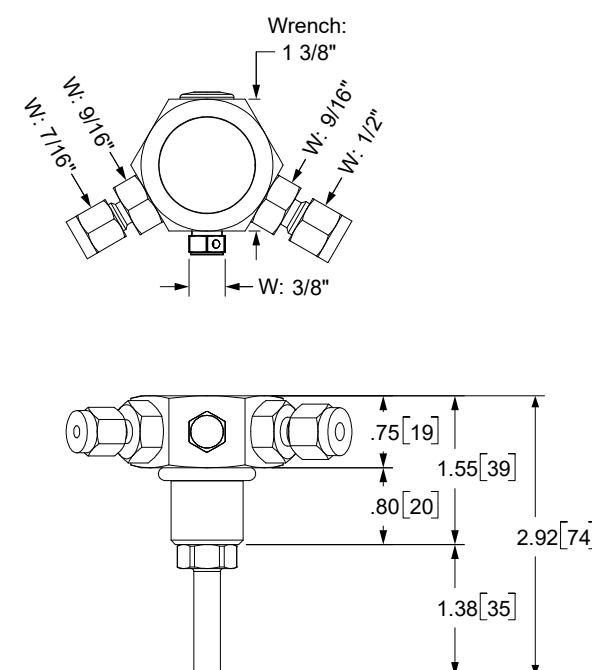
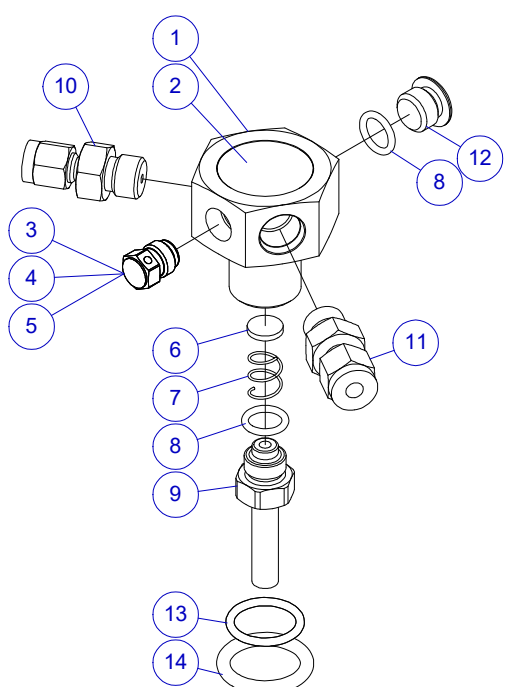

Torque Specifications	
SAE-4M Fittings	60 in-lbs [678 N-cm]
HPRD	60 in-lbs [678 N-cm]
SAE-8M (Cylinder)	60 FT-lbs [81 N-m]

Note: IN-lbs vs. FT-lbs

Item	0022	0024	0026	Part Number	Description
1	1	1	1	00MAN-0020-00	Low Profile Manifold
2	1	1	1	5RGX0-0001-00	Label
3	1			00VEN-0014-00	Burst Plug, 3000 psi service (CFF)
4		1		00VEN-0015-00	Burst Plug, 2015 psi service (AL/CFFC)
5			1	00VEN-0011-00	Burst Plug, 1850 psi service (KF)
6	1	1	1	09025-0001-00	Filter Disc
7	1	1	1	09010-0005-00	Spring
8	2	2	2	09001-3904-70	O-ring, SAE-4
9	1	1	1	00IPR-0208-00	Diptube
10	1	1	1	00HDW-0108-00	SAE-4M x 1/8" Tube Adapter, Brass
11	1	1	1	00HDW-0110-00	SAE-4M x 3/16" Tube Adapter, Brass
12	1	1	1	19035-0004-00	SAE-4M Port Plug
13	1		1	09001-3908-70	O-ring, SAE-8 (KF/CFF)
14		1		09001-0210-90	O-ring (AL/CFFC)

Refer to the following **MH** documents for information on Copper Tubing, Fittings and Adapters:

- 5SHDW-0100-00 (High Pressure Copper Tubing and Compression Tube Fittings)
- 5SHDW-0500-00 (High Pressure Adapter Fittings)

UNLESS OTHERWISE SPECIFIED, DIMENSIONS ARE IN INCHES. TOLERANCES ARE:
 0.X ±0.015
 0.XX ±0.010
 0.XXX ±0.005

ANGLES ± 3°
 FRACTIONS ± 1/64

INTERPRET GD&T PER ASME 14.5

63

MH MOUNTAIN HIGH E&S CO. REDMOND, OR. USA

THIS DOCUMENT AND ALL TECHNICAL DATA HEREON DISCLOSED ARE PROPERTY OF MOUNTAIN HIGH E&S CO. AND SHALL NOT BE USED, RELEASED OR DISCLOSED IN WHOLE OR PART WITHOUT WRITTEN PERMISSION FROM MOUNTAIN HIGH E&S CO. THIS DOCUMENT MUST BE RETURNED TO MOUNTAIN HIGH E&S CO. IMMEDIATELY UPON REQUEST.

Customer Drawing,
Low Profile Manifold Assembly [SCD]

DWG TITLE: **5SMAN-002x-00**

DWG NUMBER: **C1**

CAD FILE: 00MAN-002x-00\$C1

INV. PART NUMBER: 00MAN-0022-00, 00MAN-0024-00, 00MAN-0026-00

PROD. NAME: LPM-75-CFF, LPM-75-CFFC, LPM-75-KF

DWG FORMAT: ESR-002 Rev H [20]

DWG SCALE: 2 OF 2

DWG SHEET: 2 OF 2

DWG SIZE: A 11x8½

DO NOT SCALE DRAWING