

REVISION HISTORY				
REV	MO-DA-YR	NEO / ECO	APPROVED	NOTES
A	11-24-00	PLM	PLM	CORRECTED HOLE SPACING & DIA.
B	07-07-07	PLM	PLM	UPGRADED DRAWING TO REFLECT CURRENT VERSION OF GAUGE
C	10-06-11	PLM	PLM	SIMPLIFIED REAR-VIEW DETAIL

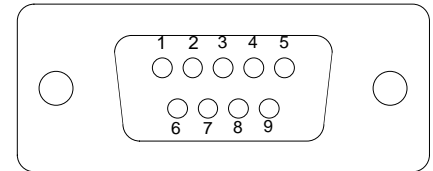

- 1: +12 TO +32 VDC POWER INPUT
- 2: INTERNALLY CONNECTED TO PIN 1
- 3: +12 VDC OUT FOR 14V SENDING UNITS ONLY
- 4: N/C
- 5: INPUT (4 - 20 MA PRESSURE SENDING UNIT)
- 6: EL INTERNAL LIGHTING AC INPUT
- 7: EL INTERNAL LIGHTING AC INPUT
- 8: INTERNALLY CONNECTED TO PIN 9
- 9: GROUND

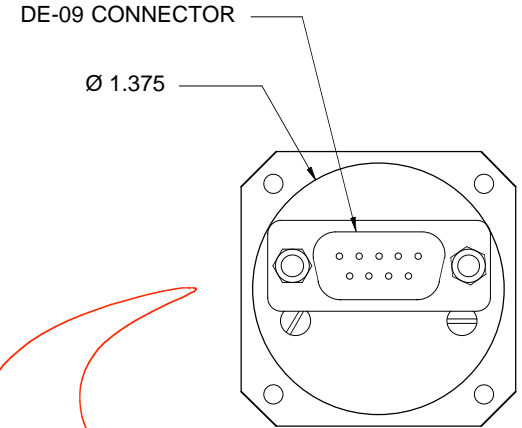
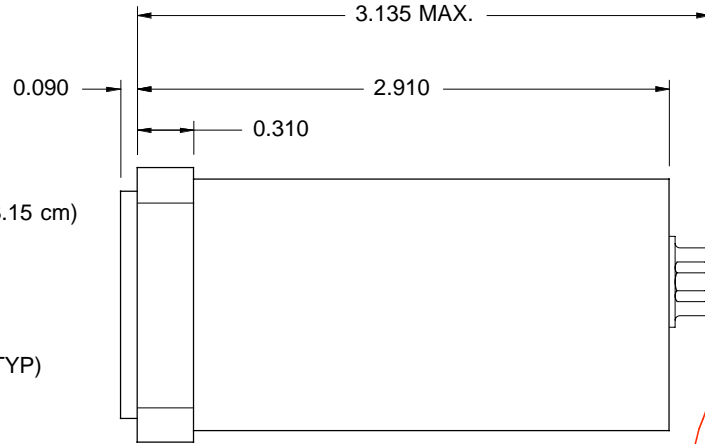
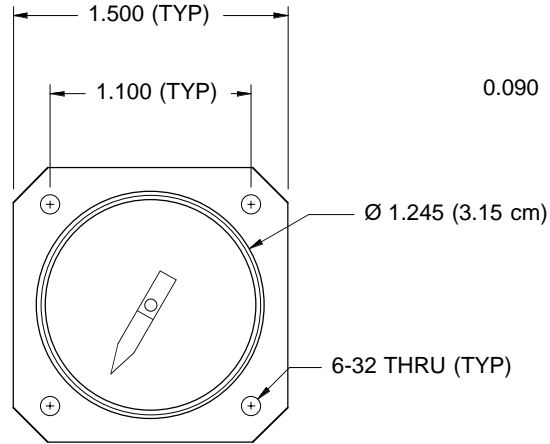
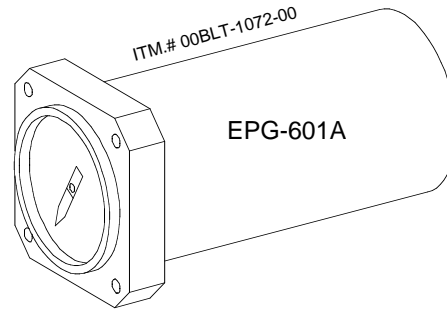
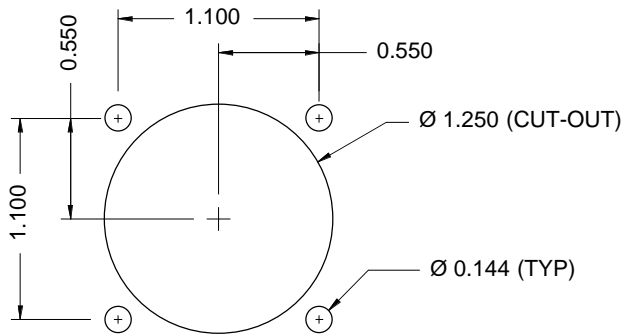

MODEL EPG-601A
ITM.# 00BLT-1072-00

UNLESS OTHERWISE SPECIFIED DIMS ARE IN INCHES. TOLERANCES ARE:				 THIRD ANGLE PROJECTION DO NOT SCALE DRAWING	 MOUNTAIN HIGH E&S CO. REDMOND, OR. USA
0.X	±0.015	ANGLES	FRACTIONS		
0.XX	±0.010	± 0.5°	± 1/64		
0.XXX	±0.005				
INTERPRET GD&T PER ASME 14.5				FMT REV G	[KC] 00
ORIG.:	PLM	11-10-00	OXYGEN E-GAUGE, 1.5" FORM-FACTOR (SCD)		
DRWN.:	PLM	11-10-00	DWG. # 0EPG6-051-001	REV C	SIZE A
ENG.:	PLM	11-10-00	MOD.# EPG-601A	ITM.# 00BLT-1072-00	
APPR.:	NAME	MO-DA-YR	SHEET 1 OF 1		CUSTOMER CODE