



Company: Product Management Office, Air Warrior
Model Tested: OPC-M2
Report Number: 28380
Project Number: 13049

1250 PETERSON DRIVE, WHEELING, IL 60090-6454 • PHONE 847-537-6400 • FAX 847-537-6488 • www.dlsemc.com

TEST REPORT

MILITARY STANDARD
MIL-STD-461G (11 December 2015)
REQUIREMENTS FOR THE CONTROL OF ELECTROMAGNETIC INTERFERENCE
CHARACTERISTICS OF SUBSYSTEMS AND EQUIPMENT

ACCORDING TO

OPC-M2 EMI SOF TEST PLAN REV B 1.19.24 WITH REDLINES

SUMMARY OF TEST RESULTS CAN BE FOUND IN SECTION 10.0 OF THIS REPORT

Equipment Under Test: Oxygen pulse controller
Test Voltage: Battery Operated
Model Number: OPC-M2
Model Tested: OPC-M2
Serial Number: 05694
Dates of Test: February 23, 27, 28 & 29 and March 1 & 4, 2024
Test Conducted for: Product Management Office, Air Warrior
6726 Odyssey Drive
Huntsville, AL 35806
Date of Report: July 15, 2024
Revision Level: A

NOTICE: "This test report contains test data, equipment lists, photographs and/or other information regarding only the sample provided by the client for testing."

© Copyright 1983-2024 D.L.S. Electronic Systems, Inc.

COPYRIGHT NOTICE

This report must not be reproduced (except in full), without the approval of D.L.S. Electronic Systems, Inc.



SIGNATURE PAGE

Report Written By:

A handwritten signature in black ink that reads "Marc C. Hess".

Marc Hess
Technical Writer

Report Reviewed By:

A handwritten signature in black ink that reads "Mark Rozema".

Mark Rozema
Wheeling Lab Manager

Report Approved By:

A handwritten signature in black ink that reads "Brian J. Mattson".

Brian J. Mattson
General Manager



Company: Product Management Office, Air Warrior
Model Tested: OPC-M2
Report Number: 28380
Project Number: 13049

TABLE OF CONTENTS

i.	Cover Page	1
ii.	Signature Page	2
iii.	Table of Contents	3
iv.	ANAB Certificate of Accreditation	4
1.0	Introduction	5
2.0	Test Facility	5
3.0	Lab Descriptions.....	5
4.0	Test Equipment.....	5
5.0	References	6
6.0	Test Set-Up.....	6
7.0	Performance Monitored.....	6
8.0	Description of Test Sample	7
9.0	Modifications Made to the EUT for EMC Compliance	7
10.0	Summary of Test Results.....	7
11.0	Photo Information and Test Setup.....	7
11.1	Photo ID Taken During Testing	8
RE102,	Electric Field Emissions	9
1.0	Test Dates	10
2.0	Equipment Under Test.....	10
3.0	Test Specifications	10
4.0	Limits.....	11
5.0	Results	12
Table 1	- Test Instrumentation	13
Table 2	- Test Equipment	14
6.0	Test Setup Photos	15
7.0	Test Data.....	31
8.0	Continuity Check Data	46
9.0	Verification Data	55
10.0	Ambient Data	64
RS103,	Electric Field Susceptibility.....	79
1.0	Test Dates	80
2.0	Equipment Under Test.....	80
3.0	Test Specifications	80
4.0	Limits.....	80
5.0	Results	81
Table 1	- Test Instrumentation	82
Table 2	- Test Equipment	83
6.0	Test Setup Photos	84
7.0	Test Data.....	98
8.0	Plots Data	114
Appendix A:	QTP Redlines	130



Company: Product Management Office, Air Warrior
 Model Tested: OPC-M2
 Report Number: 28380
 Project Number: 13049



CERTIFICATE OF ACCREDITATION

The ANSI National Accreditation Board

Hereby attests that

DLS Electronic Systems, Inc.
 1250 Peterson Drive
 Wheeling, IL 60090
 (and satellite locations as shown on the scope)

Fulfills the requirements of

ISO/IEC 17025:2017

and

U.S. Federal Communication Commission (FCC) EMC and Telecommunications (EC&T) Testing Designation Program

and

Recognition of Telecommunications Testing - Innovation, Science, and Economic Development (ISED) Canada

and

FDA Accreditation Scheme for Conformity Assessment (ASCA) Pilot Program -Basic Safety and Essential Performance of Medical Electrical Equipment, Medical Electrical Systems, and Laboratory Medical Equipment

In the field of

TESTING

This certificate is valid only when accompanied by a current scope of accreditation document.
 The current scope of accreditation can be verified at www.anab.org

Jason Stine, Vice President
 Expiry Date: 23 April 2024
 Certificate Number: AT-1859



This laboratory is accredited in accordance with the recognized International Standard ISO/IEC 17025:2017. This accreditation demonstrates technical competence for a defined scope and the operation of a laboratory quality management system (refer to joint ISO-ILAC-IAF Communiqué dated April 2017).



Company: Product Management Office, Air Warrior
Model Tested: OPC-M2
Report Number: 28380
Project Number: 13049

1.0 INTRODUCTION

On February 23, 27, 28 & 29 and March 1 & 4, 2024, a series of tests were performed on the Oxygen pulse controller, Model OPC-M2, Serial Number 05694, using the requirements of MIL-STD-461G, Requirements for the Control of Electromagnetic Interference Characteristics of Subsystems and Equipment, per OPC-M2 EMI SOF Test Plan Rev B 1.19.24 with Redlines, and using the following tests:

- RE102, Electric Field Emissions
- RS103, Electric Field Susceptibility

2.0 TEST FACILITY

D.L.S. Electronic Systems, Inc. is a full service EMC Testing Laboratory accredited to ISO Guide 17025. Our ANAB Certificate and Scope of Accreditation can be viewed at dlsemc.com/accreditations. Our facilities are registered with the FCC, ISED, and VCCI. All immunity tests were performed by personnel of D.L.S. Electronic Systems, Inc., 1250 Peterson Drive, Wheeling, Illinois 60090.

3.0 LAB DESCRIPTIONS

The following describes the various labs that were used for testing:

RE102, Electric Field Emissions:

LAB C: 26' long x 16' wide x 16' high semi-ferrite lined enclosure.

RS103, Electric Field Susceptibility:

LAB R: 35' long x 21' wide x 20' high anechoic/ferrite tile lined enclosure.

4.0 TEST EQUIPMENT

A list of the test equipment used, along with identification and calibration data, is included in the Table of each test procedure section of this report. All primary equipment was calibrated against known reference standards with a verified traceable path to NIST.



Company: Product Management Office, Air Warrior
Model Tested: OPC-M2
Report Number: 28380
Project Number: 13049

5.0 REFERENCES

MIL-STD-461G Requirements for the Control of Electromagnetic Interference Emission and Susceptibility Characteristics of Subsystems and Equipment (11 December 2015)

DoDI6055.11 - Protection of DoD Personnel from Exposure to Radio Frequency Radiation and Military Exempt Lasers

SD-2 - Buying Commercial and Non-developmental Items

OPC-M2 EMI SOF Test Plan Rev B 1.19.24 with Redlines
Oxygen Pulse Controller OPC-M2 Electromagnetic Interference Safety Of Flight Qualification Test Plan

6.0 TEST SET-UP

The Oxygen pulse controller was placed on a non-conductive table and floor. Placement of the antennas was made so that no part of the elements would be closer than 1 meter from chamber walls.

All test measurements were made at a laboratory temperature of 71°F at 37% humidity

Please see each test for specific mode of operation.

7.0 PERFORMANCE MONITORED

The Oxygen pulse controller performance was monitored as follows:

Oxygen pulses approximately every 5 seconds was monitored for consistency.



8.0 DESCRIPTION OF TEST SAMPLE

8.1 DESCRIPTION

The sample is a wearable oxygen delivery system for aviation applications. The device receives oxygen from a small tank and provides it to the wearer in small bursts as needed.

8.2 PHYSICAL DIMENSIONS OF EQUIPMENT UNDER TEST

Length: 5.23" in x Width: 3.1" in x Height: 0.95" in

9.0 MODIFICATIONS MADE TO THE EUT FOR EMC COMPLIANCE

There were no changes made during testing.

10.0 SUMMARY OF TEST RESULTS

The Oxygen pulse controller, Model OPC-M2, was subjected to the requirements of MIL-STD-461G, Requirements for the Control of Electromagnetic Interference Characteristics of Subsystems and Equipment, per OPC-M2 EMI SOF Test Plan Rev B 1.19.24 with Redlines, with the results as described in the below table. Problems at 200V/M mainly in the 200-1000MHz frequency range in the Vertical position.

Test Section	Result
RE102, Electric Field Emissions	Meets
RS103, Electric Field Susceptibility	Was Tested To

See the following test sections and Appendix A for a detailed explanation of the test results.

11.0 PHOTO INFORMATION AND TEST SETUP

The test set up can be seen in the accompanying photograph.

Item 0 EUT



Company: Product Management Office, Air Warrior
Model Tested: OPC-M2
Report Number: 28380
Project Number: 13049

11.1 PHOTO ID TAKEN DURING TESTING

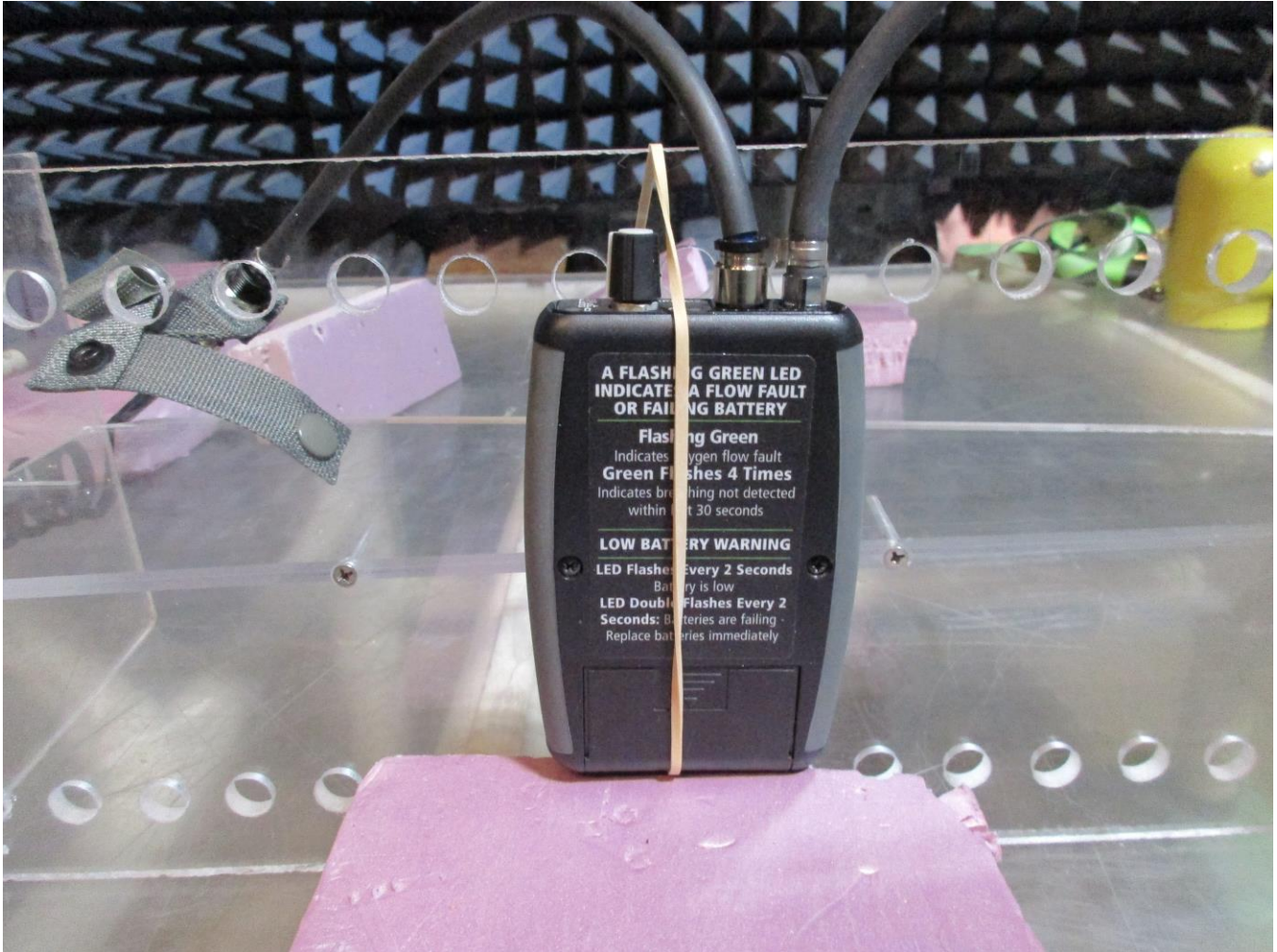

Photo ID



Company: Product Management Office, Air Warrior
Model Tested: OPC-M2
Report Number: 28380
Project Number: 13049
Test: RE102, Electric Field Emissions

MIL-STD-461G

RE102

RADIATED EMISSIONS

ELECTRIC FIELD

USING

OPC-M2 EMI SOF TEST PLAN REV B 1.19.24 WITH REDLINES



Company: Product Management Office, Air Warrior
Model Tested: OPC-M2
Report Number: 28380
Project Number: 13049
Test: RE102, Electric Field Emissions

1.0 TEST DATES

February 23-27, 2024

2.0 EQUIPMENT UNDER TEST

Description: Oxygen pulse controller
Quantity: One (1)
Model Tested: OPC-M2
Serial Number: 05694

3.0 TEST SPECIFICATIONS

The Oxygen pulse controller was subjected to Electric Field Emissions, over the frequency range from 10 kHz - 18 GHz, and also the general requirements of MIL-STD-461G RE102, per OPC-M2 EMI SOF Test Plan Rev B 1.19.24 with Redlines.

There shall be no physical or electrical failures that prevent the EUT from being operated per customer's test requirements; the EUT shall meet inspection requirements of customer QTP.



Company: Product Management Office, Air Warrior
 Model Tested: OPC-M2
 Report Number: 28380
 Project Number: 13049
 Test: RE102, Electric Field Emissions

4.0 LIMITS

The Oxygen pulse controller was tested to the following requirements of MIL-STD-461G RE102 Electric Field Emissions, per OPC-M2 EMI SOF Test Plan Rev B 1.19.24 with Redlines as shown below:

TABLE II. Bandwidth and measurement time.

Frequency Range	6 dB Resolution Bandwidth	Minimum Dwell Time - Stepped-Tuned Receiver 1/ (Seconds)	Minimum Dwell Time - FFT Receiver 2/(Seconds/ Measurement Bandwidth)	Minimum Measurement Time Analog-Tuned Measurement Receiver 1/
10 kHz - 150 kHz	1 kHz	0.015	1	0.015 sec/kHz
150 kHz - 10 MHz	10 kHz	0.015	1	1.5 sec/MHz
10 MHz - 30 MHz	10 kHz	0.015	0.15	1.5 sec/MHz
30 MHz - 1 GHz	100 kHz	0.015	0.15	0.15 sec/MHz
above 1 GHz	1 MHz	0.015	0.015	15 sec/GHz

1/ **Alternative scanning technique.** Multiple faster sweeps with the use of a maximum hold function may be used if the total scanning time is equal to or greater than the Minimum Measurement Time defined above.

2/ **FFT Receivers.** FFT measurement techniques may be used provided that FFT operation is in accordance with ANSI C63.2. The user interface of the measurement receiver must allow for the direct input of the parameters in Table II for both FFT Time Domain and Frequency Stepped modes of measurement in the same manner, without the necessity or opportunity to control FFT functions directly.



Company: Product Management Office, Air Warrior
Model Tested: OPC-M2
Report Number: 28380
Project Number: 13049
Test: RE102, Electric Field Emissions

5.0 RESULTS

The Oxygen pulse controller **meets** the following conditions of MIL-STD-461G RE102 Electric Field Emissions, per OPC-M2 EMI SOF Test Plan Rev B 1.19.24 with Redlines.

Lab used: C

Frequency Range: 10 kHz - 18 GHz

Mode of Operation:

normal operation

Levels:

The Fixed Wing External or Helicopter was tested in the frequency range 10 kHz - 18 GHz.

Summary:

No events were observed.

Plots and tabular data can be viewed at the end of this section.



Company: Product Management Office, Air Warrior
 Model Tested: OPC-M2
 Report Number: 28380
 Project Number: 13049
 Test: RE102, Electric Field Emissions

TEST INSTRUMENTATION

TABLE 1

Description	Manufacturer	Model Number	Serial Number	Range	Firmware/ Software Version	Cal On	Cal Due Dates
Antenna, Biconical	Electro-Metrics	BIA-25C	2617	20MHz-300MHz	N/A	7/27/2023	7/26/2024
Antenna, Horn	ETS-Lindgren	3115	9912-5995	1GHz-18GHz	N/A	6/3/2023	6/2/2024
Antenna, Horn, DRG	EMCO	3117	00256138	1-18GHz	N/A	12/7/2023	12/6/2024
Antenna, Rod, Active	ETS-Lindgren	3301C	00081111	30Hz-50MHz	N/A	11/8/2023	11/7/2024
Cable, BNC-BNC, RG223/U	Pasternack Enterprises	PE3087-120	10ft. SN015	10kHz-1GHz	N/A	9/13/2023	9/12/2024
Cable, BNC-BNC, RG223/U	Pasternack Enterprises	PE3087-300	25ft. SN053	10kHz-1GHz	N/A	11/20/2023	11/19/2024
Cable, BNC-BNC, RG223/U	Pasternack Enterprises	PE3087-300	25ft. SN018	10kHz-1GHz	N/A	8/4/2023	8/3/2024
Cable, BNC-BNC, RG223/U	Pasternack Enterprises	PE3087-36	3ft. SN034	10kHz-1GHz	N/A	1/22/2024	1/21/2025
Cable, BNC-BNC, RG223/U	Pasternack Enterprises	PE3087-72	6ft. SN032	10kHz-1GHz	N/A	2/9/2024	2/8/2025
Cable, N-N	Teledyne Storm Products	TSP-90-195-96 N-N	8ft. SN001	1GHz-18GHz	N/A	5/19/2023	5/18/2024
Cable, N-N	Teledyne Storm Products	TSP-90-195-108 N-N	9ft. SN002	1GHz-18GHz	N/A	10/26/2023	10/25/2024
Cable, N-N	Teledyne Storm Products	TSP-90-195-108 N-N	9ft. SN004	1GHz-18GHz	N/A	5/19/2023	5/18/2024
Generator, Signal	Rohde & Schwarz	SMY 01	844484/002	9kHz-1.04GHz	N/A	6/21/2023	6/20/2025
Generator, Signal	Rohde & Schwarz	SML03	103785	9kHz-3.3GHz	2.51.15:5/14/2008	1/17/2024	1/16/2025
Preamplifier, RF	Com-Power	PAM-118A	18040165	500MHz - 18GHz	N/A	3/14/2023	3/13/2024
Signal Generator	Rohde & Schwarz	SMB100A	178704	100 kHz to 40 GHz	3.01.203.51:2/26/2016	4/17/2023	4/16/2024
Spectrum Analyzer	Agilent Technologies	E4446A	MY46180377	3Hz-44GHz	A.09.19:2/2/2007	1/16/2024	1/15/2025

All primary equipment is calibrated against known reference standards with a verified traceable path to NIST.



Company: Product Management Office, Air Warrior
Model Tested: OPC-M2
Report Number: 28380
Project Number: 13049
Test: RE102, Electric Field Emissions

TEST EQUIPMENT

TABLE 2

Description	Manufacturer	Model Number	Serial Number	Range
Antenna, Horn	EMCO	3106	2127	200MHz-2GHz
MIL-STD 461G Verification Network	DLS Electronic Systems	N/A	N/A	10k-30MHz

The above test equipment is verified upon use.



Company: Product Management Office, Air Warrior
Model Tested: OPC-M2
Report Number: 28380
Project Number: 13049
Test: RE102, Electric Field Emissions

MIL-STD-461G

RE102

RADIATED EMISSIONS

ELECTRIC FIELD

USING

OPC-M2 EMI SOF TEST PLAN REV B 1.19.24 WITH REDLINES

TEST SETUP PHOTOS



Company: Product Management Office, Air Warrior
Model Tested: OPC-M2
Report Number: 28380
Project Number: 13049
Test: RE102, Electric Field Emissions

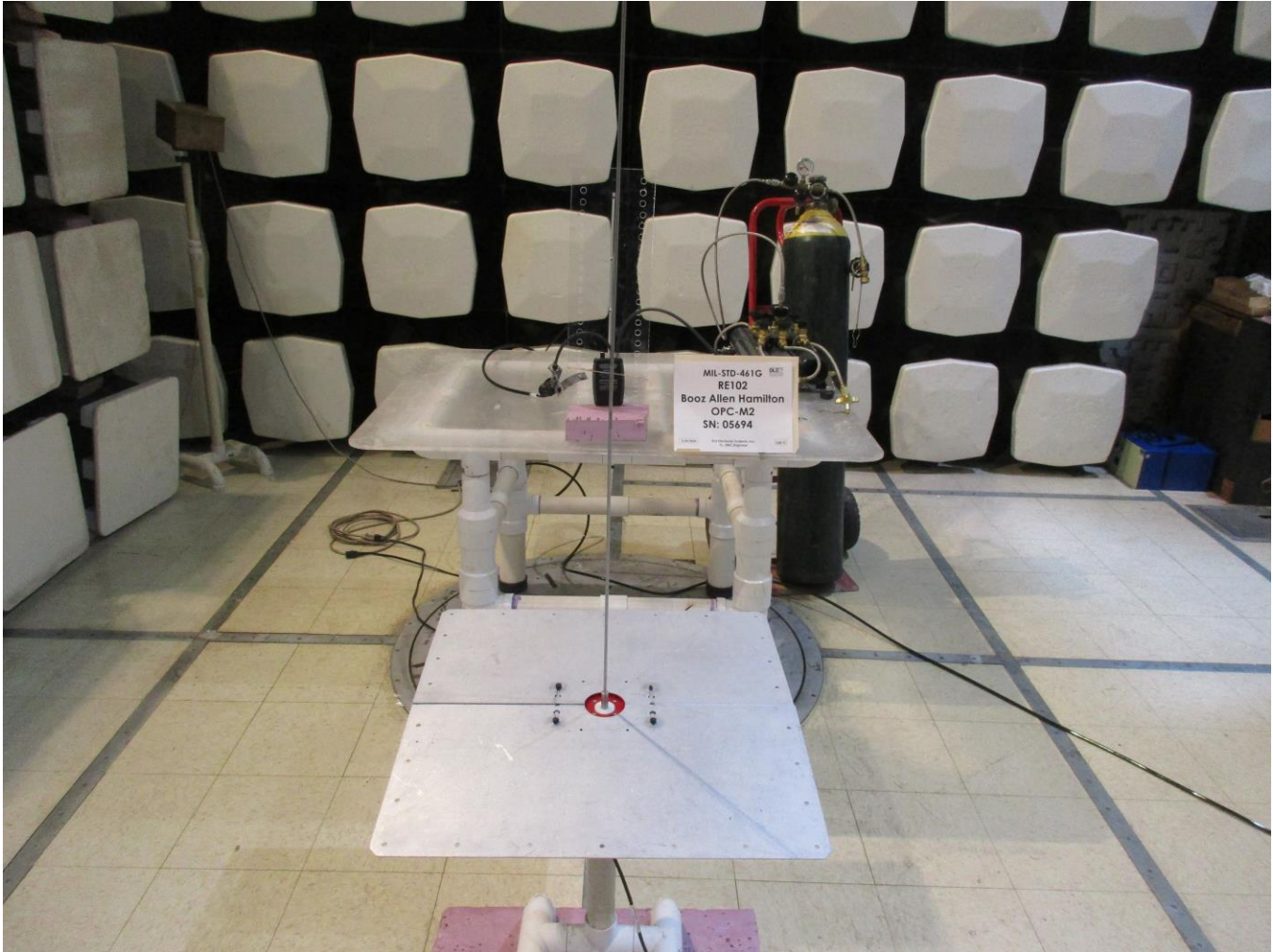

RE102 10kHz-30MHz Test



Company: Product Management Office, Air Warrior
Model Tested: OPC-M2
Report Number: 28380
Project Number: 13049
Test: RE102, Electric Field Emissions

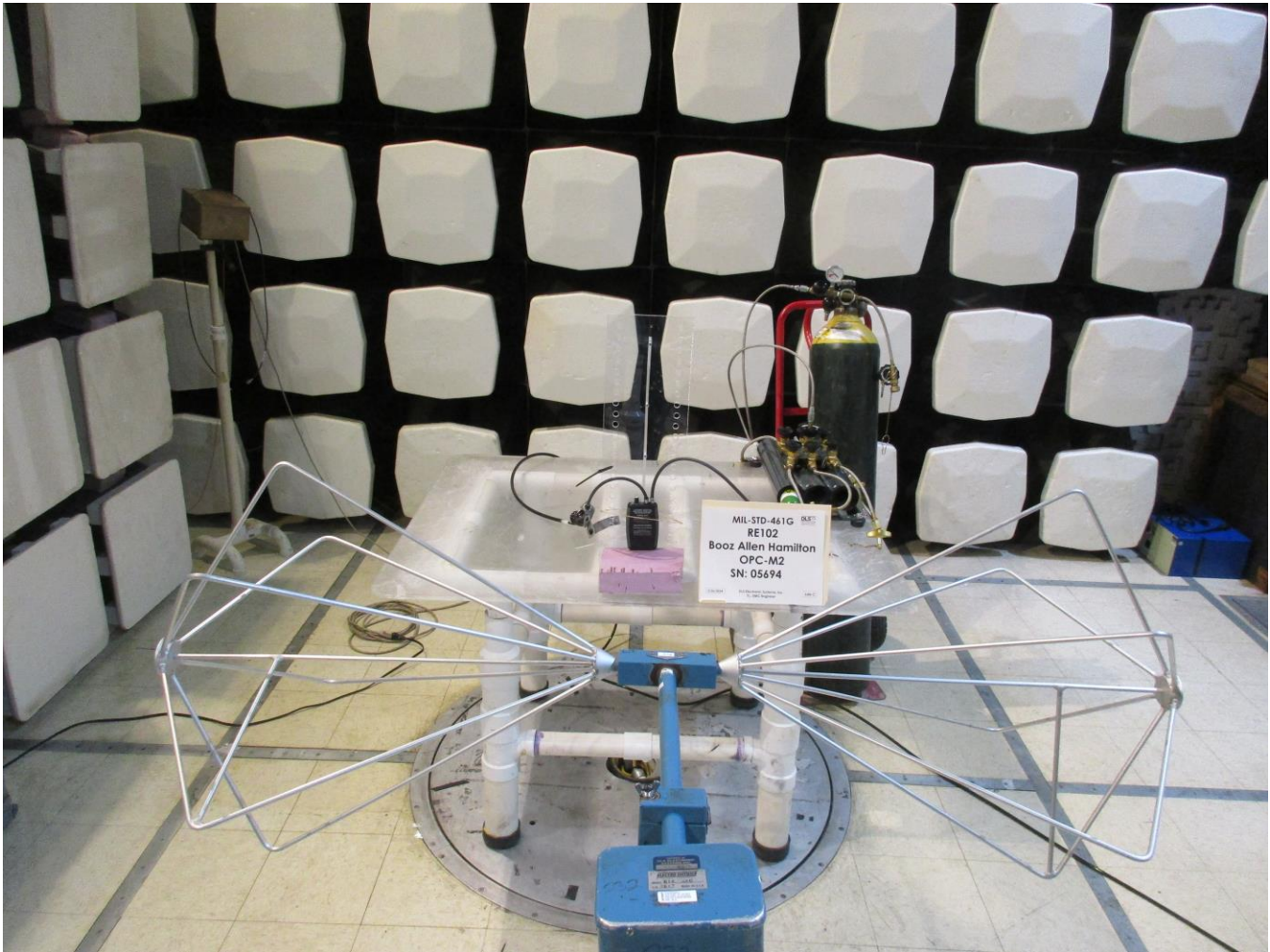

RE102 30-200MHz Horizontal Test



Company: Product Management Office, Air Warrior
Model Tested: OPC-M2
Report Number: 28380
Project Number: 13049
Test: RE102, Electric Field Emissions



RE102 30-200MHz Vertical Test



Company: Product Management Office, Air Warrior
Model Tested: OPC-M2
Report Number: 28380
Project Number: 13049
Test: RE102, Electric Field Emissions

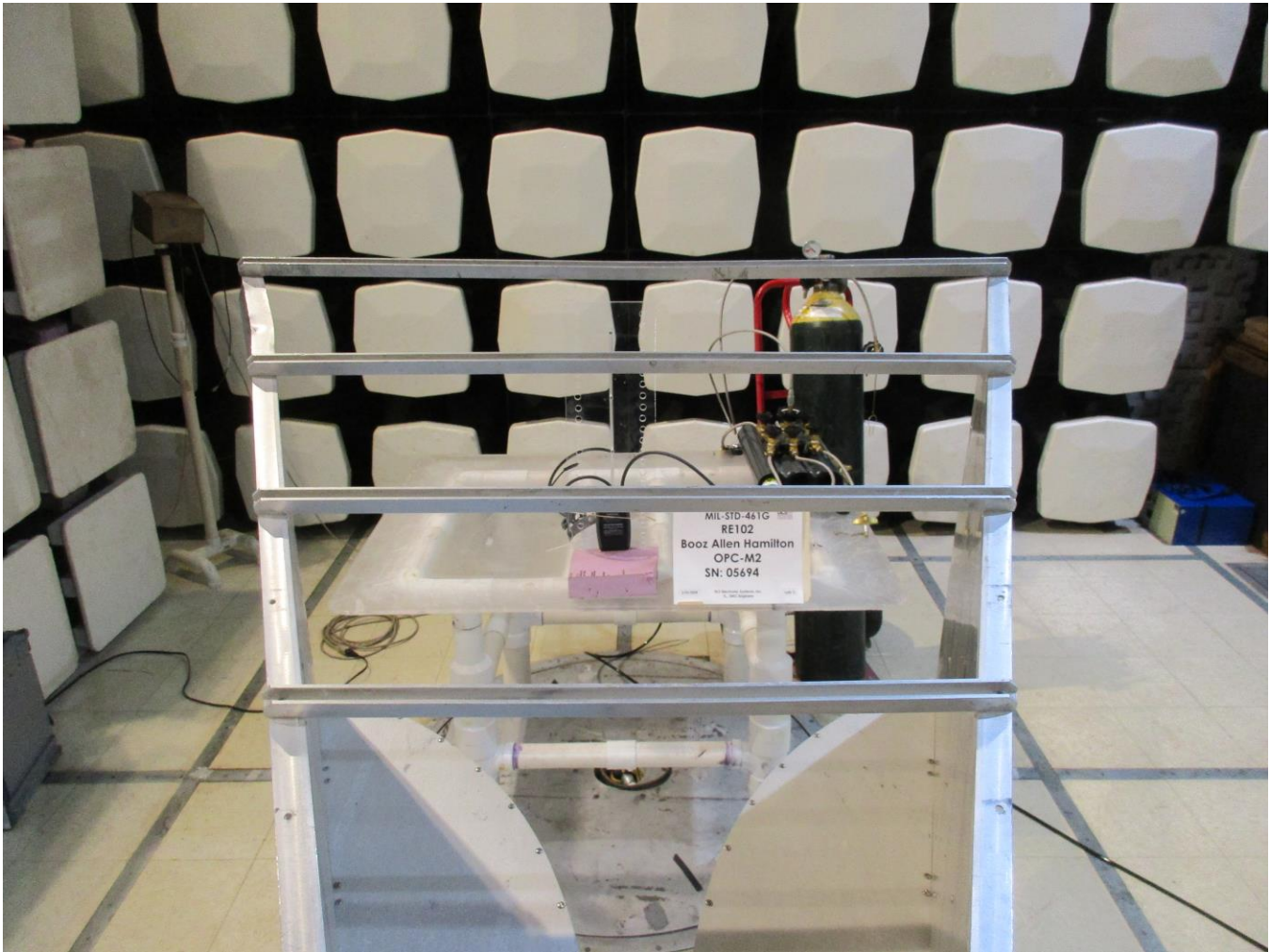

RE102 200-1000MHz Horizontal Test



Company: Product Management Office, Air Warrior
Model Tested: OPC-M2
Report Number: 28380
Project Number: 13049
Test: RE102, Electric Field Emissions

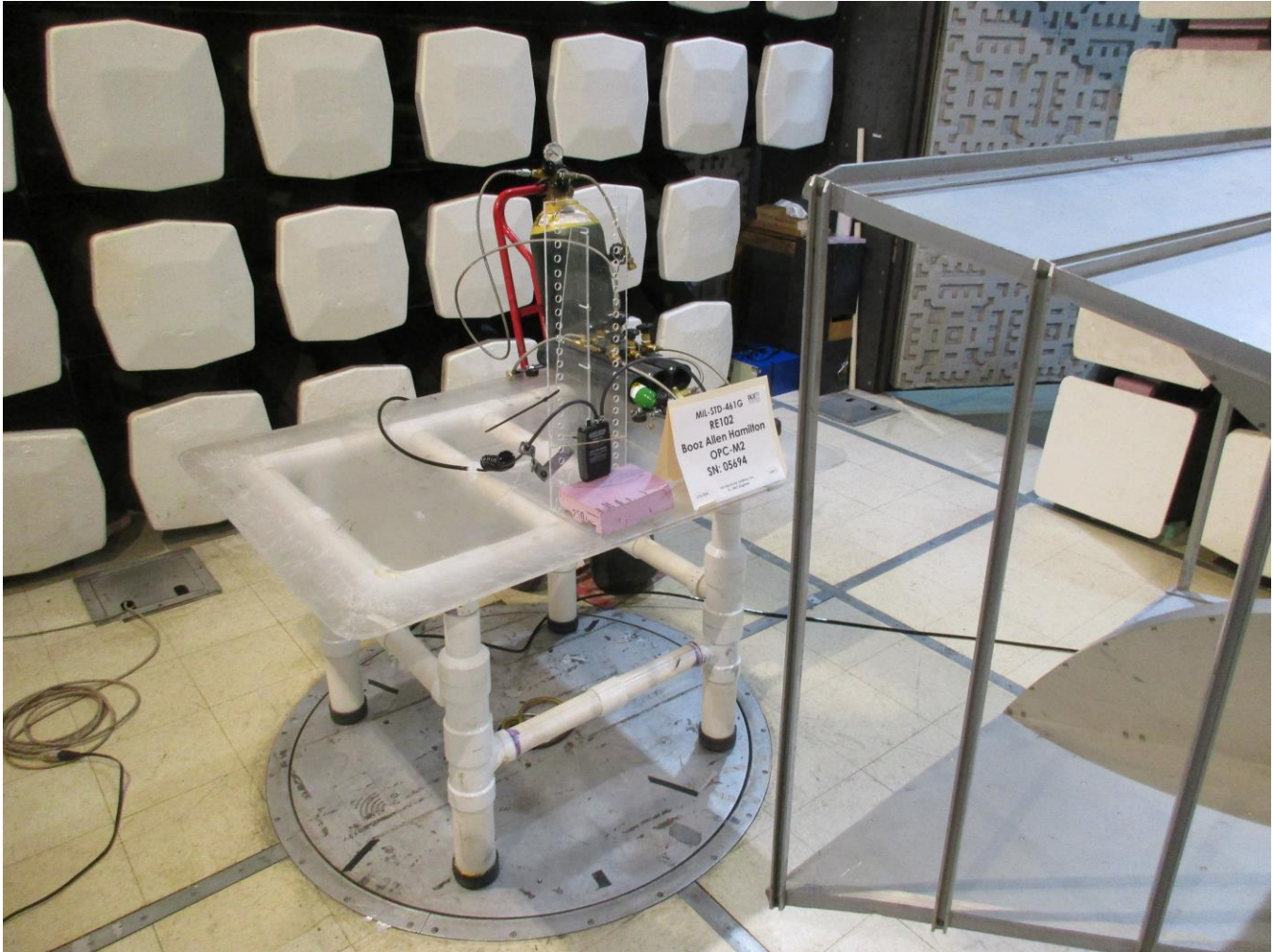

RE102 200-1000MHz Vertical Test (1 of 2)



Company: Product Management Office, Air Warrior
Model Tested: OPC-M2
Report Number: 28380
Project Number: 13049
Test: RE102, Electric Field Emissions

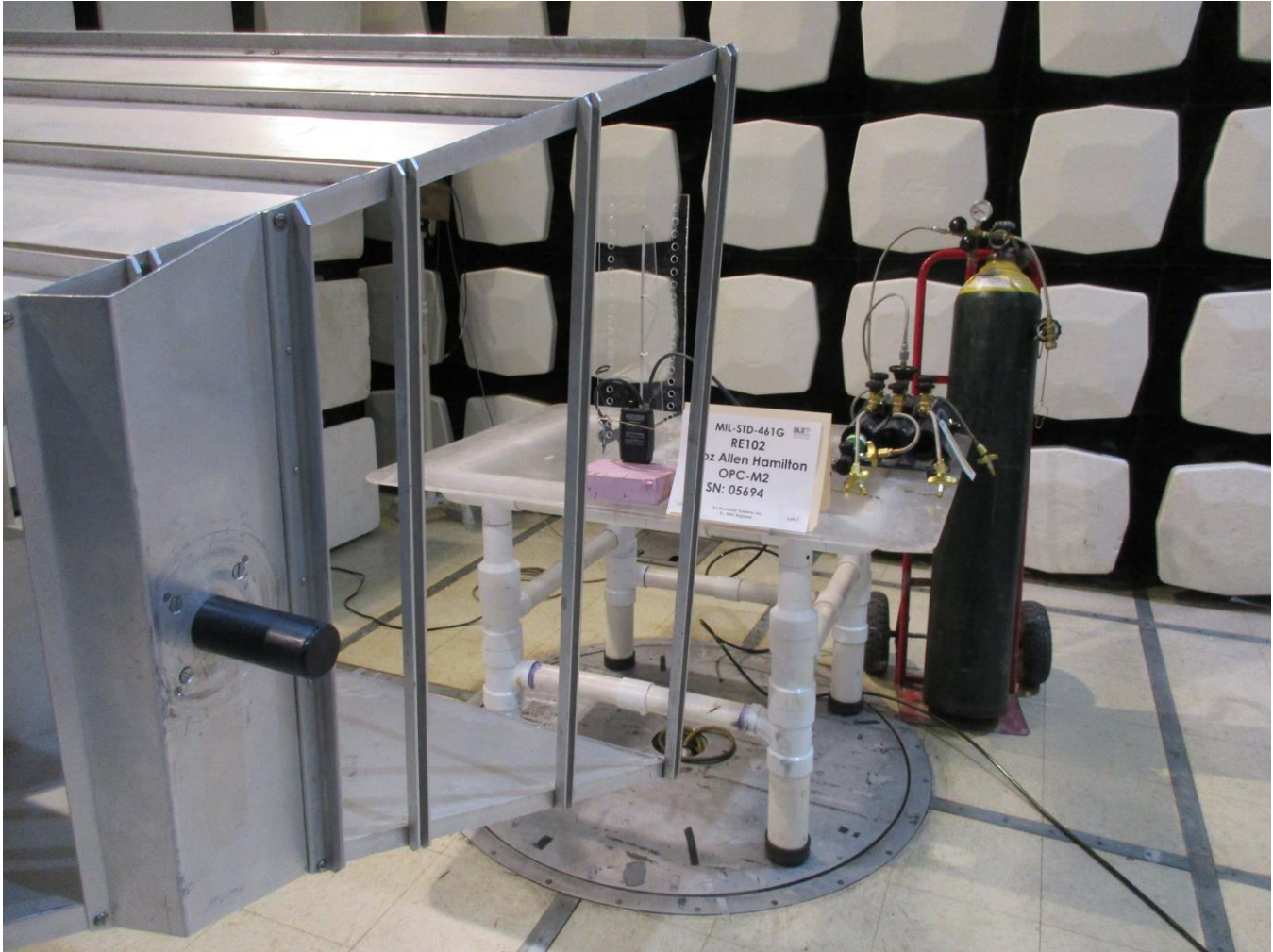

RE102 200-1000MHz Vertical Test (2 of 2)



Company: Product Management Office, Air Warrior
Model Tested: OPC-M2
Report Number: 28380
Project Number: 13049
Test: RE102, Electric Field Emissions

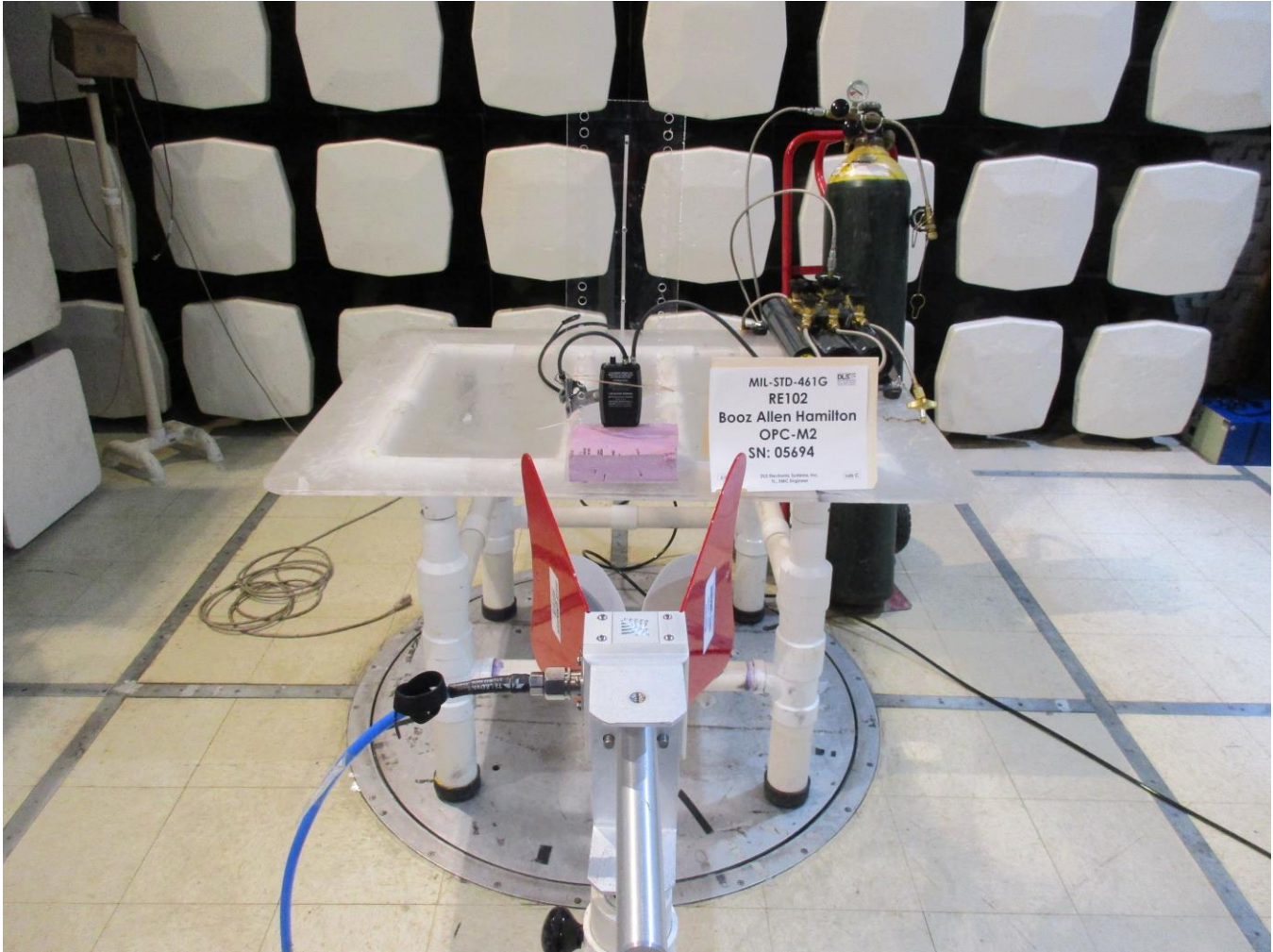

RE102 1-18GHz Horizontal Test



Company: Product Management Office, Air Warrior
Model Tested: OPC-M2
Report Number: 28380
Project Number: 13049
Test: RE102, Electric Field Emissions

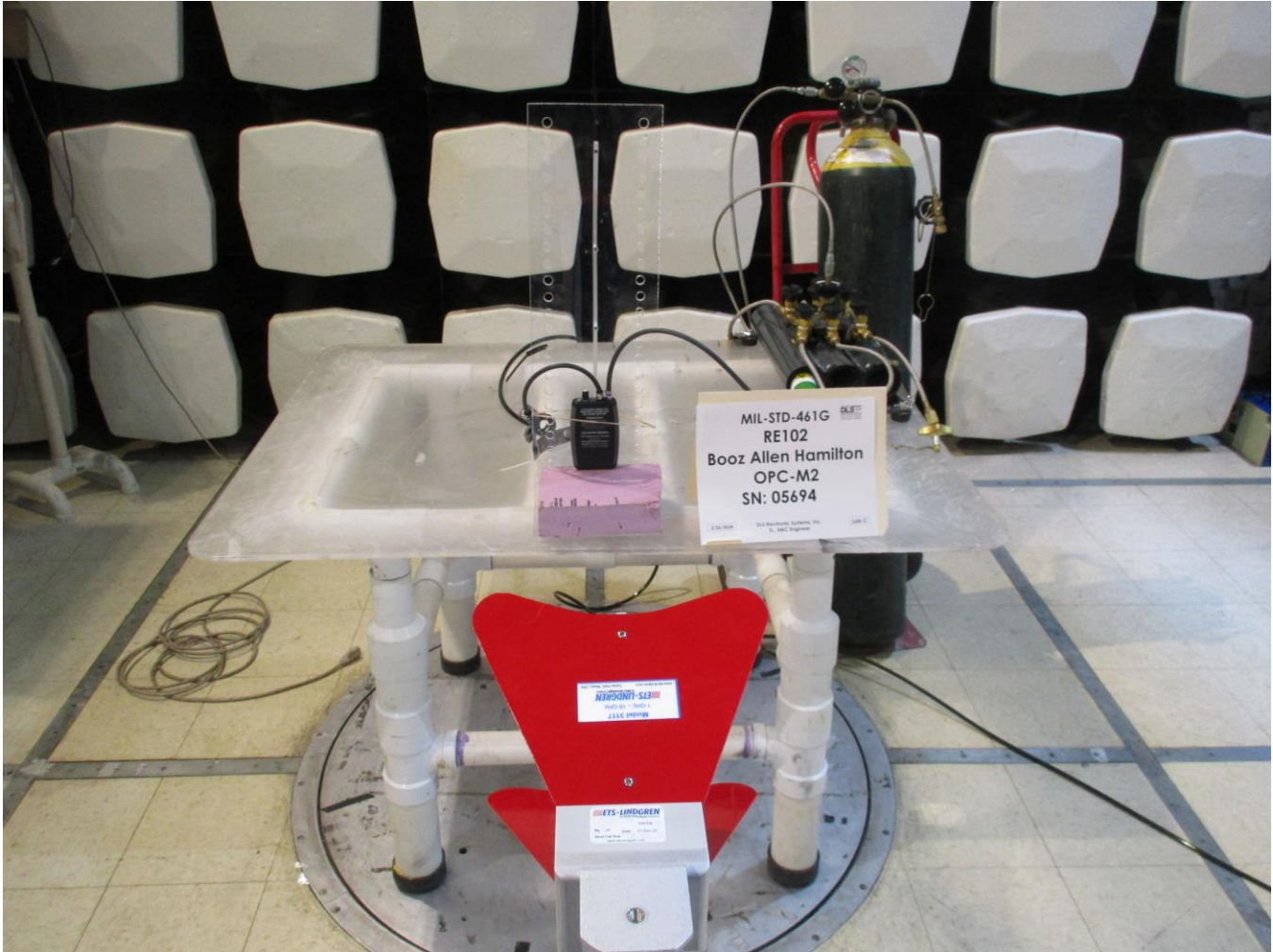

RE102 1-18GHz Vertical Test



Company: Product Management Office, Air Warrior
Model Tested: OPC-M2
Report Number: 28380
Project Number: 13049
Test: RE102, Electric Field Emissions

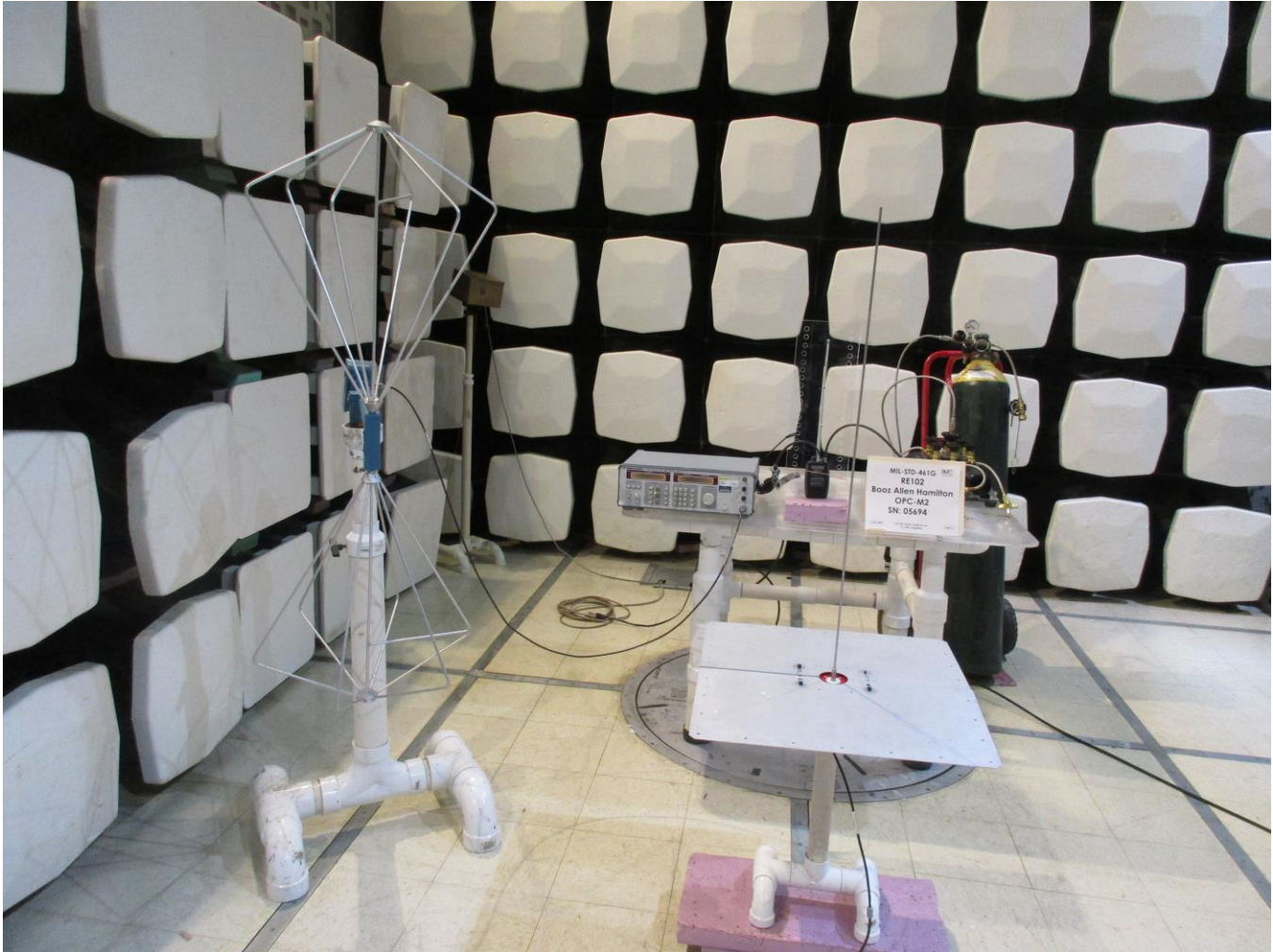

RE102 10kHz-30MHz Antenna Continuity



Company: Product Management Office, Air Warrior
Model Tested: OPC-M2
Report Number: 28380
Project Number: 13049
Test: RE102, Electric Field Emissions

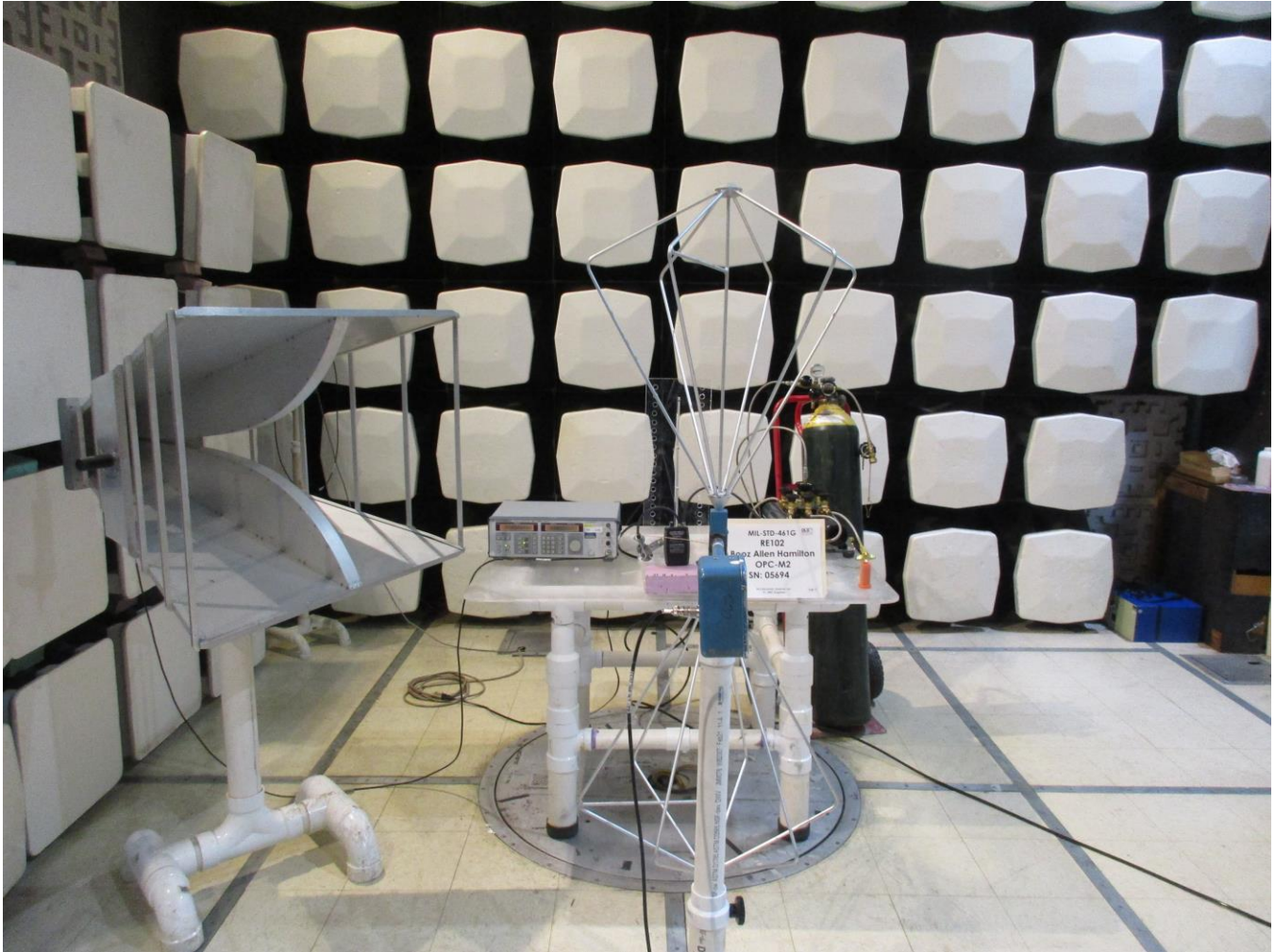

RE102 30-200MHz Antenna Continuity



Company: Product Management Office, Air Warrior
Model Tested: OPC-M2
Report Number: 28380
Project Number: 13049
Test: RE102, Electric Field Emissions



RE102 200-1000MHz Antenna Continuity



Company: Product Management Office, Air Warrior
Model Tested: OPC-M2
Report Number: 28380
Project Number: 13049
Test: RE102, Electric Field Emissions

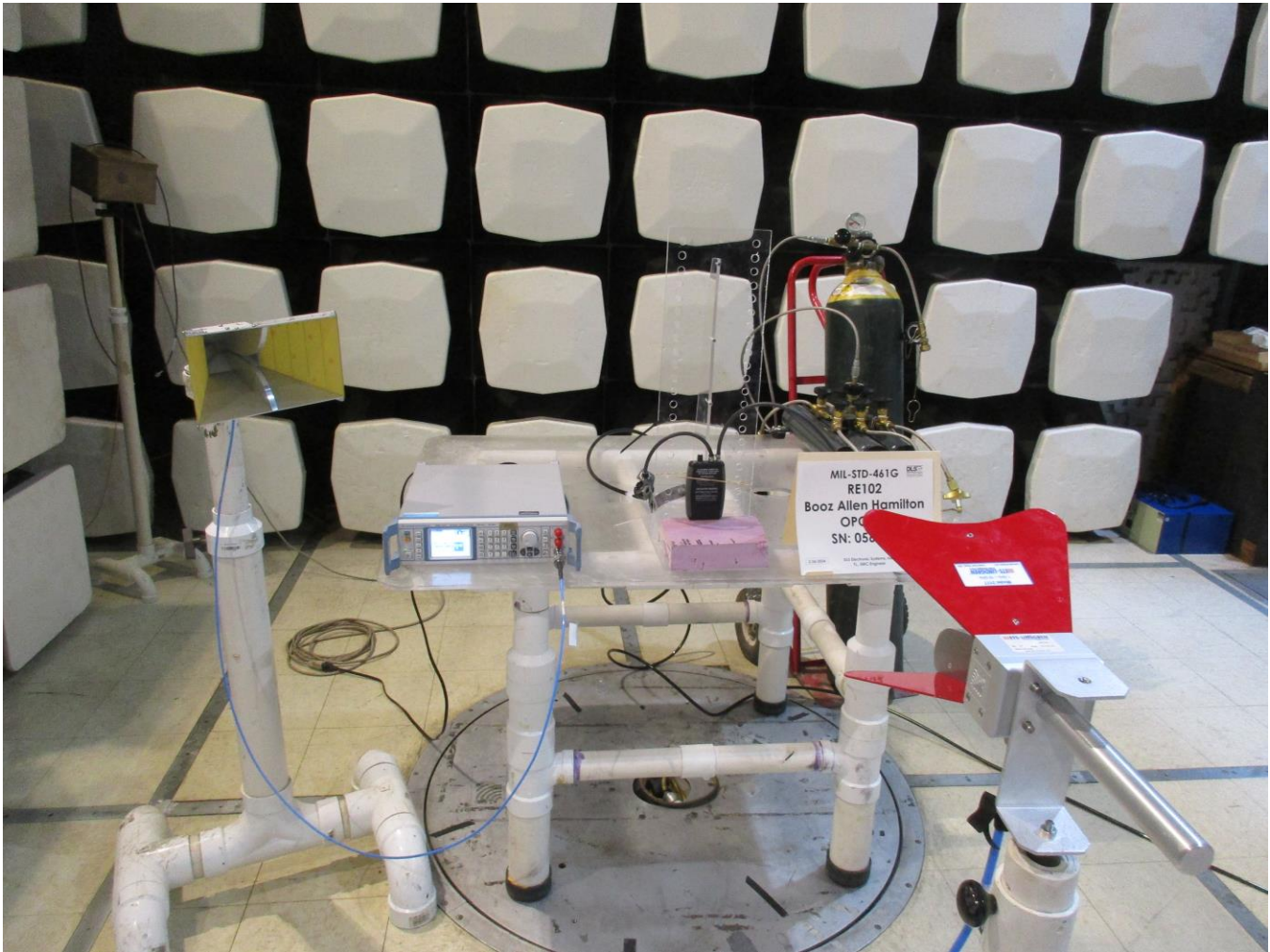

RE102 1-18GHz Antenna Continuity



Company: Product Management Office, Air Warrior
Model Tested: OPC-M2
Report Number: 28380
Project Number: 13049
Test: RE102, Electric Field Emissions

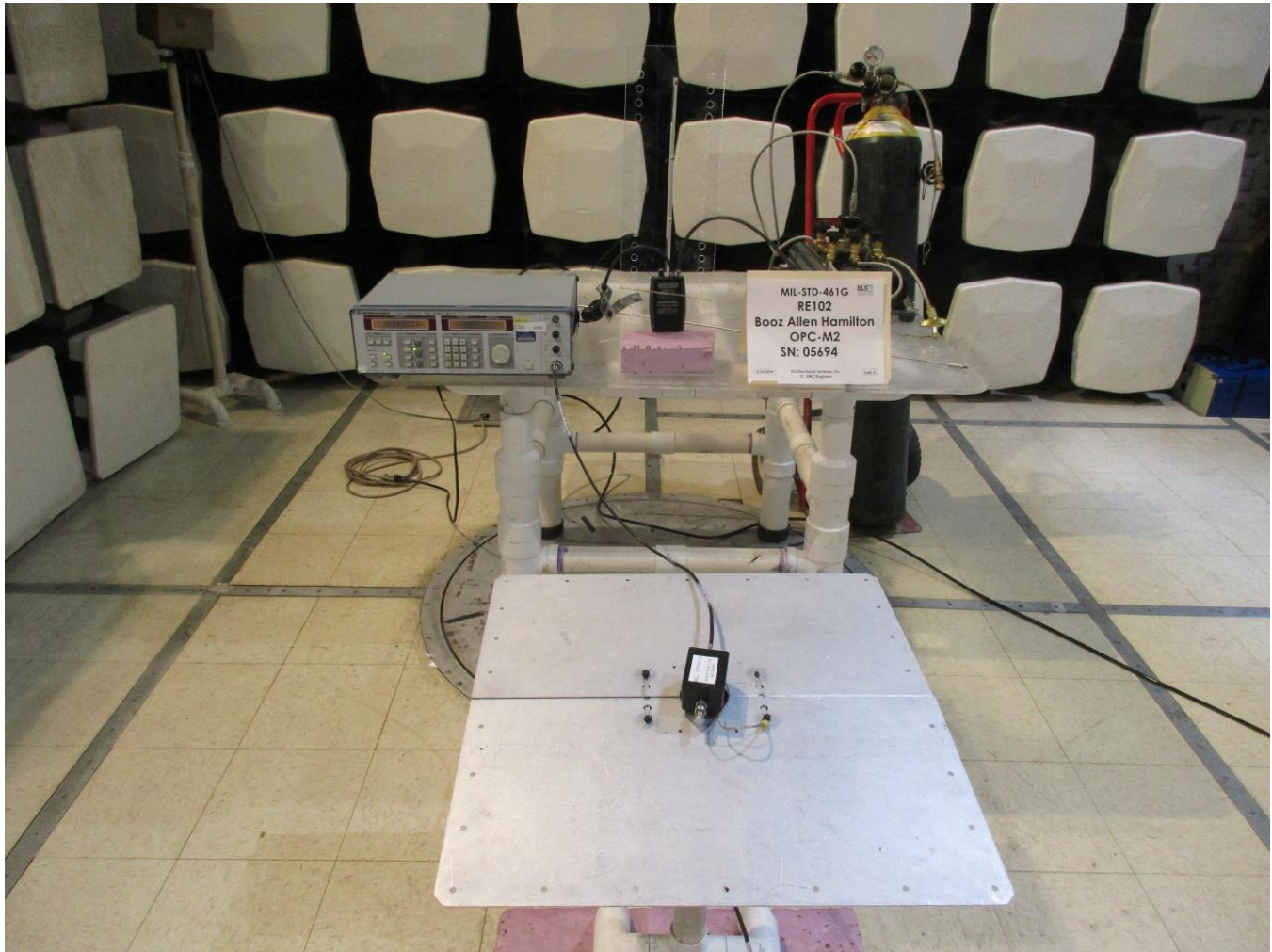

RE102 10kHz-30MHz System Verification



Company: Product Management Office, Air Warrior
Model Tested: OPC-M2
Report Number: 28380
Project Number: 13049
Test: RE102, Electric Field Emissions



RE102 30-1000MHz System Verification



Company: Product Management Office, Air Warrior
Model Tested: OPC-M2
Report Number: 28380
Project Number: 13049
Test: RE102, Electric Field Emissions

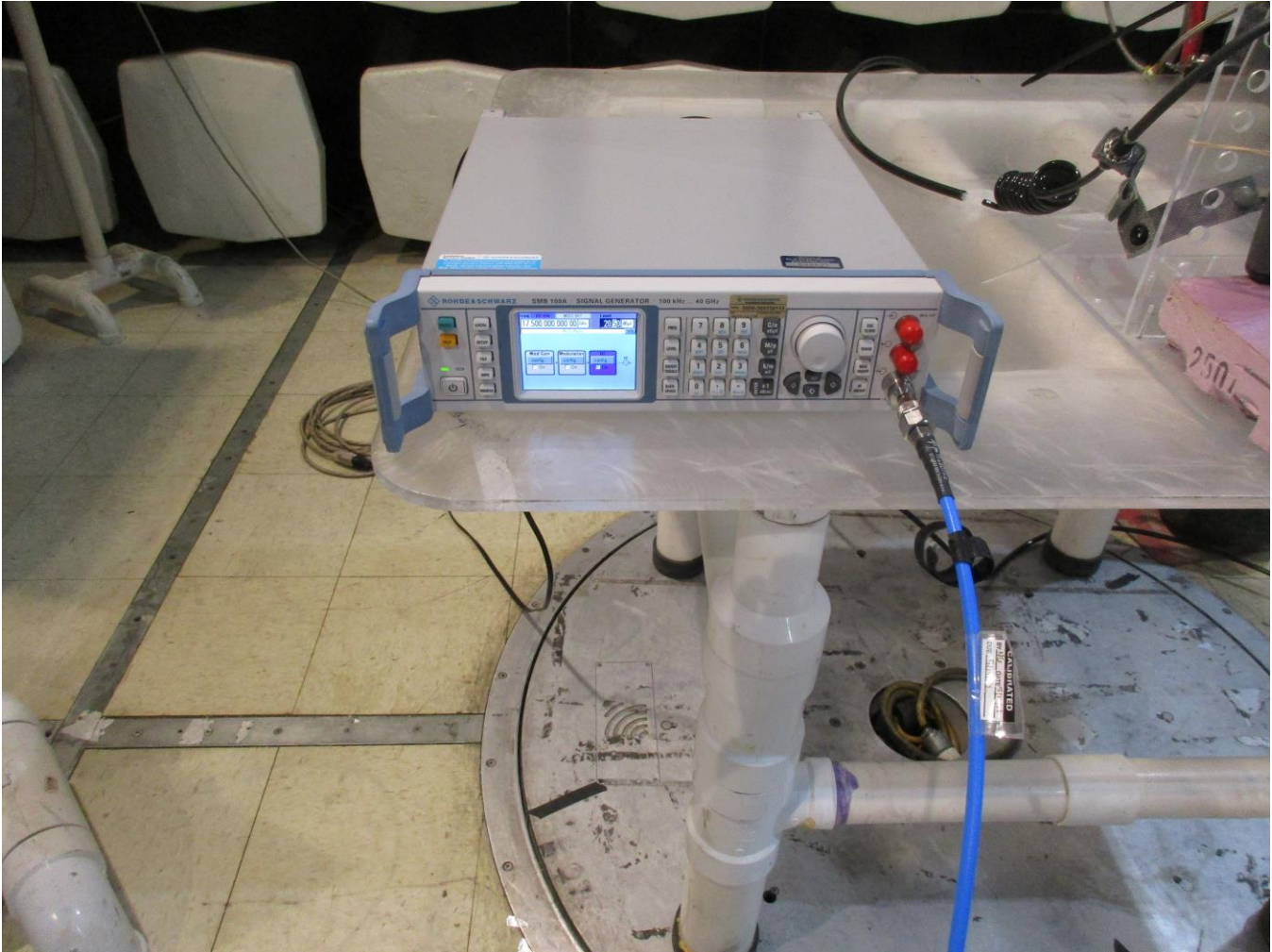

RE102 1-18GHz System Verification



Company: Product Management Office, Air Warrior
Model Tested: OPC-M2
Report Number: 28380
Project Number: 13049
Test: RE102, Electric Field Emissions

MIL-STD-461G

RE102

RADIATED EMISSIONS

ELECTRIC FIELD

USING

OPC-M2 EMI SOF TEST PLAN REV B 1.19.24 WITH REDLINES

TEST DATA



Company: Product Management Office, Air Warrior
Model Tested: OPC-M2
Report Number: 28380
Project Number: 13049
Test: RE102, Electric Field Emissions

D.L.S. Electronic Systems, Inc.

MIL-STD-461G RE102

10kHz-30MHz Emissions (peak)

Customer - Booz Allen Hamilton
EUT - OPC-M2 Oxygen Monitor SN:05694
Antenna Position - Center of EUT Boundary
Limit - Fixed Wing External or Helicopters
Power/Mode - Battery / Test Mode
Engineer - TL
Notes - Test Mode

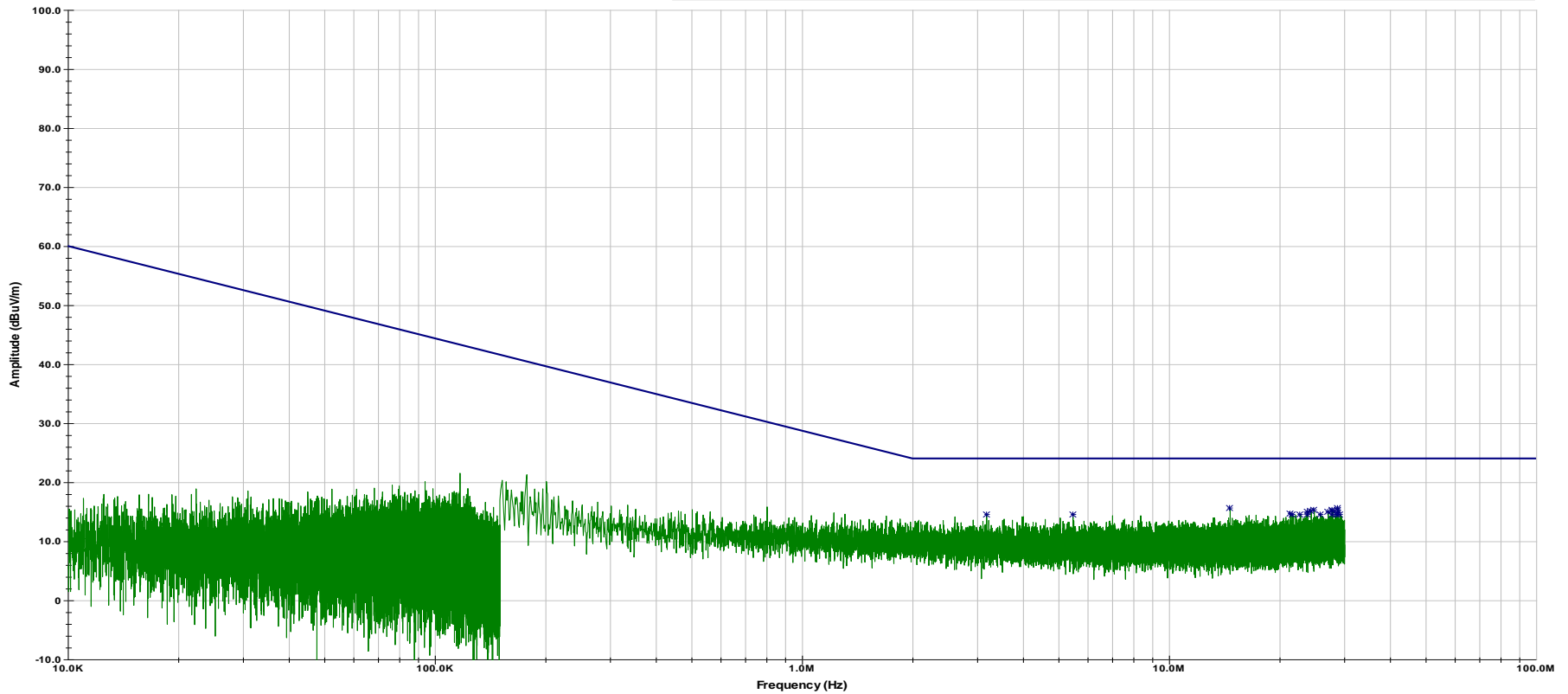

Last Data Update 02:00:09 PM, Monday, February 26, 2024

RE102 10kHz-30MHz Test Scan



Company: Product Management Office, Air Warrior
 Model Tested: OPC-M2
 Report Number: 28380
 Project Number: 13049
 Test: RE102, Electric Field Emissions

02:00:09 PM

Monday, February 26,
2024

Frequency	Complying Emissions (dB below limit)	Excessive Emissions (dB exceeding limit)	Highest Emissions (amplitude in dBuV/m)
03.177 MHz	-09.490	00.000	14.51
05.461 MHz	-09.410	00.000	14.59
14.635 MHz	-08.470	00.000	15.53
21.370 MHz	-09.300	00.000	14.70
21.594 MHz	-09.470	00.000	14.53
22.773 MHz	-09.430	00.000	14.57
23.809 MHz	-08.990	00.000	15.01
23.815 MHz	-09.410	00.000	14.59
24.339 MHz	-08.810	00.000	15.19
24.803 MHz	-08.750	00.000	15.25
25.842 MHz	-09.420	00.000	14.58
27.070 MHz	-09.090	00.000	14.91
27.742 MHz	-08.750	00.000	15.25
27.754 MHz	-09.450	00.000	14.55
27.895 MHz	-08.790	00.000	15.21
28.590 MHz	-09.480	00.000	14.52
28.833 MHz	-08.340	00.000	15.66
28.838 MHz	-08.770	00.000	15.23
28.849 MHz	-09.230	00.000	14.77
29.181 MHz	-09.490	00.000	14.51



Company: Product Management Office, Air Warrior
Model Tested: OPC-M2
Report Number: 28380
Project Number: 13049
Test: RE102, Electric Field Emissions

D.L.S. Electronic Systems, Inc.

MIL-STD-461G RE102

30-200MHz Emissions (peak)

Customer - Booz Allen Hamilton
EUT - OPC-M2 Oxygen Monitor SN:05694
Antenna Position - Center of EUT Boundary - Horizontal
Limit - Fixed Wing External or Helicopters
Power/Mode - Battery / Test Mode
Engineer - TL
Notes - Test Mode

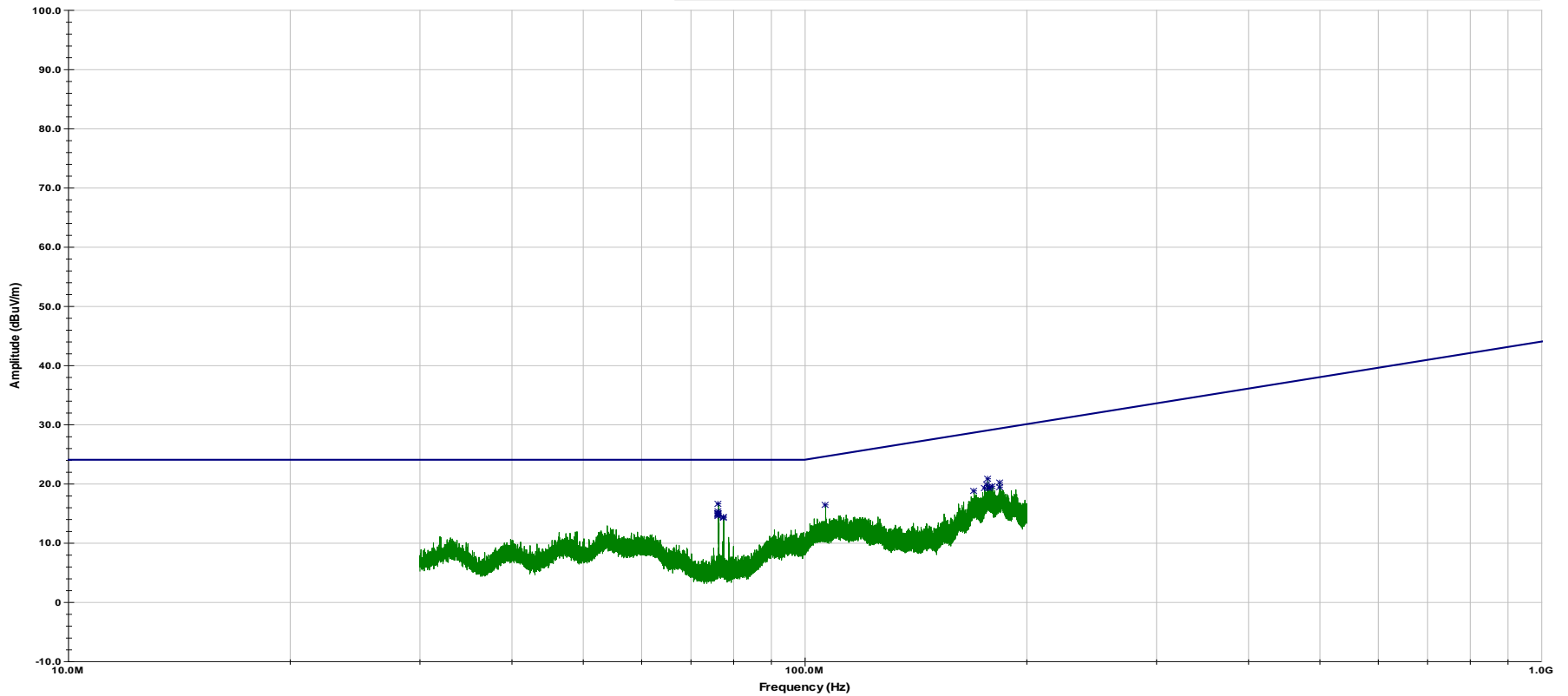

Last Data Update 03:12:28 PM, Monday, February 26, 2024

RE102 30-200MHz Horizontal Test Scan



Company: Product Management Office, Air Warrior
 Model Tested: OPC-M2
 Report Number: 28380
 Project Number: 13049
 Test: RE102, Electric Field Emissions

03:12:28 PM

Monday, February 26,
2024

Frequency	Complying Emissions (dB below limit)	Excessive Emissions (dB exceeding limit)	Highest Emissions (amplitude in dBuV/m)
76.325 MHz	-09.300	00.000	14.70
76.336 MHz	-09.400	00.000	14.60
76.346 MHz	-08.940	00.000	15.06
76.353 MHz	-08.950	00.000	15.05
76.364 MHz	-07.390	00.000	16.61
76.375 MHz	-08.650	00.000	15.35
76.382 MHz	-09.210	00.000	14.79
76.392 MHz	-09.040	00.000	14.96
77.554 MHz	-09.580	00.000	14.42
77.575 MHz	-09.790	00.000	14.21
106.640 MHz	-08.140	00.000	16.42
169.660 MHz	-09.870	00.000	18.71
175.340 MHz	-09.610	00.000	19.26
176.810 MHz	-09.120	00.000	19.82
177.090 MHz	-08.120	00.000	20.83
178.130 MHz	-09.840	00.000	19.16
178.490 MHz	-09.650	00.000	19.37
179.840 MHz	-09.590	00.000	19.50
183.800 MHz	-09.100	00.000	20.17
184.120 MHz	-09.880	00.000	19.41



Company: Product Management Office, Air Warrior
Model Tested: OPC-M2
Report Number: 28380
Project Number: 13049
Test: RE102, Electric Field Emissions

D.L.S. Electronic Systems, Inc.

MIL-STD-461G RE102

30-200MHz Emissions (peak)

Customer - Booz Allen Hamilton
EUT - OPC-M2 Oxygen Monitor SN:05694
Antenna Position - Center of EUT Boundary- Vertical
Limit - Fixed Wing External or Helicopters
Power/Mode - Battery / Test Mode
Engineer - TL
Notes - Test Mode

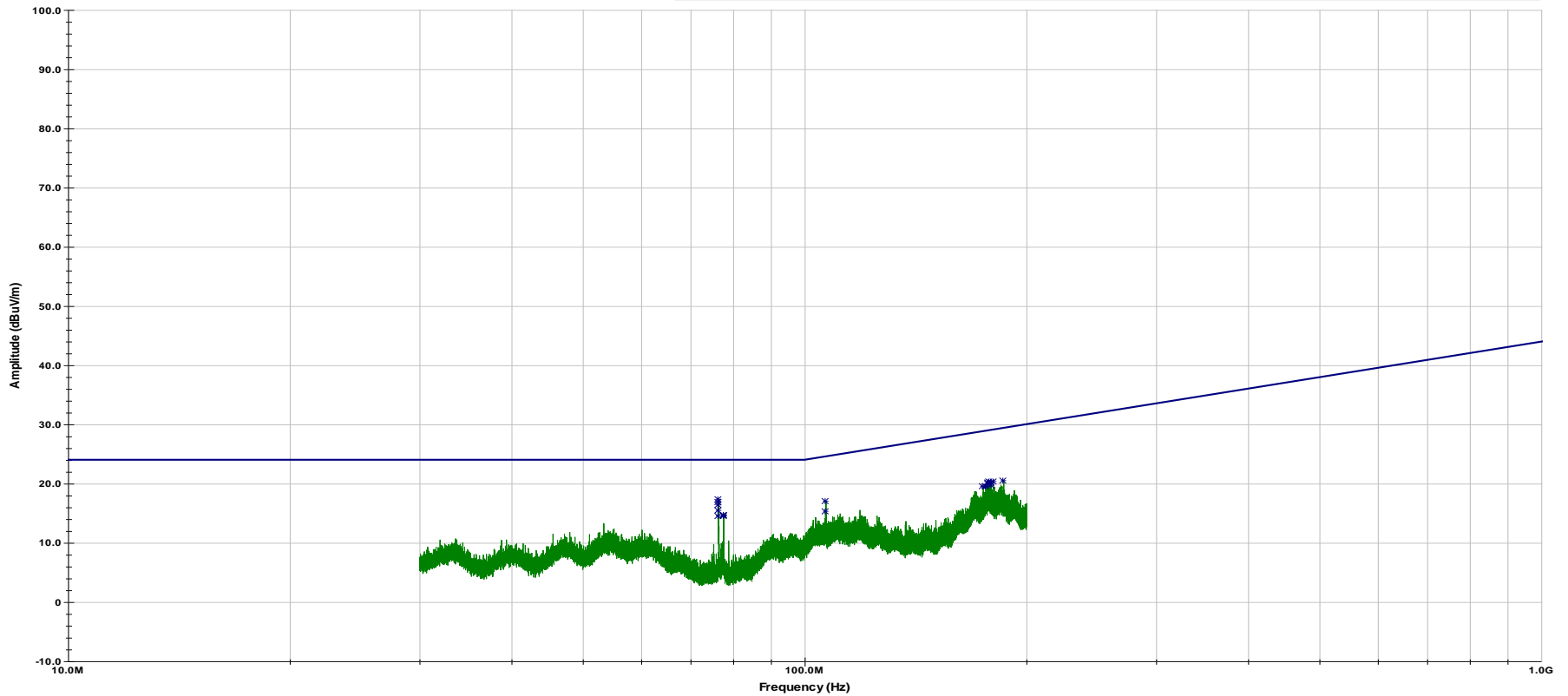

Last Data Update 03:01:49 PM, Monday, February 26, 2024

RE102 30-200MHz Vertical Test Scan



Company: Product Management Office, Air Warrior
 Model Tested: OPC-M2
 Report Number: 28380
 Project Number: 13049
 Test: RE102, Electric Field Emissions

03:01:49 PM

Monday, February 26,
2024

Frequency	Complying Emissions (dB below limit)	Excessive Emissions (dB exceeding limit)	Highest Emissions (amplitude in dBuV/m)
76.325 MHz	-09.450	00.000	14.55
76.339 MHz	-07.680	00.000	16.32
76.357 MHz	-07.090	00.000	16.91
76.371 MHz	-06.720	00.000	17.28
76.389 MHz	-08.630	00.000	15.37
77.540 MHz	-09.450	00.000	14.55
77.554 MHz	-09.340	00.000	14.66
77.568 MHz	-09.340	00.000	14.66
106.630 MHz	-09.180	00.000	15.37
106.780 MHz	-07.570	00.000	17.00
174.540 MHz	-09.340	00.000	19.49
176.030 MHz	-09.360	00.000	19.54
176.140 MHz	-09.310	00.000	19.60
177.040 MHz	-08.980	00.000	19.97
177.080 MHz	-08.850	00.000	20.10
177.880 MHz	-08.740	00.000	20.25
178.810 MHz	-08.890	00.000	20.15
178.970 MHz	-09.350	00.000	19.69
179.990 MHz	-08.790	00.000	20.30
186.100 MHz	-08.840	00.000	20.54



Company: Product Management Office, Air Warrior
Model Tested: OPC-M2
Report Number: 28380
Project Number: 13049
Test: RE102, Electric Field Emissions

D.L.S. Electronic Systems, Inc.

MIL-STD-461G RE102

200-1000MHz Emissions (peak)

Customer - Booz Allen Hamilton
EUT - OPC-M2 Oxygen Monitor SN:05694
Antenna Position - EUT - Horizontal
Limit - Fixed Wing External or Helicopters
Power/Mode - Batteries / Test Mode
Engineer - TL
Notes - Test Mode

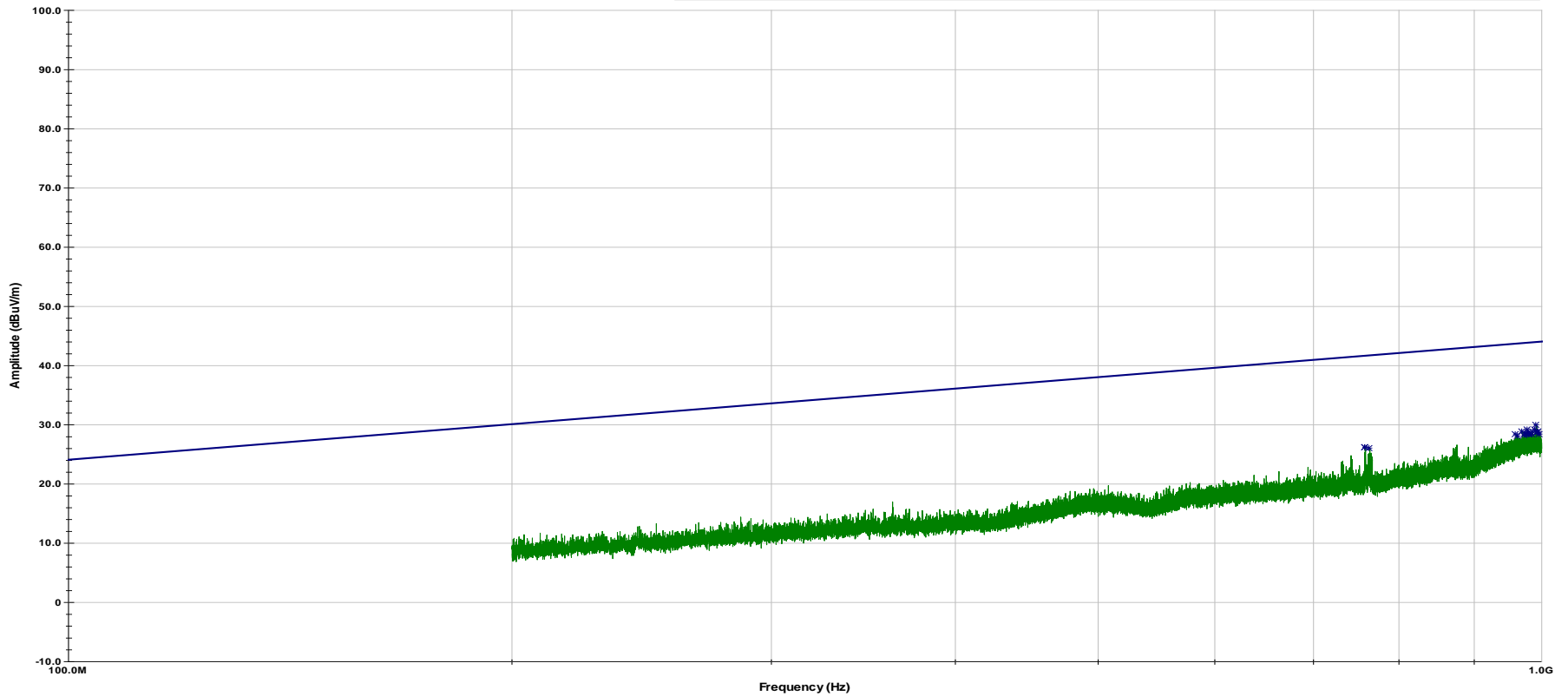

Last Data Update 04:33:19 PM, Monday, February 26, 2024

RE102 200-1000MHz Horizontal Test Scan



Company: Product Management Office, Air Warrior
Model Tested: OPC-M2
Report Number: 28380
Project Number: 13049
Test: RE102, Electric Field Emissions

04:33:19 PM

Monday, February 26,
2024

Frequency	Complying Emissions (dB below limit)	Excessive Emissions (dB exceeding limit)	Highest Emissions (amplitude in dBuV/m)
758.980 MHz	-15.410	00.000	26.15
759.340 MHz	-15.490	00.000	26.08
764.460 MHz	-15.690	00.000	25.94
961.140 MHz	-15.300	00.000	28.31
963.720 MHz	-15.630	00.000	28.00
970.680 MHz	-14.890	00.000	28.81
973.080 MHz	-15.590	00.000	28.12
975.720 MHz	-15.170	00.000	28.57
978.100 MHz	-14.570	00.000	29.19
979.980 MHz	-15.450	00.000	28.33
980.480 MHz	-15.080	00.000	28.70
982.320 MHz	-15.500	00.000	28.30
984.220 MHz	-15.520	00.000	28.30
986.080 MHz	-15.000	00.000	28.84
990.220 MHz	-14.680	00.000	29.19
992.300 MHz	-14.040	00.000	29.84
993.120 MHz	-15.240	00.000	28.65
993.900 MHz	-15.240	00.000	28.66
995.340 MHz	-15.170	00.000	28.74
997.500 MHz	-15.590	00.000	28.34



Company: Product Management Office, Air Warrior
Model Tested: OPC-M2
Report Number: 28380
Project Number: 13049
Test: RE102, Electric Field Emissions

D.L.S. Electronic Systems, Inc.

MIL-STD-461G RE102

200-1000MHz Emissions (peak)

Customer - Booz Allen Hamilton
EUT - OPC-M2 Oxygen Monitor SN:05694
Antenna Position - EUT - Vertical
Limit - Fixed Wing External or Helicopters
Power/Mode - Batteries / Test Mode
Engineer - TL
Notes - Test Mode

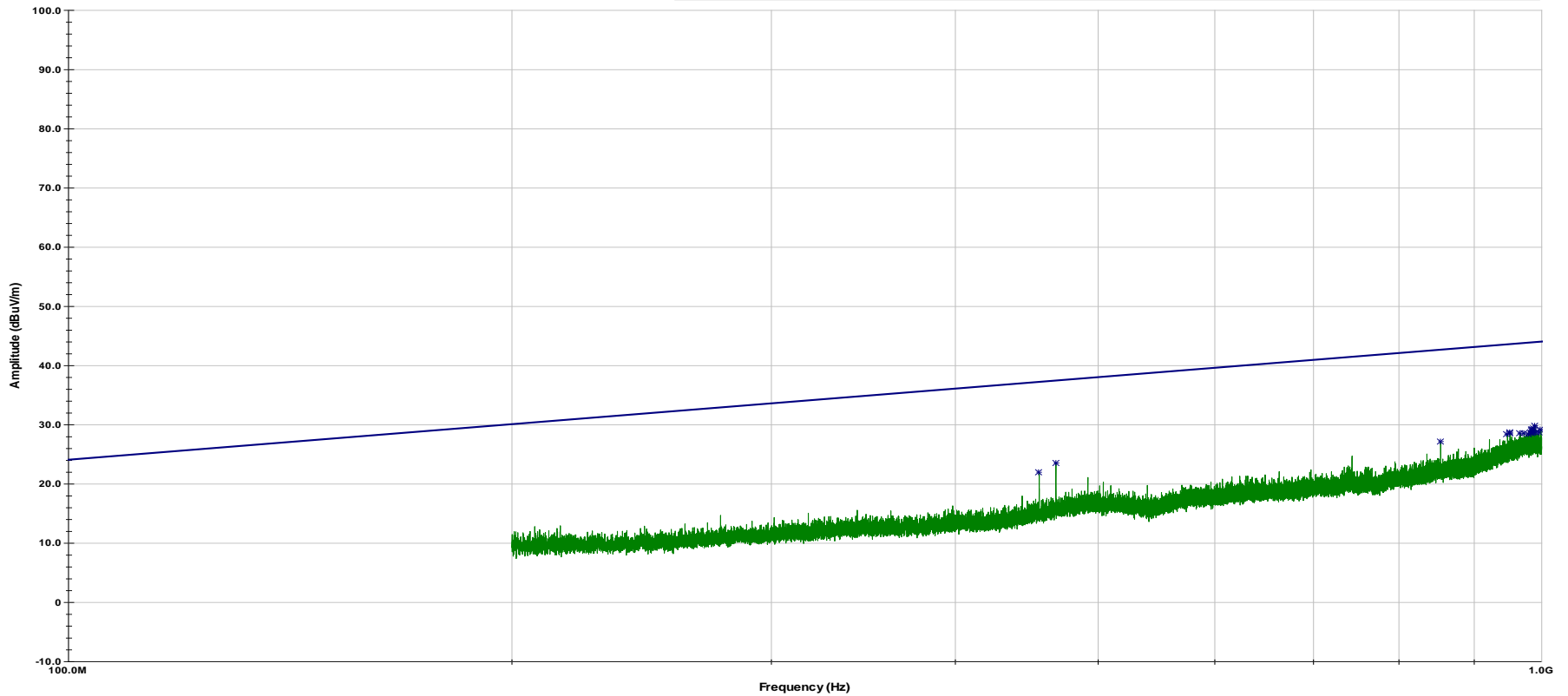

Last Data Update 09:30:28 AM, Tuesday, February 27, 2024

RE102 200-1000MHz Vertical Test Scan



Company: Product Management Office, Air Warrior
 Model Tested: OPC-M2
 Report Number: 28380
 Project Number: 13049
 Test: RE102, Electric Field Emissions

09:30:28 AM

Tuesday, February
 27, 2024

Frequency	Complying Emissions (dB below limit)	Excessive Emissions (dB exceeding limit)	Highest Emissions (amplitude in dBuV/m)
456.000 MHz	-15.260	00.000	21.88
468.020 MHz	-13.940	00.000	23.44
853.920 MHz	-15.430	00.000	27.15
947.980 MHz	-15.080	00.000	28.41
951.860 MHz	-14.900	00.000	28.63
952.260 MHz	-14.980	00.000	28.55
967.040 MHz	-15.110	00.000	28.55
973.040 MHz	-15.260	00.000	28.45
980.340 MHz	-15.390	00.000	28.39
982.860 MHz	-15.210	00.000	28.59
984.300 MHz	-15.330	00.000	28.49
984.640 MHz	-14.690	00.000	29.13
985.400 MHz	-14.890	00.000	28.94
986.360 MHz	-14.750	00.000	29.08
987.180 MHz	-15.240	00.000	28.60
988.900 MHz	-14.630	00.000	29.22
989.560 MHz	-14.120	00.000	29.74
990.920 MHz	-15.250	00.000	28.62
995.940 MHz	-15.330	00.000	28.59
998.780 MHz	-14.840	00.000	29.10



Company: Product Management Office, Air Warrior
Model Tested: OPC-M2
Report Number: 28380
Project Number: 13049
Test: RE102, Electric Field Emissions

D.L.S. Electronic Systems, Inc.

MIL-STD-461G RE102

1-18GHz Emissions (peak)

Customer - Booz Allen Hamilton
EUT - OPC-M2 Oxygen Monitor SN:05694
Antenna Position - EUT - Horizontal
Limit - Fixed Wing External or Helicopters
Power/Mode - N/A
Engineer - TL
Notes - Test Mode

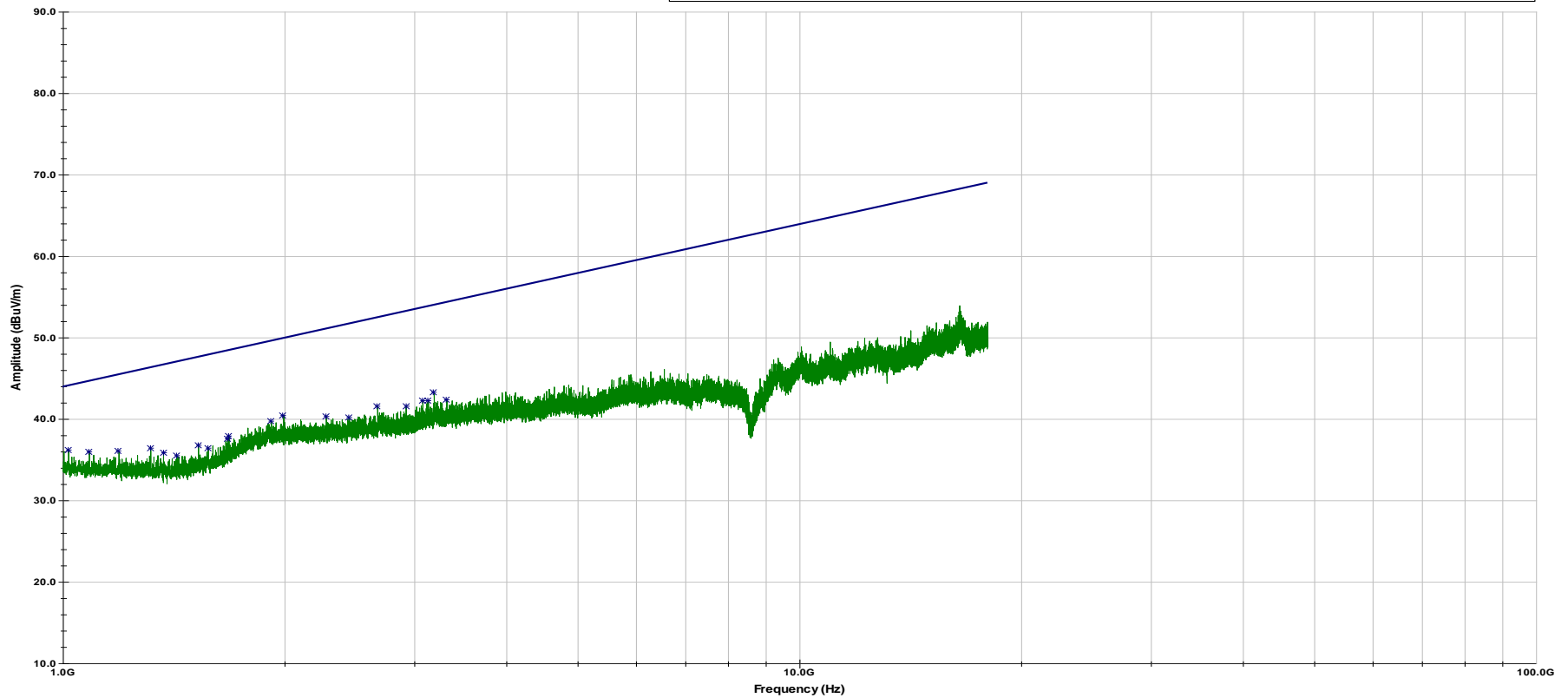

Last Data Update 12:27:24 PM, Tuesday, February 27, 2024

RE102 1-18GHz Horizontal Test Scan



Company: Product Management Office, Air Warrior
Model Tested: OPC-M2
Report Number: 28380
Project Number: 13049
Test: RE102, Electric Field Emissions

12:27:24 PM

Tuesday, February
27, 2024

Frequency	Complying Emissions (dB below limit)	Excessive Emissions (dB exceeding limit)	Highest Emissions (amplitude in dBuV/m)
01.017 GHz	-07.950	00.000	36.15
01.085 GHz	-08.670	00.000	35.99
01.190 GHz	-09.440	00.000	36.02
01.315 GHz	-09.960	00.000	36.36
01.368 GHz	-10.860	00.000	35.81
01.430 GHz	-11.600	00.000	35.45
01.526 GHz	-10.840	00.000	36.78
01.574 GHz	-11.530	00.000	36.36
01.672 GHz	-10.890	00.000	37.52
01.679 GHz	-10.610	00.000	37.83
01.917 GHz	-09.840	00.000	39.76
01.992 GHz	-09.480	00.000	40.44
02.276 GHz	-10.840	00.000	40.24
02.444 GHz	-11.530	00.000	40.17
02.673 GHz	-10.920	00.000	41.55
02.921 GHz	-11.700	00.000	41.54
03.078 GHz	-11.500	00.000	42.20
03.132 GHz	-11.590	00.000	42.25
03.189 GHz	-10.740	00.000	43.26
03.318 GHz	-11.960	00.000	42.39



Company: Product Management Office, Air Warrior
Model Tested: OPC-M2
Report Number: 28380
Project Number: 13049
Test: RE102, Electric Field Emissions

D.L.S. Electronic Systems, Inc.

MIL-STD-461G RE102

1-18GHz Emissions (peak)

Customer - Booz Allen Hamilton
EUT - OPC-M2 Oxygen Monitor SN:05694
Antenna Position - EUT - Vertical
Limit - Fixed Wing External or Helicopters
Power/Mode - N/A
Engineer - TL
Notes - Test Mode

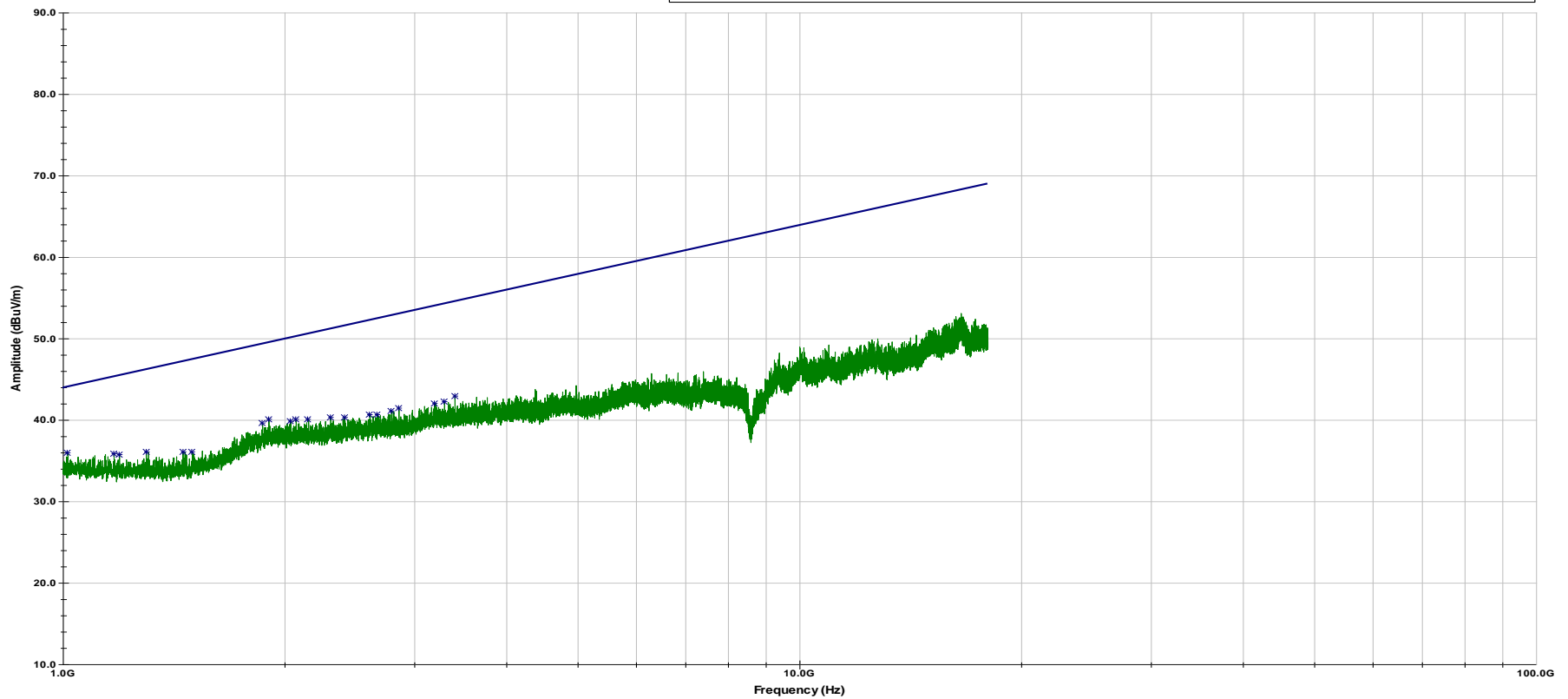

Last Data Update 01:01:05 PM, Tuesday, February 27, 2024

RE102 1-18GHz Vertical Test Scan



Company: Product Management Office, Air Warrior
Model Tested: OPC-M2
Report Number: 28380
Project Number: 13049
Test: RE102, Electric Field Emissions

01:01:05 PM

Tuesday, February
27, 2024

Frequency	Complying Emissions (dB below limit)	Excessive Emissions (dB exceeding limit)	Highest Emissions (amplitude in dBuV/m)
01.015 GHz	-08.180	00.000	35.91
01.172 GHz	-09.550	00.000	35.78
01.193 GHz	-09.780	00.000	35.69
01.297 GHz	-10.130	00.000	36.07
01.454 GHz	-11.110	00.000	36.09
01.498 GHz	-11.440	00.000	36.01
01.865 GHz	-09.790	00.000	39.56
01.902 GHz	-09.510	00.000	40.01
02.037 GHz	-10.230	00.000	39.89
02.072 GHz	-10.260	00.000	40.00
02.153 GHz	-10.500	00.000	40.10
02.308 GHz	-10.970	00.000	40.24
02.410 GHz	-11.330	00.000	40.24
02.610 GHz	-11.660	00.000	40.61
02.671 GHz	-11.820	00.000	40.65
02.794 GHz	-11.770	00.000	41.09
02.856 GHz	-11.650	00.000	41.39
03.193 GHz	-11.980	00.000	42.04
03.294 GHz	-12.110	00.000	42.17
03.403 GHz	-11.680	00.000	42.88



Company: Product Management Office, Air Warrior
Model Tested: OPC-M2
Report Number: 28380
Project Number: 13049
Test: RE102, Electric Field Emissions

MIL-STD-461G

RE102

RADIATED EMISSIONS

ELECTRIC FIELD

USING

OPC-M2 EMI SOF TEST PLAN REV B 1.19.24 WITH REDLINES

CONTINUITY CHECK DATA



Company: Product Management Office, Air Warrior
Model Tested: OPC-M2
Report Number: 28380
Project Number: 13049
Test: RE102, Electric Field Emissions

D.L.S. Electronic Systems, Inc.

MIL-STD-461G RE102

10kHz-30MHz Emissions (peak)

Customer - Booz Allen Hamilton
EUT - OPC-M2 Oxygen Monitor SN:05694
Antenna Position - Center of EUT Boundary
Limit - Fixed Wing External or Helicopters
Power/Mode - N/A
Engineer - TL
Notes - Antenna Continuity - Intentional Radiator @ 29MHz

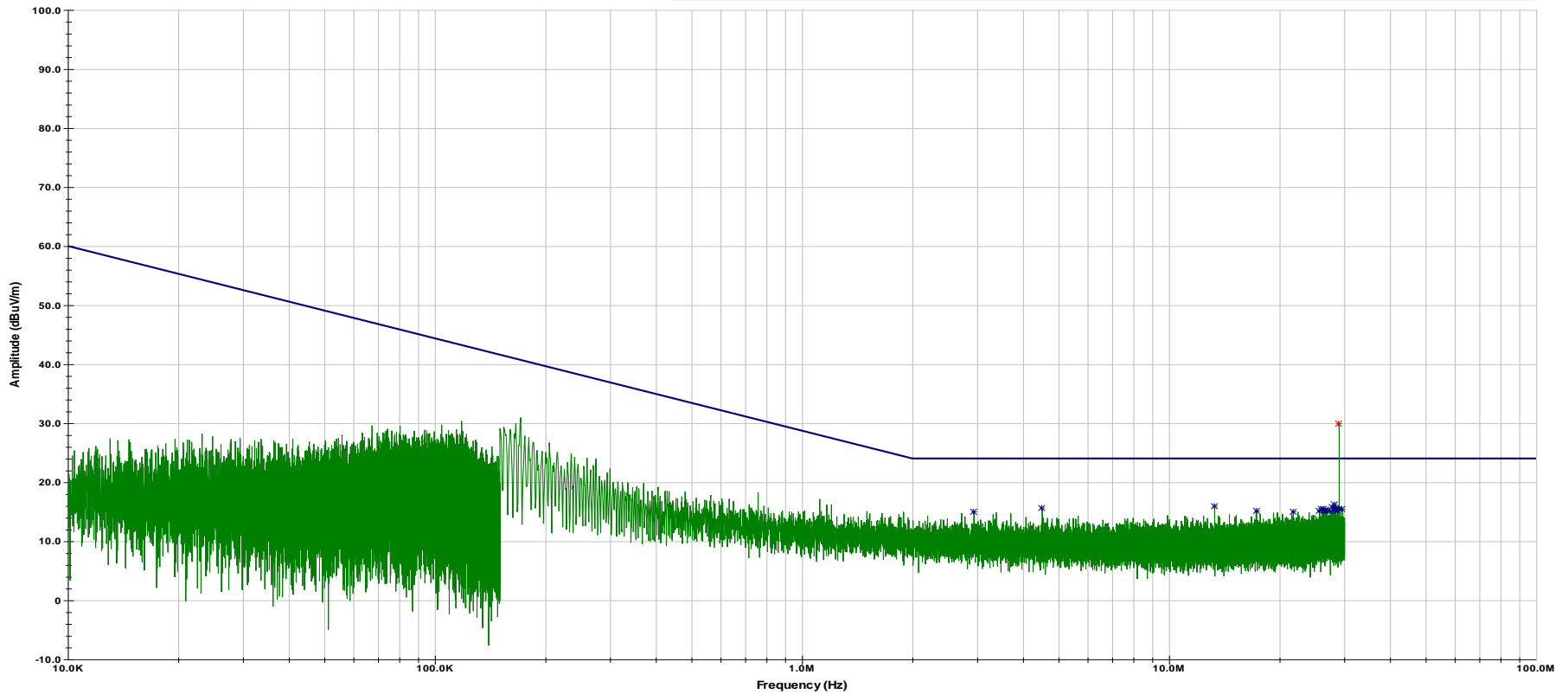

Last Data Update 12:33:46 PM, Monday, February 26, 2024

RE102 10kHz-30MHz Antenna Continuity Scan



Company: Product Management Office, Air Warrior
Model Tested: OPC-M2
Report Number: 28380
Project Number: 13049
Test: RE102, Electric Field Emissions

12:33:46 PM

Monday, February 26,
2024

Frequency	Complying Emissions (dB below limit)	Excessive Emissions (dB exceeding limit)	Highest Emissions (amplitude in dBuV/m)
02.934 MHz	-08.960	00.000	15.04
04.502 MHz	-08.440	00.000	15.56
13.280 MHz	-08.090	00.000	15.91
17.257 MHz	-08.800	00.000	15.20
21.750 MHz	-08.960	00.000	15.04
25.656 MHz	-08.830	00.000	15.17
26.050 MHz	-08.550	00.000	15.45
26.284 MHz	-08.630	00.000	15.37
26.577 MHz	-08.920	00.000	15.08
26.728 MHz	-08.870	00.000	15.13
26.793 MHz	-08.660	00.000	15.34
27.511 MHz	-08.800	00.000	15.20
27.870 MHz	-08.250	00.000	15.75
28.100 MHz	-08.740	00.000	15.26
28.242 MHz	-07.770	00.000	16.23
28.405 MHz	-08.340	00.000	15.66
28.751 MHz	-08.820	00.000	15.18
28.956 MHz	-08.590	00.000	15.41
29.000 MHz	00.000	05.910	29.91
29.615 MHz	-08.610	00.000	15.39



Company: Product Management Office, Air Warrior
Model Tested: OPC-M2
Report Number: 28380
Project Number: 13049
Test: RE102, Electric Field Emissions

D.L.S. Electronic Systems, Inc.

MIL-STD-461G RE102

30-200MHz Emissions (peak)

Customer - Booz Allen Hamilton
EUT - OPC-M2 Oxygen Monitor SN:05694
Antenna Position - EUT- Vertical
Limit - Fixed Wing External or Helicopters
Power/Mode - N/A
Engineer - TL
Notes - Antenna Continuity - Intentional Radiator @ 197 MHz

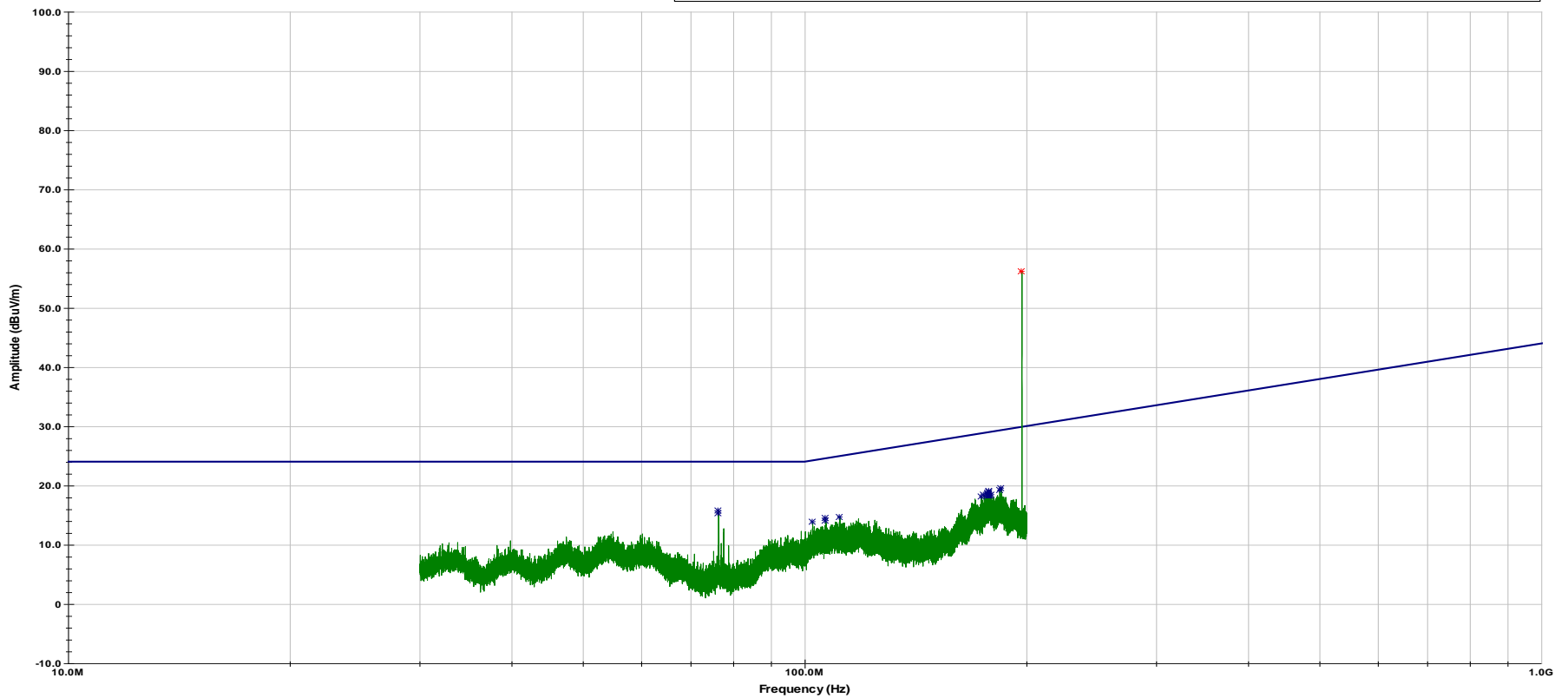

Last Data Update 02:43:40 PM, Monday, February 26, 2024

RE102 30-200MHz Antenna Continuity Scan



Company: Product Management Office, Air Warrior
 Model Tested: OPC-M2
 Report Number: 28380
 Project Number: 13049
 Test: RE102, Electric Field Emissions

02:43:40 PM

Monday, February 26,
2024

Frequency	Complying Emissions (dB below limit)	Excessive Emissions (dB exceeding limit)	Highest Emissions (amplitude in dBuV/m)
76.339 MHz	-08.190	00.000	15.81
76.389 MHz	-08.720	00.000	15.28
102.420 MHz	-10.330	00.000	13.88
106.630 MHz	-10.040	00.000	14.52
106.750 MHz	-10.580	00.000	13.98
111.520 MHz	-10.210	00.000	14.73
173.430 MHz	-10.710	00.000	18.06
175.140 MHz	-10.420	00.000	18.44
177.070 MHz	-10.560	00.000	18.39
177.160 MHz	-10.210	00.000	18.74
177.510 MHz	-10.440	00.000	18.53
177.570 MHz	-10.610	00.000	18.37
177.630 MHz	-09.900	00.000	19.08
177.690 MHz	-10.760	00.000	18.23
177.960 MHz	-10.050	00.000	18.94
178.200 MHz	-10.660	00.000	18.35
179.150 MHz	-10.670	00.000	18.38
183.800 MHz	-10.010	00.000	19.27
184.770 MHz	-09.790	00.000	19.53
197.000 MHz	00.000	26.350	56.22



Company: Product Management Office, Air Warrior
Model Tested: OPC-M2
Report Number: 28380
Project Number: 13049
Test: RE102, Electric Field Emissions

D.L.S. Electronic Systems, Inc.

MIL-STD-461G RE102

200-1000MHz Emissions (peak)

Customer - Booz Allen Hamilton
EUT - OPC-M2 Oxygen Monitor SN:05694
Antenna Position - EUT - Vertical
Limit - Fixed Wing External or Helicopters
Power/Mode - N/A
Engineer - TL
Notes - Antenna Continuity - Intentional Radiator @ 990MHz

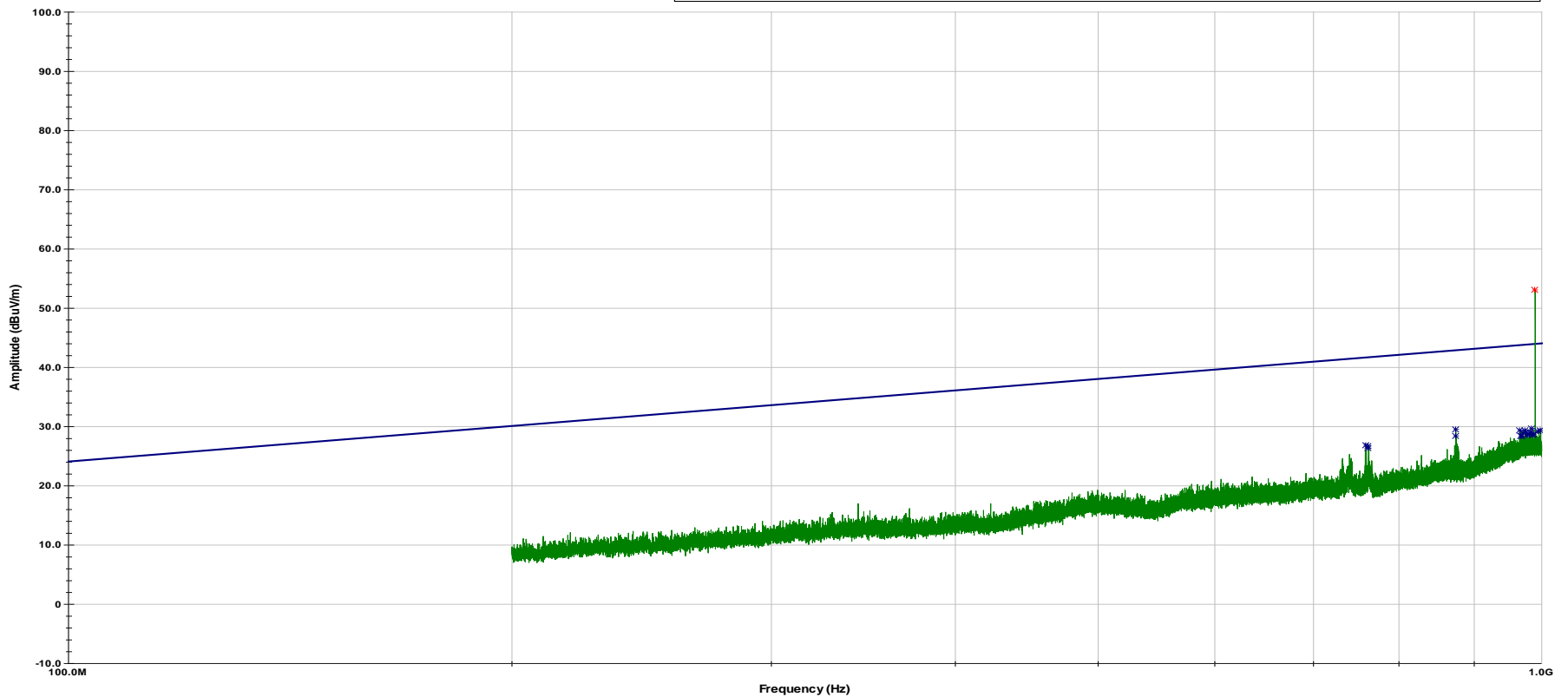

Last Data Update 04:03:11 PM, Monday, February 26, 2024

RE102 200-1000MHz Antenna Continuity Scan



Company: Product Management Office, Air Warrior
Model Tested: OPC-M2
Report Number: 28380
Project Number: 13049
Test: RE102, Electric Field Emissions

04:03:11 PM

Monday, February 26,
2024

Frequency	Complying Emissions (dB below limit)	Excessive Emissions (dB exceeding limit)	Highest Emissions (amplitude in dBuV/m)
760.060 MHz	-14.860	00.000	26.71
763.300 MHz	-15.000	00.000	26.61
763.360 MHz	-15.300	00.000	26.31
874.460 MHz	-13.380	00.000	29.41
875.080 MHz	-14.400	00.000	28.40
967.380 MHz	-14.330	00.000	29.34
968.400 MHz	-15.270	00.000	28.40
969.560 MHz	-15.320	00.000	28.37
971.080 MHz	-14.760	00.000	28.94
974.900 MHz	-14.510	00.000	29.22
977.460 MHz	-14.770	00.000	28.99
977.880 MHz	-15.300	00.000	28.46
981.600 MHz	-15.080	00.000	28.71
983.420 MHz	-14.810	00.000	29.00
985.360 MHz	-14.310	00.000	29.51
986.360 MHz	-15.290	00.000	28.55
988.760 MHz	-15.250	00.000	28.60
990.000 MHz	00.000	09.130	53.00
995.800 MHz	-14.830	00.000	29.09
998.280 MHz	-14.660	00.000	29.28



Company: Product Management Office, Air Warrior
Model Tested: OPC-M2
Report Number: 28380
Project Number: 13049
Test: RE102, Electric Field Emissions

D.L.S. Electronic Systems, Inc.

MIL-STD-461G RE102

1-18GHz Emissions (peak)

Customer - Booz Allen Hamilton
EUT - OPC-M2 Oxygen Monitor SN:05694
Antenna Position - EUT - Vertical
Limit - Fixed Wing External or Helicopters
Power/Mode - N/A
Engineer - TL
Notes - Antenna Continuity - Intentional Radiator @ 17.5GHz

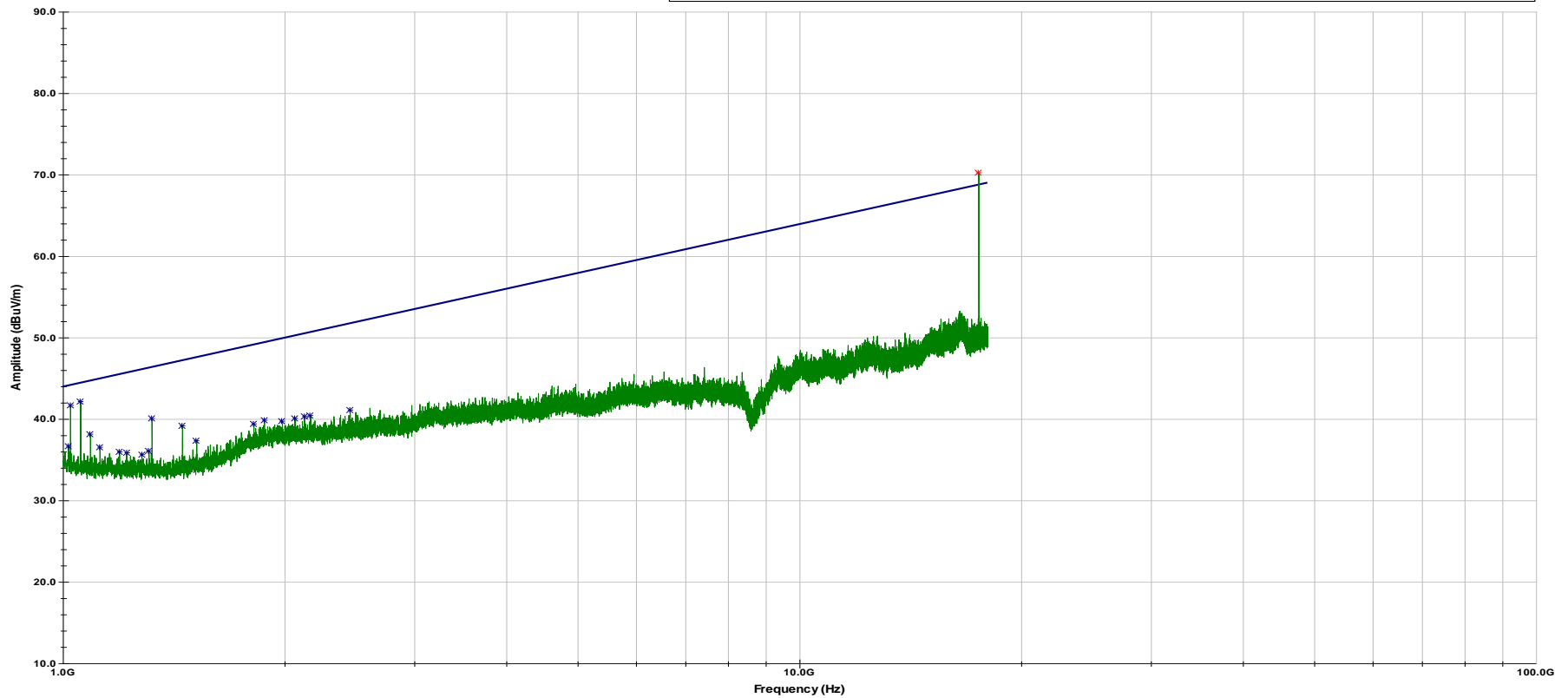

Last Data Update 11:41:25 AM, Tuesday, February 27, 2024

RE102 1-18GHz Antenna Continuity Scan



Company: Product Management Office, Air Warrior
 Model Tested: OPC-M2
 Report Number: 28380
 Project Number: 13049
 Test: RE102, Electric Field Emissions

11:41:25 AM

Tuesday, February
27, 2024

Frequency	Complying Emissions (dB below limit)	Excessive Emissions (dB exceeding limit)	Highest Emissions (amplitude in dBuV/m)
01.017 GHz	-07.520	00.000	36.57
01.023 GHz	-02.510	00.000	41.64
01.056 GHz	-02.330	00.000	42.09
01.089 GHz	-06.630	00.000	38.06
01.122 GHz	-08.460	00.000	36.49
01.193 GHz	-09.520	00.000	35.96
01.221 GHz	-09.830	00.000	35.85
01.279 GHz	-10.430	00.000	35.65
01.308 GHz	-10.250	00.000	36.03
01.320 GHz	-06.310	00.000	40.05
01.452 GHz	-08.000	00.000	39.18
01.518 GHz	-10.230	00.000	37.34
01.815 GHz	-09.750	00.000	39.37
01.876 GHz	-09.580	00.000	39.83
01.984 GHz	-10.150	00.000	39.74
02.067 GHz	-10.150	00.000	40.09
02.126 GHz	-10.230	00.000	40.26
02.167 GHz	-10.250	00.000	40.40
02.453 GHz	-10.630	00.000	41.09
17.500 GHz	00.000	01.450	70.21



Company: Product Management Office, Air Warrior
Model Tested: OPC-M2
Report Number: 28380
Project Number: 13049
Test: RE102, Electric Field Emissions

MIL-STD-461G

RE102

RADIATED EMISSIONS

ELECTRIC FIELD

USING

OPC-M2 EMI SOF TEST PLAN REV B 1.19.24 WITH REDLINES

VERIFICATION DATA



Company: Product Management Office, Air Warrior
Model Tested: OPC-M2
Report Number: 28380
Project Number: 13049
Test: RE102, Electric Field Emissions

D.L.S. Electronic Systems, Inc.

MIL-STD-461G RE102

10kHz-30MHz Emissions (peak)

Customer - Booz Allen Hamilton
EUT - OPC-M2 Oxygen Monitor SN:05694
Antenna Position - Center of EUT Boundary
Limit - Fixed Wing External or Helicopters
Power/Mode - N/A
Engineer - TL
Notes - System Verification - 6dB Below Limit @ 10.5kHz, 12MHz, 29.5MHz

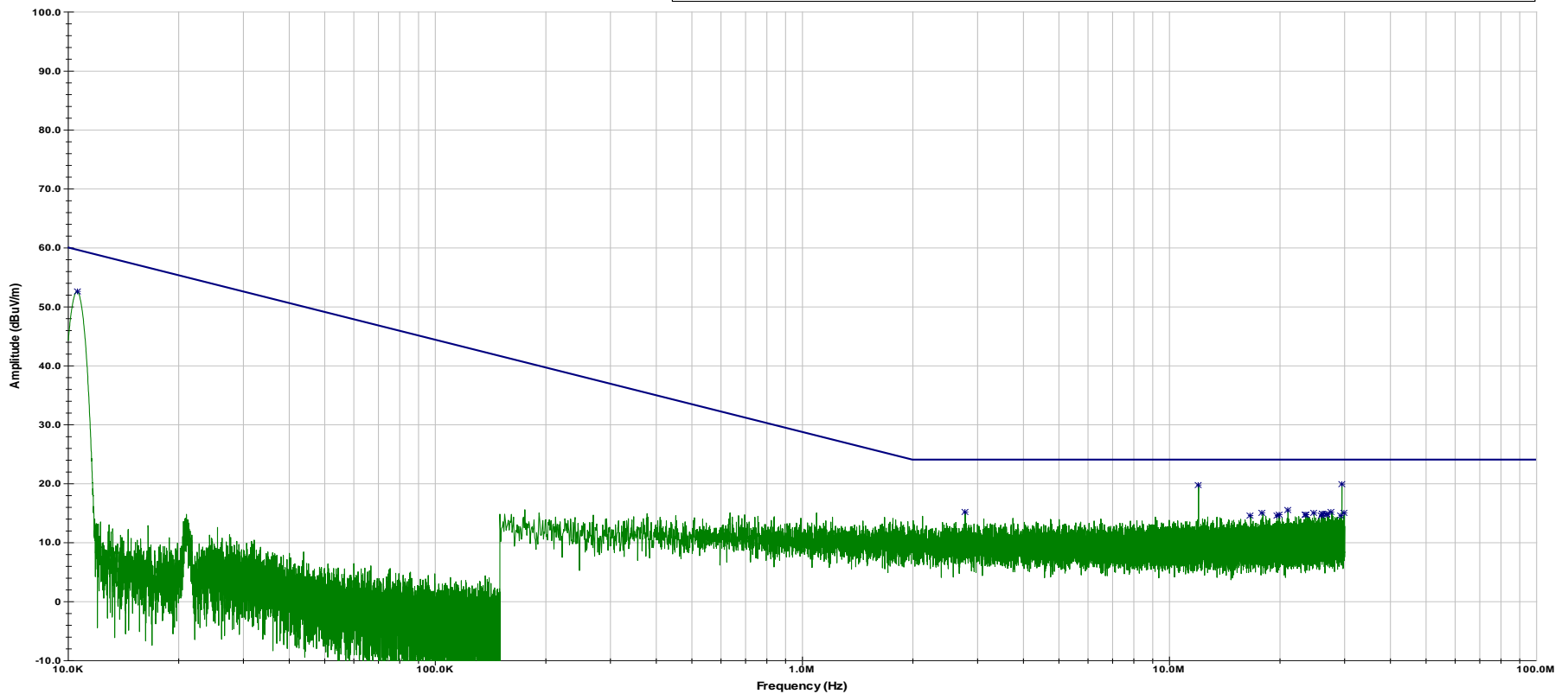

Last Data Update 12:04:00 PM, Monday, February 26, 2024

RE102 10kHz-30MHz System Verification Scan



Company: Product Management Office, Air Warrior
 Model Tested: OPC-M2
 Report Number: 28380
 Project Number: 13049
 Test: RE102, Electric Field Emissions

12:04:00 PM

Monday, February 26,
2024

Frequency	Complying Emissions (dB below limit)	Excessive Emissions (dB exceeding limit)	Highest Emissions (amplitude in dBuV/m)
10.604 kHz	-07.050	00.000	52.55
02.778 MHz	-08.880	00.000	15.12
12.000 MHz	-04.230	00.000	19.77
16.650 MHz	-09.480	00.000	14.52
17.970 MHz	-09.070	00.000	14.93
19.623 MHz	-09.480	00.000	14.52
19.913 MHz	-09.390	00.000	14.61
21.030 MHz	-08.600	00.000	15.40
23.503 MHz	-09.300	00.000	14.70
23.717 MHz	-09.260	00.000	14.74
24.780 MHz	-09.070	00.000	14.93
25.959 MHz	-09.410	00.000	14.59
26.140 MHz	-09.220	00.000	14.78
26.161 MHz	-09.230	00.000	14.77
26.922 MHz	-09.270	00.000	14.73
26.929 MHz	-09.240	00.000	14.76
27.702 MHz	-08.800	00.000	15.20
29.314 MHz	-09.450	00.000	14.55
29.500 MHz	-04.120	00.000	19.88
29.962 MHz	-09.010	00.000	14.99



Company: Product Management Office, Air Warrior
Model Tested: OPC-M2
Report Number: 28380
Project Number: 13049
Test: RE102, Electric Field Emissions

D.L.S. Electronic Systems, Inc.

MIL-STD-461G RE102

30-200MHz Emissions (peak)

Customer - Booz Allen Hamilton
EUT - OPC-M2 Oxygen Monitor SN:05694
Antenna Position - Center of EUT Boundary- Vertical
Limit - Fixed Wing External or Helicopters
Power/Mode - N/A
Engineer - TL
Notes - System Verification - 6dB Below Limit @ 197MHz

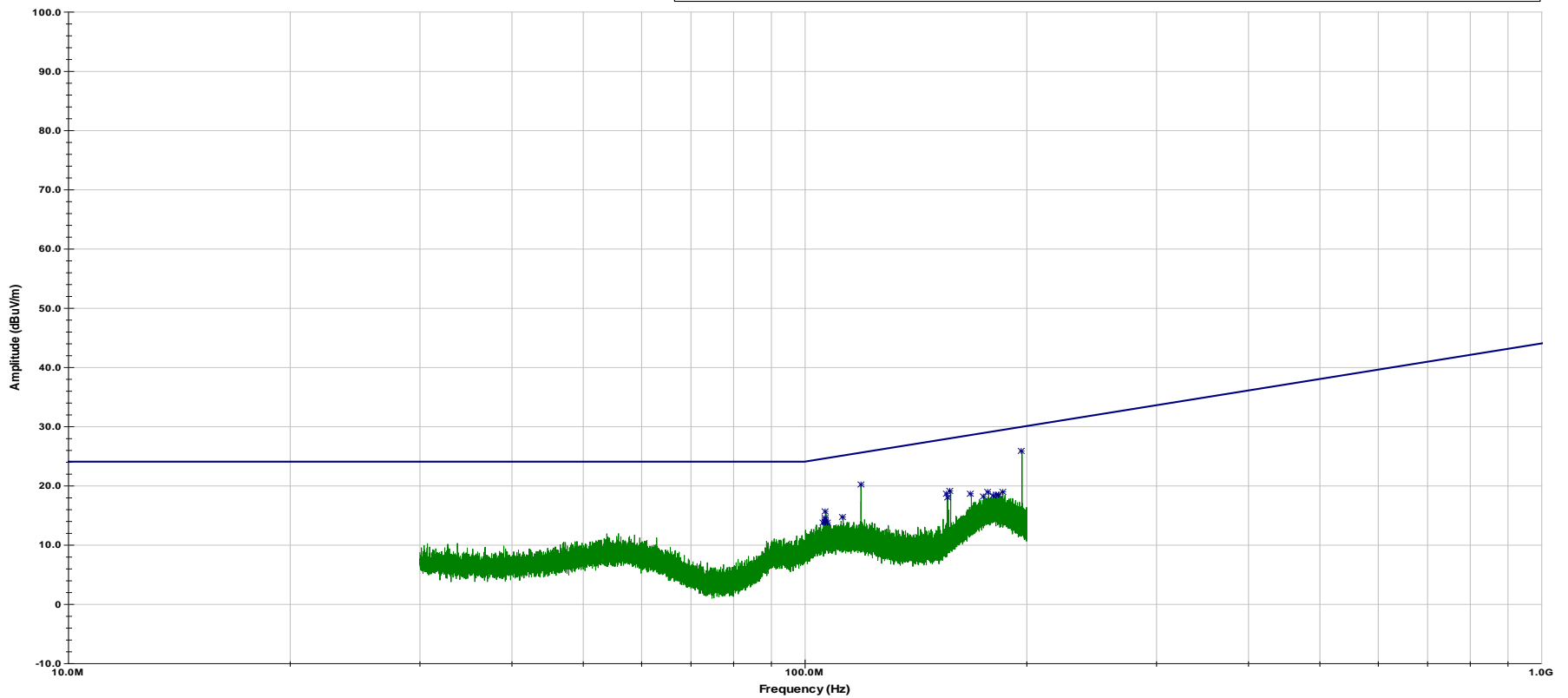

Last Data Update 01:24:45 PM, Monday, February 26, 2024

RE102 30-200MHz System Verification Scan



Company: Product Management Office, Air Warrior
Model Tested: OPC-M2
Report Number: 28380
Project Number: 13049
Test: RE102, Electric Field Emissions

01:24:45 PM

Monday, February 26,
2024

Frequency	Complying Emissions (dB below limit)	Excessive Emissions (dB exceeding limit)	Highest Emissions (amplitude in dBuV/m)
106.000 MHz	-10.780	00.000	13.73
106.680 MHz	-10.400	00.000	14.16
106.740 MHz	-09.000	00.000	15.57
106.760 MHz	-10.670	00.000	13.90
106.780 MHz	-10.640	00.000	13.93
106.820 MHz	-10.120	00.000	14.45
107.230 MHz	-10.840	00.000	13.76
112.650 MHz	-10.290	00.000	14.74
119.110 MHz	-05.320	00.000	20.19
155.900 MHz	-09.190	00.000	18.66
156.130 MHz	-09.970	00.000	17.89
157.650 MHz	-08.820	00.000	19.12
168.220 MHz	-09.930	00.000	18.58
175.020 MHz	-10.800	00.000	18.05
177.540 MHz	-09.990	00.000	18.98
180.100 MHz	-10.850	00.000	18.25
182.410 MHz	-10.810	00.000	18.40
183.630 MHz	-10.800	00.000	18.47
185.550 MHz	-10.510	00.000	18.84
197.000 MHz	-04.030	00.000	25.85



Company: Product Management Office, Air Warrior
Model Tested: OPC-M2
Report Number: 28380
Project Number: 13049
Test: RE102, Electric Field Emissions

D.L.S. Electronic Systems, Inc.

MIL-STD-461G RE102

200-1000MHz Emissions (peak)

Customer - Booz Allen Hamilton
EUT - OPC-M2 Oxygen Monitor SN:05694
Antenna Position - EUT - Vertical
Limit - Fixed Wing External or Helicopters
Power/Mode - N/A
Engineer - TL
Notes - System Verification - 6dB Below Limit @ 990MHz

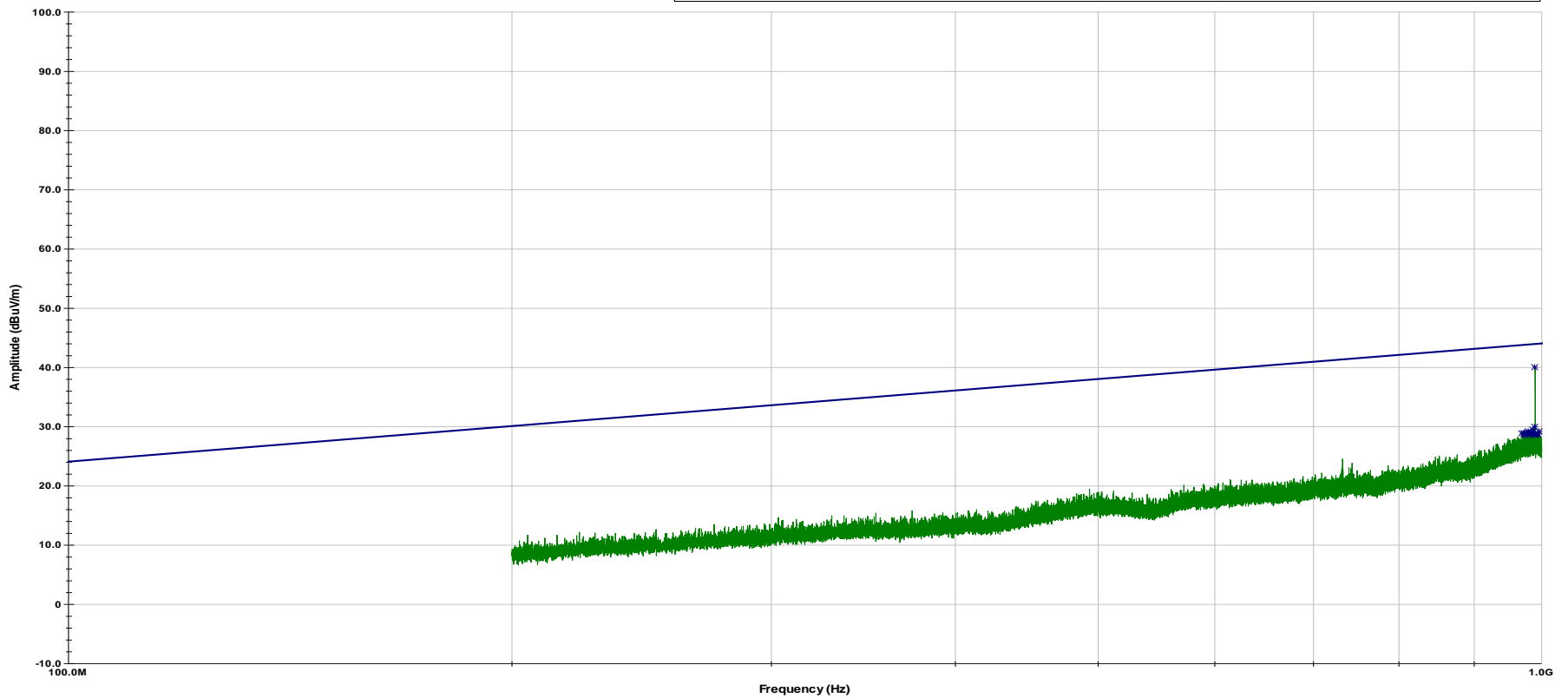

Last Data Update 03:29:17 PM, Monday, February 26, 2024

RE102 200-1000MHz System Verification Scan



Company: Product Management Office, Air Warrior
 Model Tested: OPC-M2
 Report Number: 28380
 Project Number: 13049
 Test: RE102, Electric Field Emissions

03:29:17 PM

Monday, February 26,
2024

Frequency	Complying Emissions (dB below limit)	Excessive Emissions (dB exceeding limit)	Highest Emissions (amplitude in dBuV/m)
970.040 MHz	-14.910	00.000	28.78
972.960 MHz	-15.150	00.000	28.57
973.140 MHz	-14.940	00.000	28.78
977.200 MHz	-14.910	00.000	28.85
978.900 MHz	-14.870	00.000	28.90
979.280 MHz	-14.680	00.000	29.09
980.520 MHz	-15.210	00.000	28.58
980.640 MHz	-15.030	00.000	28.75
983.240 MHz	-14.930	00.000	28.88
984.220 MHz	-14.990	00.000	28.83
985.460 MHz	-14.880	00.000	28.95
987.200 MHz	-14.350	00.000	29.49
989.300 MHz	-15.310	00.000	28.55
989.600 MHz	-15.260	00.000	28.61
990.000 MHz	-03.890	00.000	39.97
990.400 MHz	-14.010	00.000	29.86
991.240 MHz	-15.030	00.000	28.85
993.680 MHz	-15.210	00.000	28.69
995.120 MHz	-15.310	00.000	28.60
996.080 MHz	-14.810	00.000	29.11



Company: Product Management Office, Air Warrior
Model Tested: OPC-M2
Report Number: 28380
Project Number: 13049
Test: RE102, Electric Field Emissions

D.L.S. Electronic Systems, Inc.

MIL-STD-461G RE102

1-18GHz Emissions (peak)

Customer - Booz Allen Hamilton
EUT - OPC-M2 Oxygen Monitor SN:05694
Antenna Position - EUT - Vertical
Limit - Fixed Wing External or Helicopters
Power/Mode - N/A
Engineer - TL
Notes - System Verification - 6dB Below Limit @ 17.5GHz

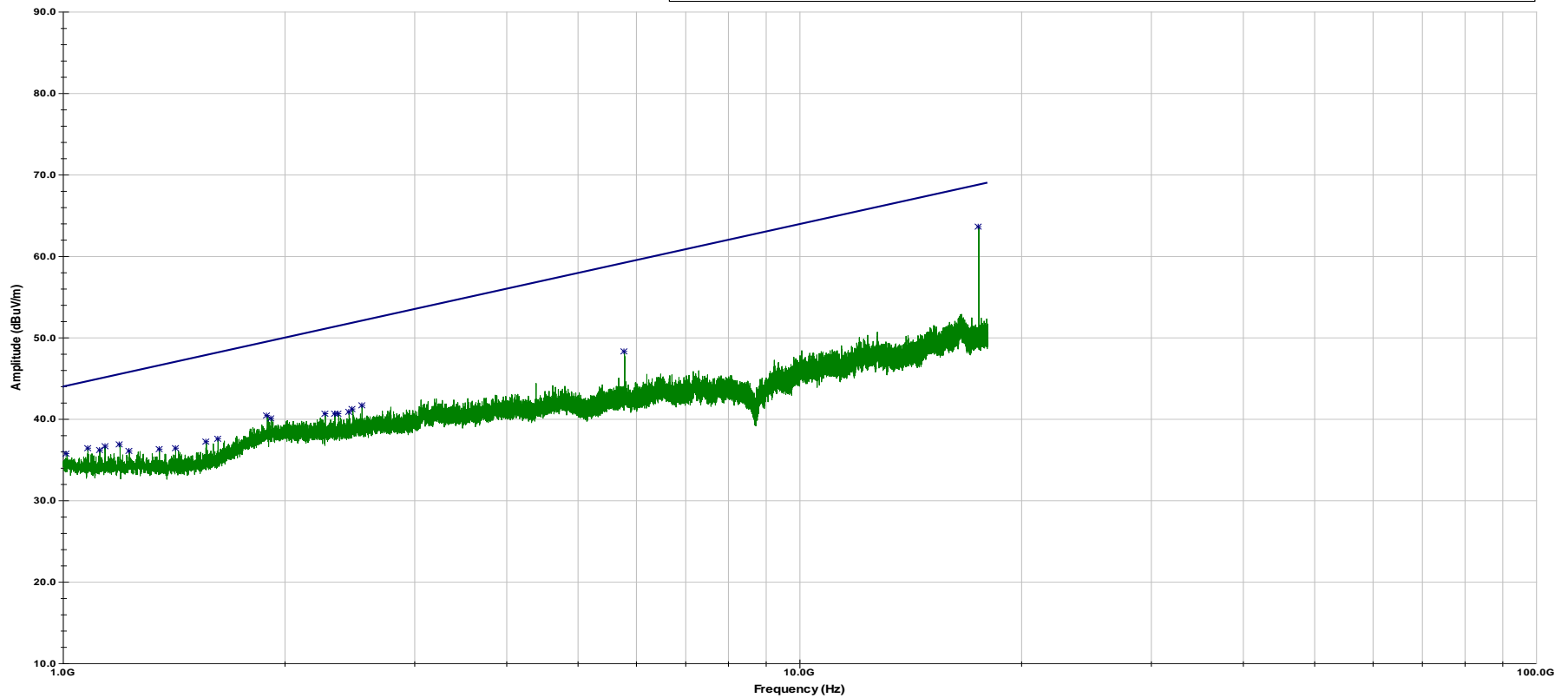

Last Data Update 10:42:18 AM, Tuesday, February 27, 2024

RE102 1-18GHz System Verification Scan



Company: Product Management Office, Air Warrior
 Model Tested: OPC-M2
 Report Number: 28380
 Project Number: 13049
 Test: RE102, Electric Field Emissions

10:42:18 AM

Tuesday, February
27, 2024

Frequency	Complying Emissions (dB below limit)	Excessive Emissions (dB exceeding limit)	Highest Emissions (amplitude in dBuV/m)
01.012 GHz	-08.360	00.000	35.70
01.080 GHz	-08.210	00.000	36.42
01.121 GHz	-08.740	00.000	36.21
01.140 GHz	-08.510	00.000	36.58
01.195 GHz	-08.610	00.000	36.89
01.230 GHz	-09.740	00.000	36.01
01.351 GHz	-10.300	00.000	36.26
01.421 GHz	-10.590	00.000	36.41
01.564 GHz	-10.610	00.000	37.22
01.622 GHz	-10.580	00.000	37.57
01.893 GHz	-09.130	00.000	40.35
01.919 GHz	-09.510	00.000	40.09
02.269 GHz	-10.440	00.000	40.61
02.337 GHz	-10.660	00.000	40.65
02.366 GHz	-10.830	00.000	40.59
02.444 GHz	-10.860	00.000	40.84
02.473 GHz	-10.590	00.000	41.21
02.545 GHz	-10.440	00.000	41.61
05.779 GHz	-10.900	00.000	48.25
17.500 GHz	-05.150	00.000	63.61



Company: Product Management Office, Air Warrior
Model Tested: OPC-M2
Report Number: 28380
Project Number: 13049
Test: RE102, Electric Field Emissions

MIL-STD-461G

RE102

RADIATED EMISSIONS

ELECTRIC FIELD

USING

OPC-M2 EMI SOF TEST PLAN REV B 1.19.24 WITH REDLINES

AMBIENT DATA



Company: Product Management Office, Air Warrior
Model Tested: OPC-M2
Report Number: 28380
Project Number: 13049
Test: RE102, Electric Field Emissions

D.L.S. Electronic Systems, Inc.

MIL-STD-461G RE102

10kHz-30MHz Emissions (peak)

Customer - Booz Allen Hamilton
EUT - OPC-M2 Oxygen Monitor SN:05694
Antenna Position - Center of EUT Boundary
Limit - Fixed Wing External or Helicopters
Power/Mode - N/A
Engineer - TL
Notes - Ambient - EUT OFF

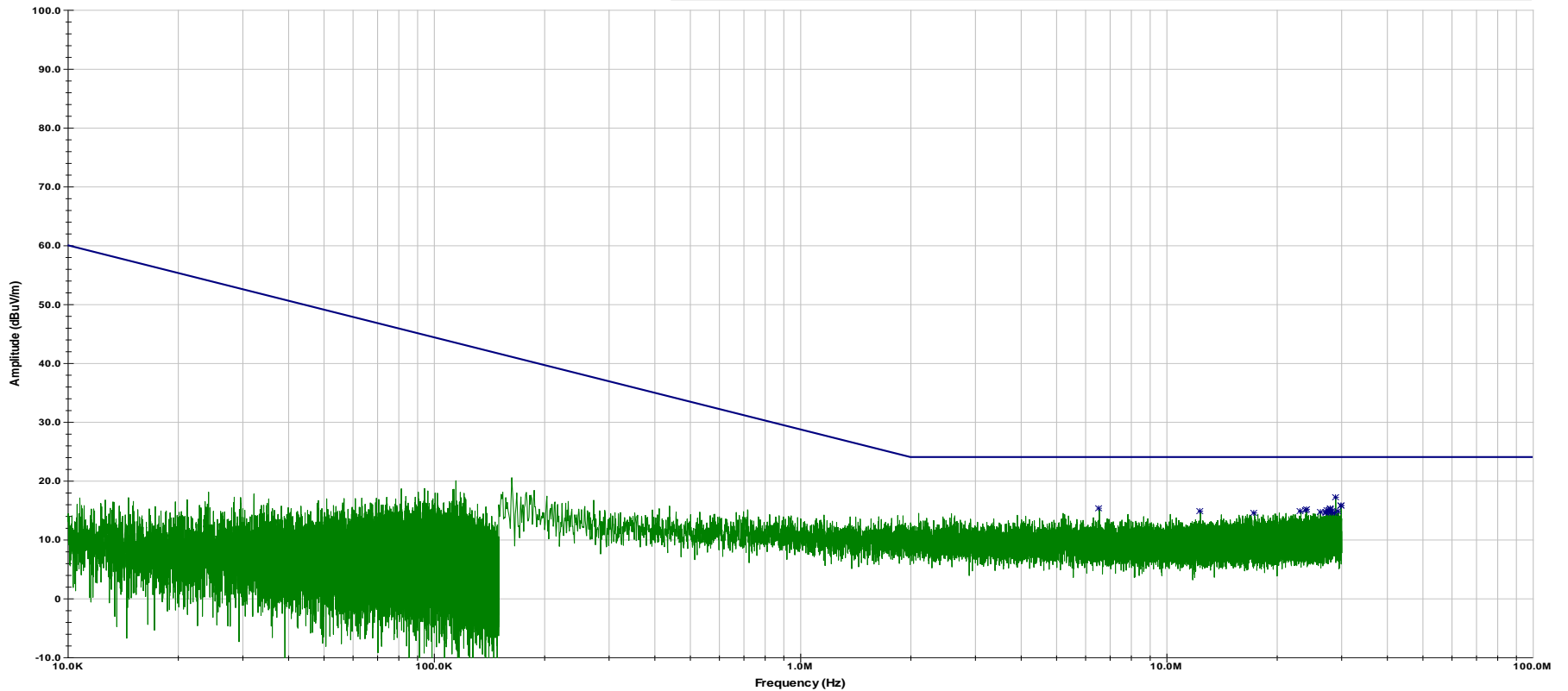

Last Data Update 12:14:39 PM, Monday, February 26, 2024

RE102 10kHz-30MHz Ambient Scan



Company: Product Management Office, Air Warrior
 Model Tested: OPC-M2
 Report Number: 28380
 Project Number: 13049
 Test: RE102, Electric Field Emissions

12:14:39 PM

Monday, February 26,
2024

Frequency	Complying Emissions (dB below limit)	Excessive Emissions (dB exceeding limit)	Highest Emissions (amplitude in dBuV/m)
06.542 MHz	-08.770	00.000	15.23
12.351 MHz	-09.220	00.000	14.78
17.352 MHz	-09.400	00.000	14.60
23.223 MHz	-09.110	00.000	14.89
24.023 MHz	-09.070	00.000	14.93
24.117 MHz	-08.820	00.000	15.18
26.270 MHz	-09.350	00.000	14.65
27.211 MHz	-09.300	00.000	14.70
27.323 MHz	-09.410	00.000	14.59
27.366 MHz	-09.070	00.000	14.93
27.881 MHz	-09.060	00.000	14.94
28.069 MHz	-09.360	00.000	14.64
28.080 MHz	-08.890	00.000	15.11
28.081 MHz	-08.730	00.000	15.27
28.273 MHz	-09.300	00.000	14.70
28.696 MHz	-09.430	00.000	14.57
28.900 MHz	-06.820	00.000	17.18
29.448 MHz	-09.230	00.000	14.77
29.933 MHz	-08.210	00.000	15.79
29.946 MHz	-08.240	00.000	15.76



Company: Product Management Office, Air Warrior
Model Tested: OPC-M2
Report Number: 28380
Project Number: 13049
Test: RE102, Electric Field Emissions

D.L.S. Electronic Systems, Inc.

MIL-STD-461G RE102

30-200MHz Emissions (peak)

Customer - Booz Allen Hamilton
EUT - OPC-M2 Oxygen Monitor SN:05694
Antenna Position - Center of EUT Boundary- Horizontal
Limit - Fixed Wing External or Helicopters
Power/Mode - N/A
Engineer - TL
Notes - Ambient - EUT OFF

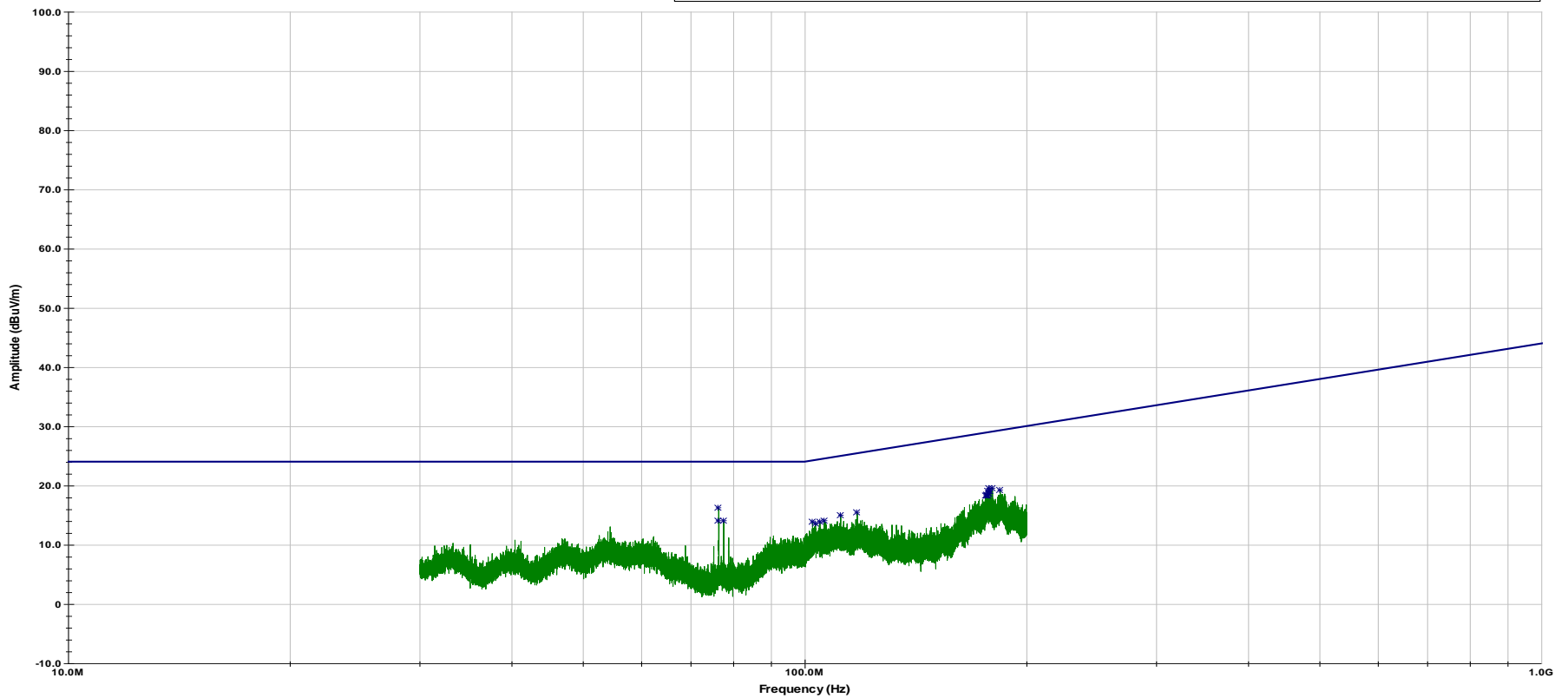

Last Data Update 02:18:43 PM, Monday, February 26, 2024

RE102 30-200MHz Horizontal Ambient Scan



Company: Product Management Office, Air Warrior
Model Tested: OPC-M2
Report Number: 28380
Project Number: 13049
Test: RE102, Electric Field Emissions

02:18:43 PM

Monday, February 26,
2024

Frequency	Complying Emissions (dB below limit)	Excessive Emissions (dB exceeding limit)	Highest Emissions (amplitude in dBuV/m)
76.357 MHz	-07.790	00.000	16.21
76.403 MHz	-10.030	00.000	13.97
77.536 MHz	-09.970	00.000	14.03
102.380 MHz	-10.250	00.000	13.95
103.310 MHz	-10.700	00.000	13.58
104.780 MHz	-10.510	00.000	13.89
106.220 MHz	-10.490	00.000	14.04
111.780 MHz	-09.940	00.000	15.03
117.740 MHz	-09.960	00.000	15.45
176.100 MHz	-10.670	00.000	18.24
176.720 MHz	-10.510	00.000	18.42
176.860 MHz	-10.710	00.000	18.23
177.000 MHz	-10.630	00.000	18.32
177.140 MHz	-09.920	00.000	19.03
177.700 MHz	-10.400	00.000	18.58
177.730 MHz	-09.510	00.000	19.47
177.780 MHz	-10.450	00.000	18.54
178.760 MHz	-09.980	00.000	19.06
179.650 MHz	-09.480	00.000	19.59
184.120 MHz	-10.110	00.000	19.18



Company: Product Management Office, Air Warrior
Model Tested: OPC-M2
Report Number: 28380
Project Number: 13049
Test: RE102, Electric Field Emissions

D.L.S. Electronic Systems, Inc.

MIL-STD-461G RE102

30-200MHz Emissions (peak)

Customer - Booz Allen Hamilton
EUT - OPC-M2 Oxygen Monitor SN:05694
Antenna Position - Center of EUT Boundary- Vertical
Limit - Fixed Wing External or Helicopters
Power/Mode - N/A
Engineer - TL
Notes - Ambient - EUT OFF

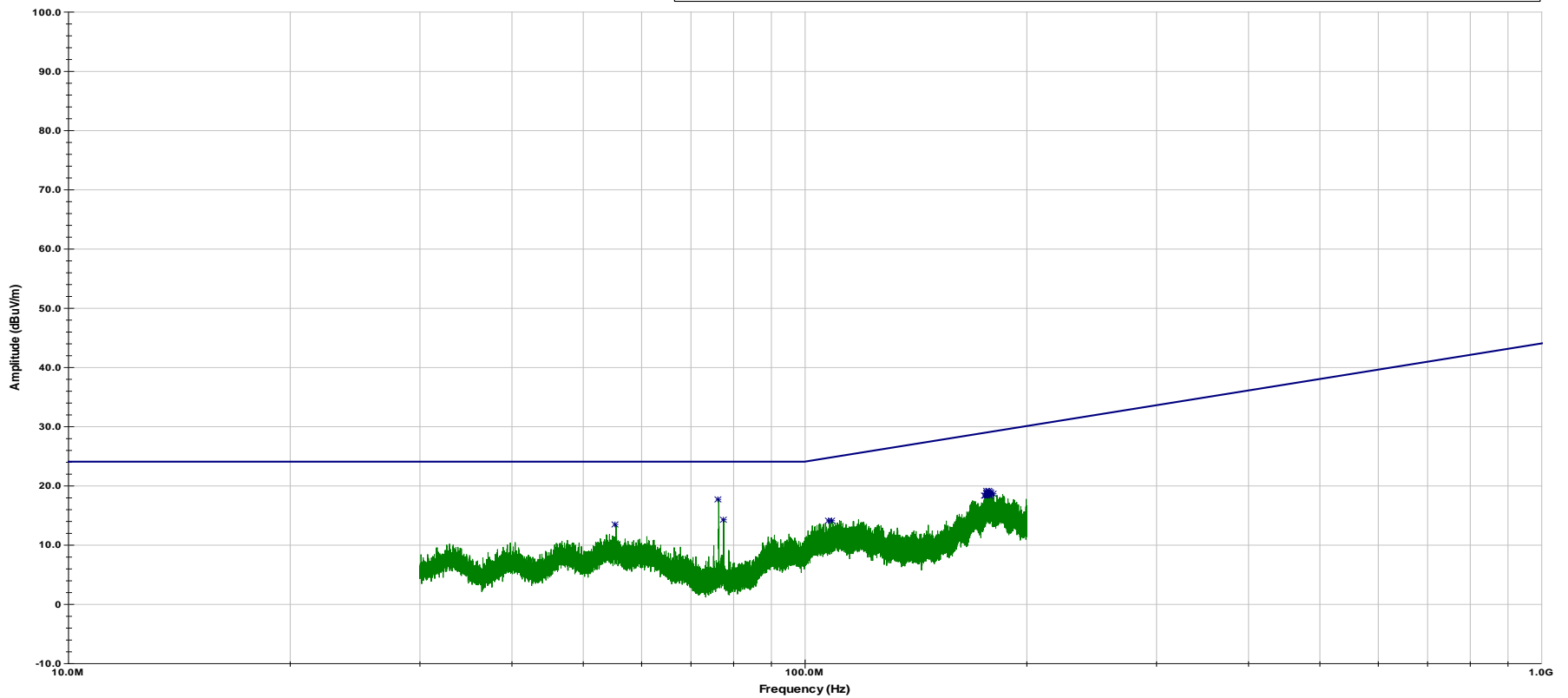

Last Data Update 02:11:22 PM, Monday, February 26, 2024

RE102 30-200MHz Vertical Ambient Scan



Company: Product Management Office, Air Warrior
Model Tested: OPC-M2
Report Number: 28380
Project Number: 13049
Test: RE102, Electric Field Emissions

02:11:22 PM

Monday, February 26,
2024

Frequency	Complying Emissions (dB below limit)	Excessive Emissions (dB exceeding limit)	Highest Emissions (amplitude in dBuV/m)
55.387 MHz	-10.640	00.000	13.36
76.360 MHz	-06.340	00.000	17.66
77.543 MHz	-09.840	00.000	14.16
107.920 MHz	-10.600	00.000	14.06
108.950 MHz	-10.640	00.000	14.11
175.510 MHz	-10.680	00.000	18.20
175.830 MHz	-10.640	00.000	18.25
176.350 MHz	-10.310	00.000	18.61
176.690 MHz	-09.930	00.000	19.00
176.790 MHz	-10.110	00.000	18.83
177.280 MHz	-10.180	00.000	18.78
177.830 MHz	-09.970	00.000	19.02
177.930 MHz	-10.410	00.000	18.59
177.950 MHz	-10.600	00.000	18.39
178.150 MHz	-10.530	00.000	18.47
178.270 MHz	-10.120	00.000	18.89
178.330 MHz	-10.700	00.000	18.31
178.670 MHz	-10.480	00.000	18.55
178.960 MHz	-10.340	00.000	18.70
180.380 MHz	-10.460	00.000	18.65



Company: Product Management Office, Air Warrior
Model Tested: OPC-M2
Report Number: 28380
Project Number: 13049
Test: RE102, Electric Field Emissions

D.L.S. Electronic Systems, Inc.

MIL-STD-461G RE102

200-1000MHz Emissions (peak)

Customer - Booz Allen Hamilton
EUT - OPC-M2 Oxygen Monitor SN:05694
Antenna Position - EUT - Horizontal
Limit - Fixed Wing External or Helicopters
Power/Mode - N/A
Engineer - TL
Notes - Ambient - EUT OFF

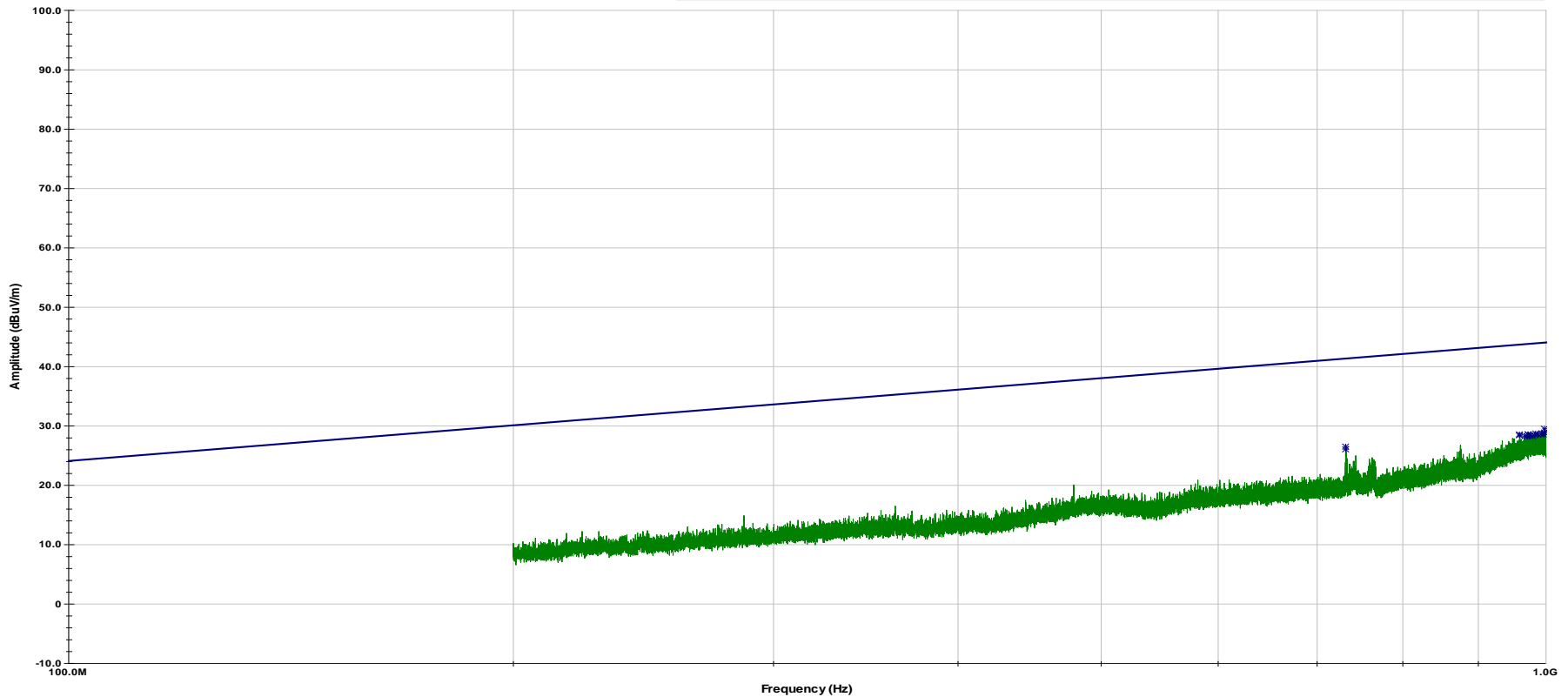

Last Data Update 04:15:19 PM, Monday, February 26, 2024

RE102 200-1000MHz Horizontal Ambient Scan



Company: Product Management Office, Air Warrior
 Model Tested: OPC-M2
 Report Number: 28380
 Project Number: 13049
 Test: RE102, Electric Field Emissions

04:15:19 PM

Monday, February 26,
2024

Frequency	Complying Emissions (dB below limit)	Excessive Emissions (dB exceeding limit)	Highest Emissions (amplitude in dBuV/m)
732.540 MHz	-15.330	00.000	25.92
732.740 MHz	-14.870	00.000	26.39
959.920 MHz	-15.160	00.000	28.44
960.220 MHz	-15.350	00.000	28.25
967.960 MHz	-15.470	00.000	28.20
971.100 MHz	-15.480	00.000	28.22
971.300 MHz	-15.550	00.000	28.15
973.220 MHz	-15.190	00.000	28.53
973.700 MHz	-15.180	00.000	28.54
975.720 MHz	-15.460	00.000	28.28
977.300 MHz	-15.470	00.000	28.28
979.300 MHz	-15.530	00.000	28.24
983.880 MHz	-15.430	00.000	28.39
985.120 MHz	-15.090	00.000	28.74
987.580 MHz	-15.340	00.000	28.51
992.960 MHz	-15.340	00.000	28.55
995.500 MHz	-15.260	00.000	28.66
996.520 MHz	-15.420	00.000	28.50
997.700 MHz	-14.520	00.000	29.42
999.020 MHz	-15.130	00.000	28.82



Company: Product Management Office, Air Warrior
Model Tested: OPC-M2
Report Number: 28380
Project Number: 13049
Test: RE102, Electric Field Emissions

D.L.S. Electronic Systems, Inc.

MIL-STD-461G RE102

200-1000MHz Emissions (peak)

Customer - Booz Allen Hamilton
EUT - OPC-M2 Oxygen Monitor SN:05694
Antenna Position - EUT - Vertical
Limit - Fixed Wing External or Helicopters
Power/Mode - N/A
Engineer - TL
Notes - Ambient - EUT OFF

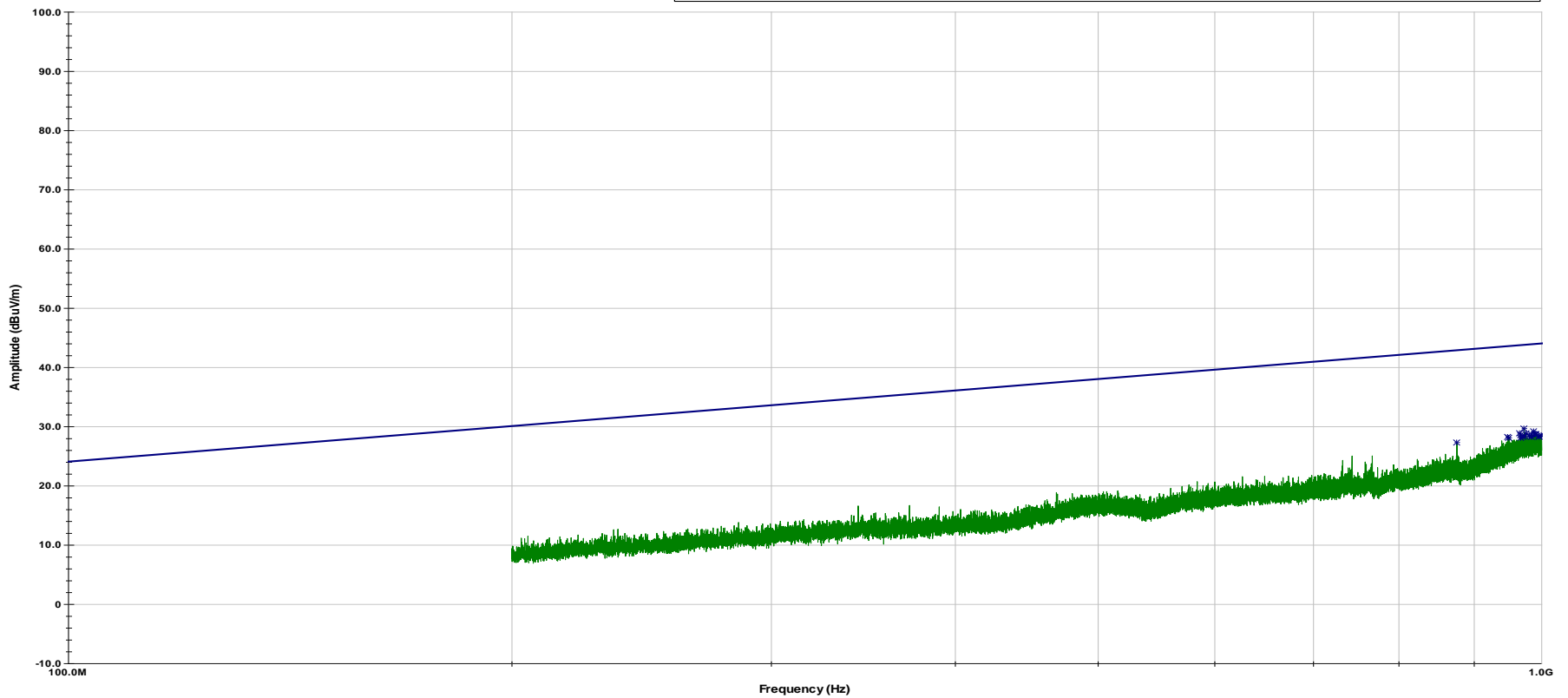

Last Data Update 03:41:18 PM, Monday, February 26, 2024

RE102 200-1000MHz Vertical Ambient Scan



Company: Product Management Office, Air Warrior
 Model Tested: OPC-M2
 Report Number: 28380
 Project Number: 13049
 Test: RE102, Electric Field Emissions

03:41:18 PM

Monday, February 26,
2024

Frequency	Complying Emissions (dB below limit)	Excessive Emissions (dB exceeding limit)	Highest Emissions (amplitude in dBuV/m)
875.900 MHz	-15.580	00.000	27.22
948.900 MHz	-15.390	00.000	28.11
950.400 MHz	-15.520	00.000	27.99
967.000 MHz	-14.870	00.000	28.80
968.200 MHz	-15.220	00.000	28.45
968.680 MHz	-15.620	00.000	28.06
970.940 MHz	-15.560	00.000	28.14
973.140 MHz	-14.140	00.000	29.58
975.260 MHz	-15.480	00.000	28.26
976.100 MHz	-14.960	00.000	28.78
981.300 MHz	-15.490	00.000	28.30
984.320 MHz	-15.230	00.000	28.58
984.780 MHz	-15.710	00.000	28.11
987.700 MHz	-14.660	00.000	29.18
989.540 MHz	-15.280	00.000	28.58
991.540 MHz	-15.290	00.000	28.59
991.780 MHz	-15.170	00.000	28.72
996.340 MHz	-15.540	00.000	28.38
997.160 MHz	-15.700	00.000	28.23
999.180 MHz	-15.440	00.000	28.50



Company: Product Management Office, Air Warrior
Model Tested: OPC-M2
Report Number: 28380
Project Number: 13049
Test: RE102, Electric Field Emissions

D.L.S. Electronic Systems, Inc.

MIL-STD-461G RE102

1-18GHz Emissions (peak)

Customer - Booz Allen Hamilton
EUT - OPC-M2 Oxygen Monitor SN:05694
Antenna Position - EUT - Horizontal
Limit - Fixed Wing External or Helicopters
Power/Mode - N/A
Engineer - TL
Notes - Ambient - EUT OFF

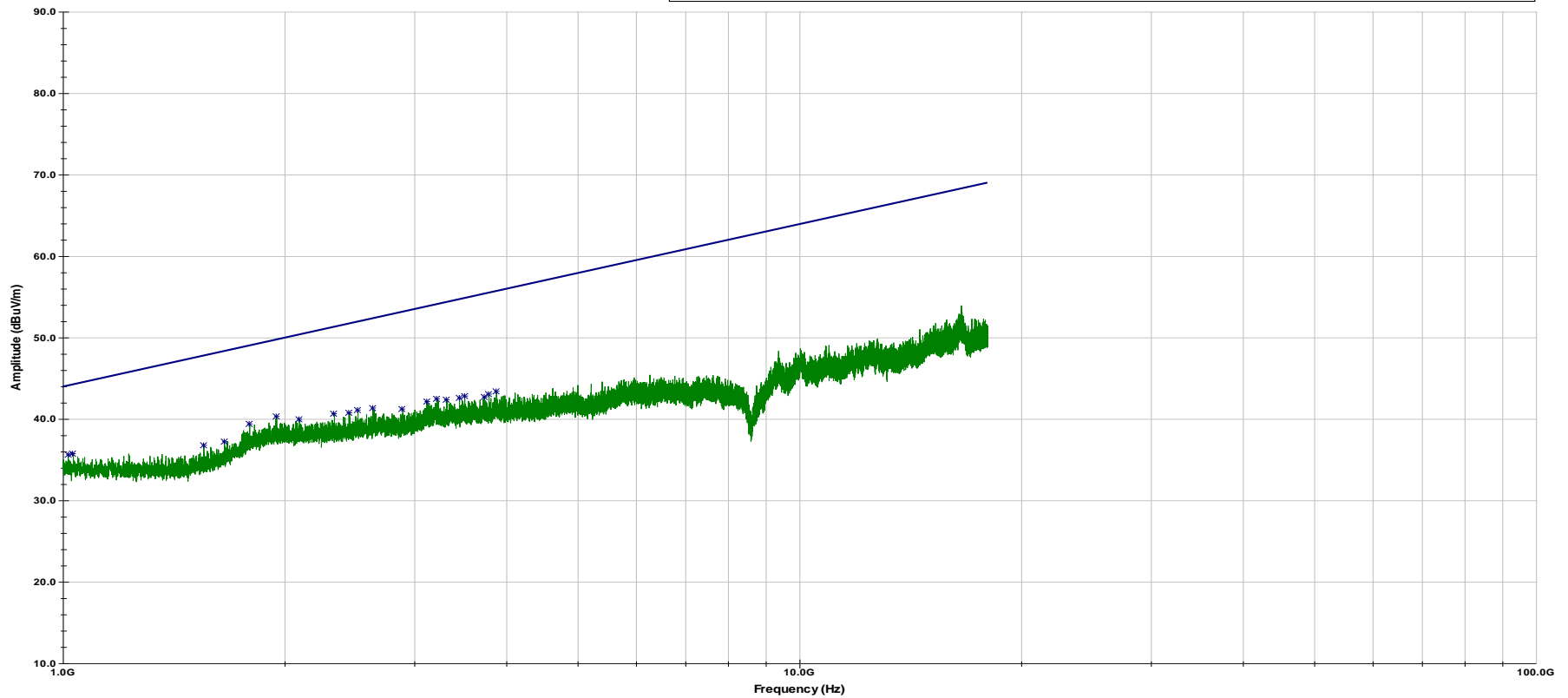

Last Data Update 12:13:36 PM, Tuesday, February 27, 2024

RE102 1-18GHz Horizontal Ambient Scan



Company: Product Management Office, Air Warrior
Model Tested: OPC-M2
Report Number: 28380
Project Number: 13049
Test: RE102, Electric Field Emissions

12:13:36 PM

Tuesday, February
27, 2024

Frequency	Complying Emissions (dB below limit)	Excessive Emissions (dB exceeding limit)	Highest Emissions (amplitude in dBuV/m)
01.016 GHz	-08.540	00.000	35.55
01.032 GHz	-08.550	00.000	35.68
01.552 GHz	-11.000	00.000	36.77
01.655 GHz	-11.090	00.000	37.23
01.791 GHz	-09.680	00.000	39.32
01.948 GHz	-09.470	00.000	40.26
02.093 GHz	-10.450	00.000	39.90
02.335 GHz	-10.730	00.000	40.58
02.447 GHz	-10.980	00.000	40.73
02.513 GHz	-10.910	00.000	41.03
02.632 GHz	-11.080	00.000	41.26
02.891 GHz	-11.920	00.000	41.23
03.117 GHz	-11.690	00.000	42.11
03.221 GHz	-11.640	00.000	42.45
03.318 GHz	-12.050	00.000	42.29
03.452 GHz	-12.150	00.000	42.54
03.508 GHz	-12.020	00.000	42.81
03.729 GHz	-12.680	00.000	42.68
03.785 GHz	-12.430	00.000	43.06
03.875 GHz	-12.350	00.000	43.34



Company: Product Management Office, Air Warrior
Model Tested: OPC-M2
Report Number: 28380
Project Number: 13049
Test: RE102, Electric Field Emissions

D.L.S. Electronic Systems, Inc.

MIL-STD-461G RE102

1-18GHz Emissions (peak)

Customer - Booz Allen Hamilton
EUT - OPC-M2 Oxygen Monitor SN:05694
Antenna Position - EUT - Vertical
Limit - Fixed Wing External or Helicopters
Power/Mode - N/A
Engineer - TL
Notes - Ambient - EUT OFF

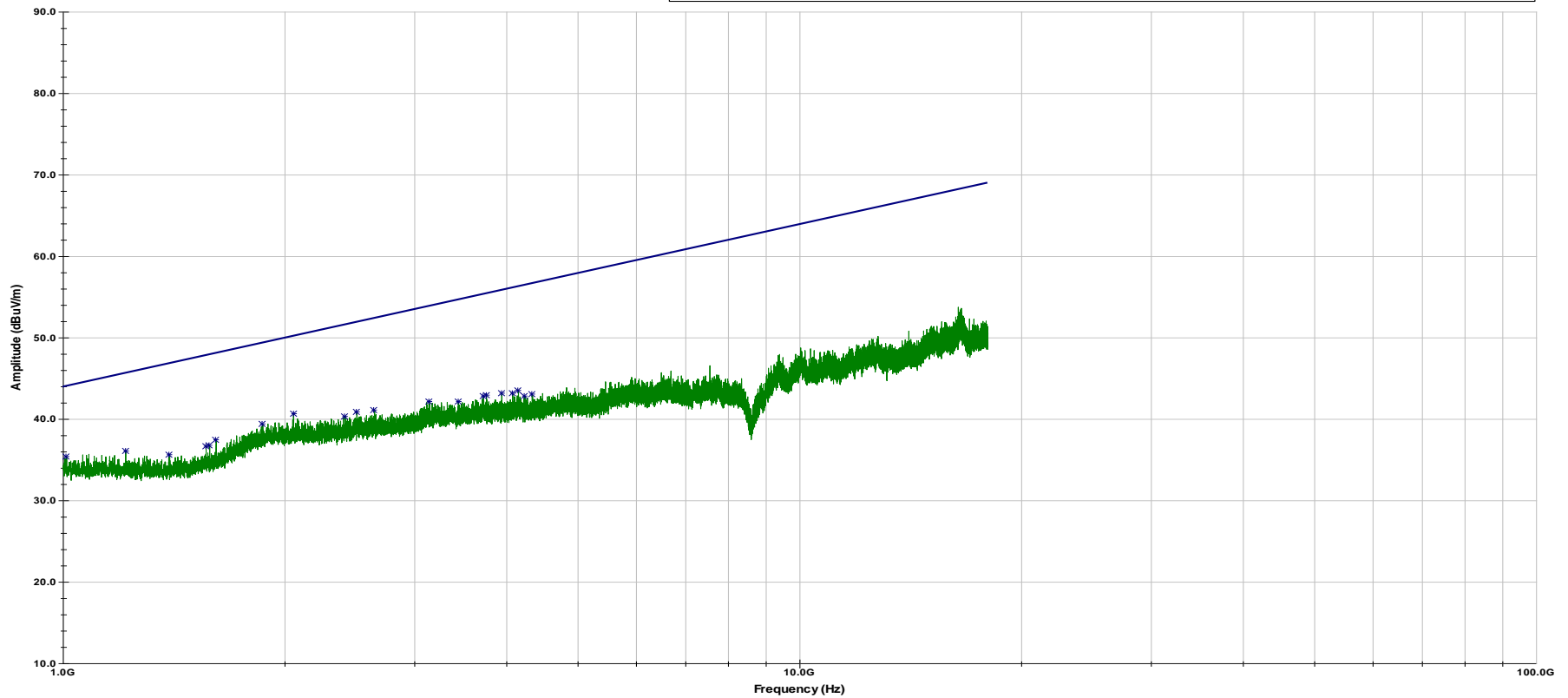

Last Data Update 11:56:05 AM, Tuesday, February 27, 2024

RE102 1-18GHz Vertical Ambient Scan



Company: Product Management Office, Air Warrior
 Model Tested: OPC-M2
 Report Number: 28380
 Project Number: 13049
 Test: RE102, Electric Field Emissions

11:56:05 AM

Tuesday, February
27, 2024

Frequency	Complying Emissions (dB below limit)	Excessive Emissions (dB exceeding limit)	Highest Emissions (amplitude in dBuV/m)
01.011 GHz	-08.650	00.000	35.40
01.216 GHz	-09.580	00.000	36.06
01.395 GHz	-11.190	00.000	35.64
01.563 GHz	-11.210	00.000	36.62
01.581 GHz	-11.170	00.000	36.75
01.613 GHz	-10.680	00.000	37.42
01.866 GHz	-10.030	00.000	39.33
02.054 GHz	-09.630	00.000	40.57
02.415 GHz	-11.260	00.000	40.33
02.504 GHz	-11.040	00.000	40.87
02.646 GHz	-11.330	00.000	41.05
03.137 GHz	-11.740	00.000	42.12
03.439 GHz	-12.600	00.000	42.06
03.722 GHz	-12.560	00.000	42.78
03.754 GHz	-12.490	00.000	42.92
03.939 GHz	-12.740	00.000	43.10
04.075 GHz	-13.040	00.000	43.09
04.149 GHz	-12.800	00.000	43.48
04.239 GHz	-13.660	00.000	42.81
04.332 GHz	-13.600	00.000	43.05



Company: Product Management Office, Air Warrior
Model Tested: OPC-M2
Report Number: 28380
Project Number: 13049
Test: RS103, Electric Field Susceptibility

MIL-STD-461G

RS103

RADIATED SUSCEPTIBILITY

ELECTRIC FIELD

USING

OPC-M2 EMI SOF TEST PLAN REV B 1.19.24 WITH REDLINES



Company: Product Management Office, Air Warrior
 Model Tested: OPC-M2
 Report Number: 28380
 Project Number: 13049
 Test: RS103, Electric Field Susceptibility

1.0 TEST DATES

February 27-March 4, 2024

2.0 EQUIPMENT UNDER TEST

Description: Oxygen pulse controller
 Quantity: One (1)
 Model Tested: OPC-M2
 Serial Number: 05694

3.0 TEST SPECIFICATIONS

The Oxygen pulse controller was subjected to Electric Field Radiation Susceptibility, over the frequency range from 2 MHz - 10000 MHz, and also the general requirements of MIL-STD-461G RS103, per OPC-M2 EMI SOF Test Plan Rev B 1.19.24 with Redlines.

There shall be no physical or electrical failures that prevent the EUT from being operated per customer's test requirements; the EUT shall meet inspection requirements of customer QTP.

4.0 LIMITS

The Oxygen pulse controller was tested to the following requirements of MIL-STD-461G RS103 Electric Field Radiation Susceptibility, per OPC-M2 EMI SOF Test Plan Rev B 1.19.24 with Redlines as shown below:

MIL-STD-461G, TABLE III. Susceptibility scanning.

Frequency Range	Analog Scans / Maximum Scan Rates	Stepped Scans / Maximum Step Size
2 MHz – 30 MHz	0.00667 f _o /sec	0.01 f _o
30 MHz - 1 GHz	0.00333 f _o /sec	0.005 f _o
1 GHz - 40 GHz	0.00167 f _o /sec	0.0025 f _o



Company: Product Management Office, Air Warrior
Model Tested: OPC-M2
Report Number: 28380
Project Number: 13049
Test: RS103, Electric Field Susceptibility

5.0 RESULTS

The Oxygen pulse controller **was tested to** the following conditions of MIL-STD-461G RS103 Electric Field Radiation Susceptibility, per OPC-M2 EMI SOF Test Plan Rev B 1.19.24 with Redlines.

Lab used: R

Frequency Range: 2 MHz - 10000 MHz

Mode of Operation:

Test Mode

Levels:

The EUT was tested in the frequency range 2 MHz - 10000 MHz with levels 200V.

Summary:

The EUT showed severe functional issues between 827-1000MHz in the Horizontal polarization. At some point in the 900-1000MHz range, the EUT did become unresponsive completely without recovery after RF exposure was removed. The EUT returned to normal operation after cycling power. The test was then continued above 1GHz.

At some points during the test, the oxygen flow was seen to deviate from typical values. These events were noted on the plots with a frequency label.

The plots at the end of this section are derived from the log files from the oxygen meter. The Y-axis of the data is in LPM (liters per minute).

Plots and tabular data can be viewed at the end of this section.



Company: Product Management Office, Air Warrior
 Model Tested: OPC-M2
 Report Number: 28380
 Project Number: 13049
 Test: RS103, Electric Field Susceptibility

TEST INSTRUMENTATION

TABLE 1

Description	Manufacturer	Model Number	Serial Number	Range	Firmware/ Software Version	Cal On	Cal Due Dates
Generator, Signal	Rohde & Schwarz	SML03	103785	9kHz-3.3GHz	2.51.15:5/14/2008	1/17/2024	1/16/2025
Probe, RF Field	Amplifier Research	FP2000	22924	10kHz-1GHz	N/A	10/5/2023	10/4/2024
Probe, RF Field	Amplifier Research	FP5080	22987	80MHz-40GHz	N/A	2/26/2024	2/25/2025
Probe, RF Field	Amplifier Research	FP5000	22842	10kHz-1000MHz	N/A	12/18/2023	12/17/2024
Signal Generator	Rohde & Schwarz	SMB100A	178704	100 kHz to 40 GHz	3.01.203.51:2/26/2016	4/17/2023	4/16/2024

All primary equipment is calibrated against known reference standards with a verified traceable path to NIST.



Company: Product Management Office, Air Warrior
 Model Tested: OPC-M2
 Report Number: 28380
 Project Number: 13049
 Test: RS103, Electric Field Susceptibility

TEST EQUIPMENT

TABLE 2

Description	Manufacturer	Model Number	Serial Number	Range	Firmware/ Software Version
Amplifier, RF, Power	Amplifier Research	200T2G2AM4	309786	2.5G-7.5GHz	N/A
Amplifier, RF, Power	Amplifier Research	1000W1000M7	22243	100MHz-1000MHz	N/A
Amplifier, RF, Power	PRANA	DP5000	2178	10kHz-250MHz	N/A
Amplifier, RF, Power	PRANA	SU300	1711-2179	1GHz-2.5GHz	N/A
Amplifier, RF, Power	Amplifier Research	200T8G18A	301107	7.5GHz-18GHz	N/A
Antenna, Biconical	TDK Lambda (Formerly EMS)	HPBA-2510	131123	20-200MHz	N/A
Antenna, E-Field	Amplifier Research	AT5000	28313	10kHz-100MHz	N/A
Antenna, Horn	Amplifier Research	AT4002A	301759	.8GHz-5GHz	N/A
Antenna, Horn	Amplifier Research	AT4000	22305	200MHz-1000MHz	N/A
Antenna, Horn	Amplifier Research	AT4003	301597	4GHz-8GHz	N/A
Antenna, Horn	Amplifier Research	AT4004	29282	8GHz-18GHz	N/A
Antenna, Log Periodic	Amplifier Research	AT1230	23709	80MHz-230MHz	N/A
Antenna Tripod	EMCO	N/A	N/A	N/A	N/A
Monitor, RF Field	Amplifier Research	FM5004	302153	N/A	5.4:7/31/2007

The above test equipment is verified upon use.



Company: Product Management Office, Air Warrior
Model Tested: OPC-M2
Report Number: 28380
Project Number: 13049
Test: RS103, Electric Field Susceptibility

MIL-STD-461G

RS103

RADIATED SUSCEPTIBILITY

ELECTRIC FIELD

USING

OPC-M2 EMI SOF TEST PLAN REV B 1.19.24 WITH REDLINES

TEST SETUP PHOTOS



Company: Product Management Office, Air Warrior
Model Tested: OPC-M2
Report Number: 28380
Project Number: 13049
Test: RS103, Electric Field Susceptibility

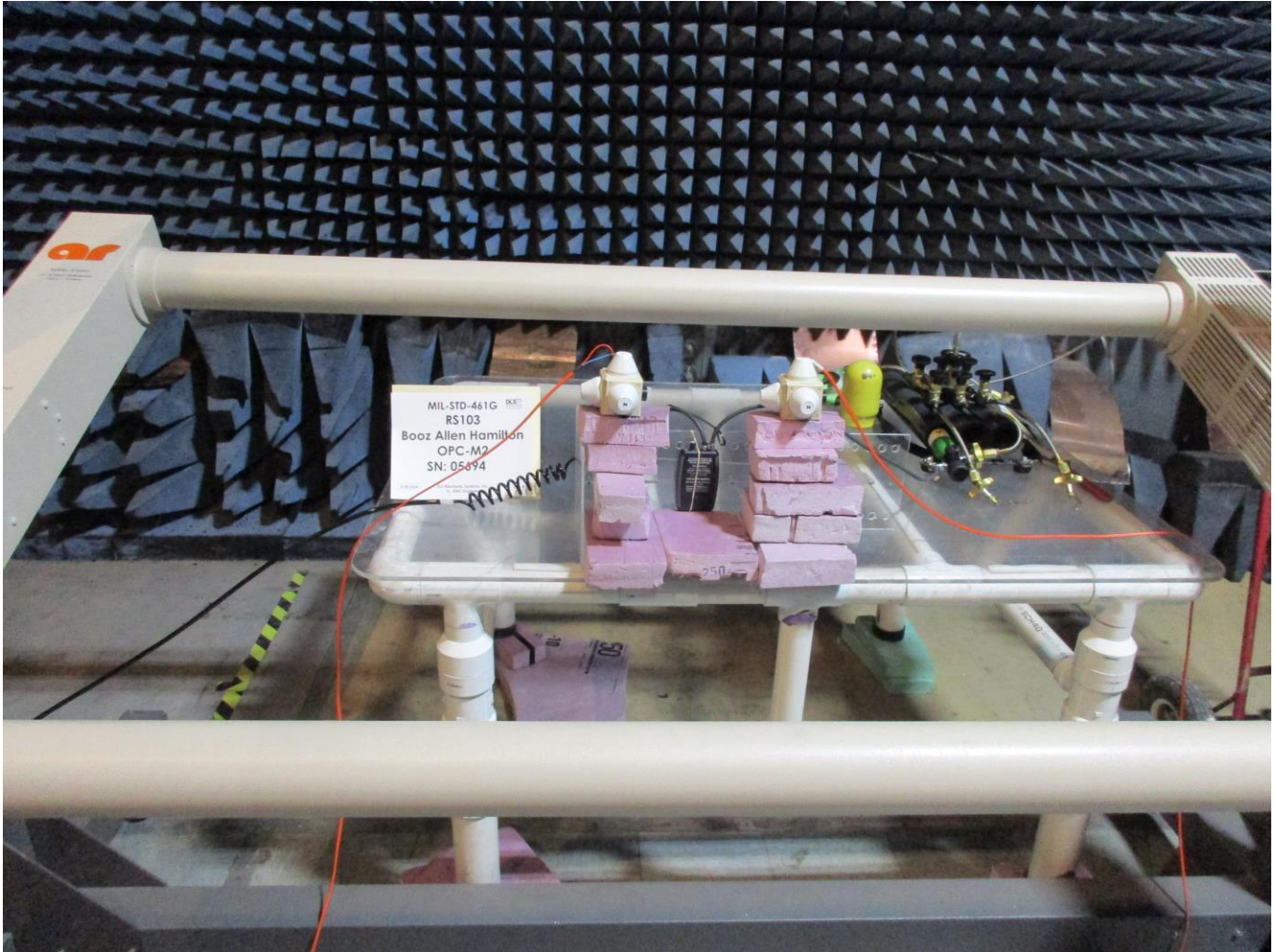

RS103 2-30MHz Test



Company: Product Management Office, Air Warrior
Model Tested: OPC-M2
Report Number: 28380
Project Number: 13049
Test: RS103, Electric Field Susceptibility

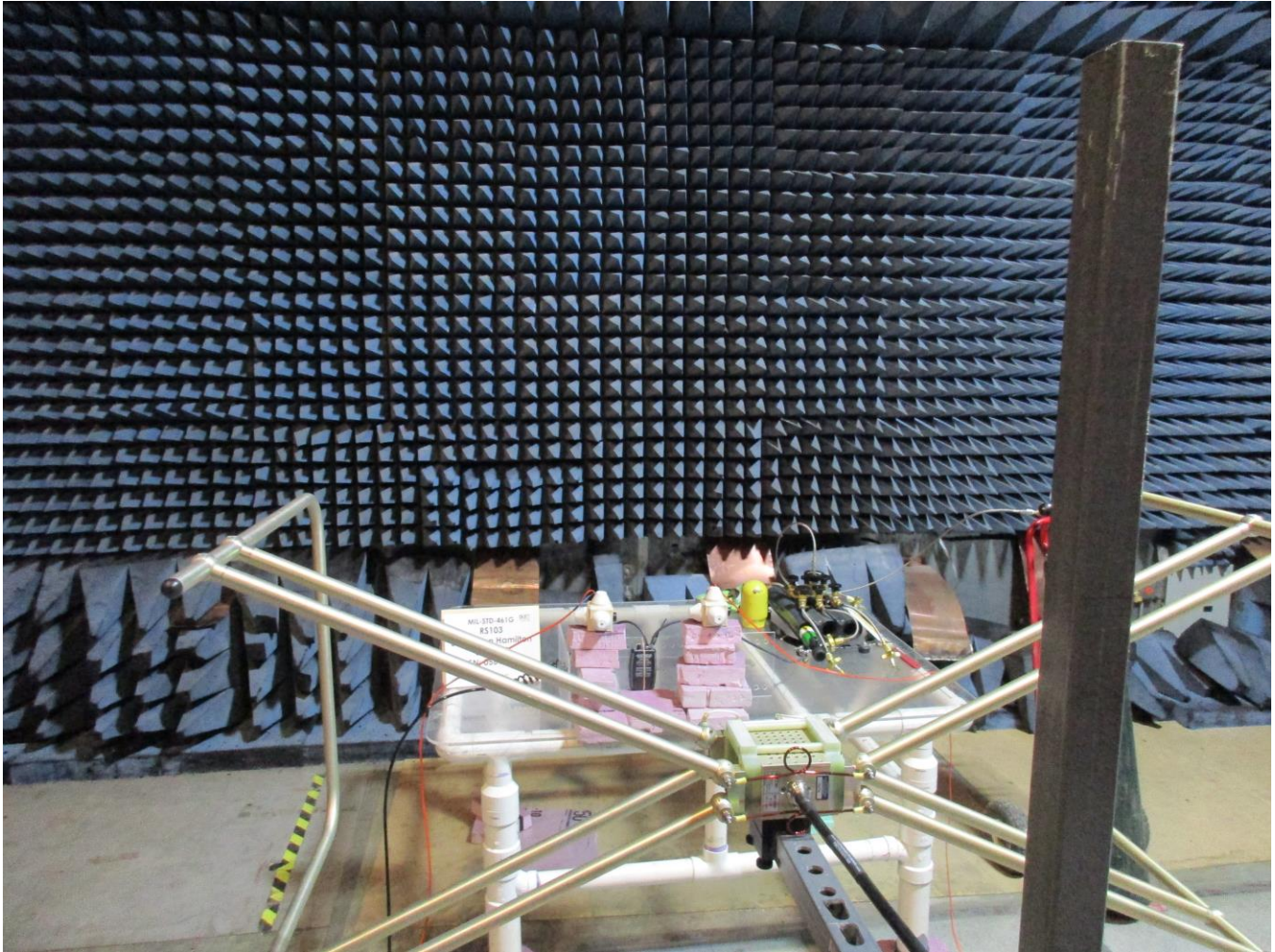

RS103 30-80MHz Horizontal Test



Company: Product Management Office, Air Warrior
Model Tested: OPC-M2
Report Number: 28380
Project Number: 13049
Test: RS103, Electric Field Susceptibility

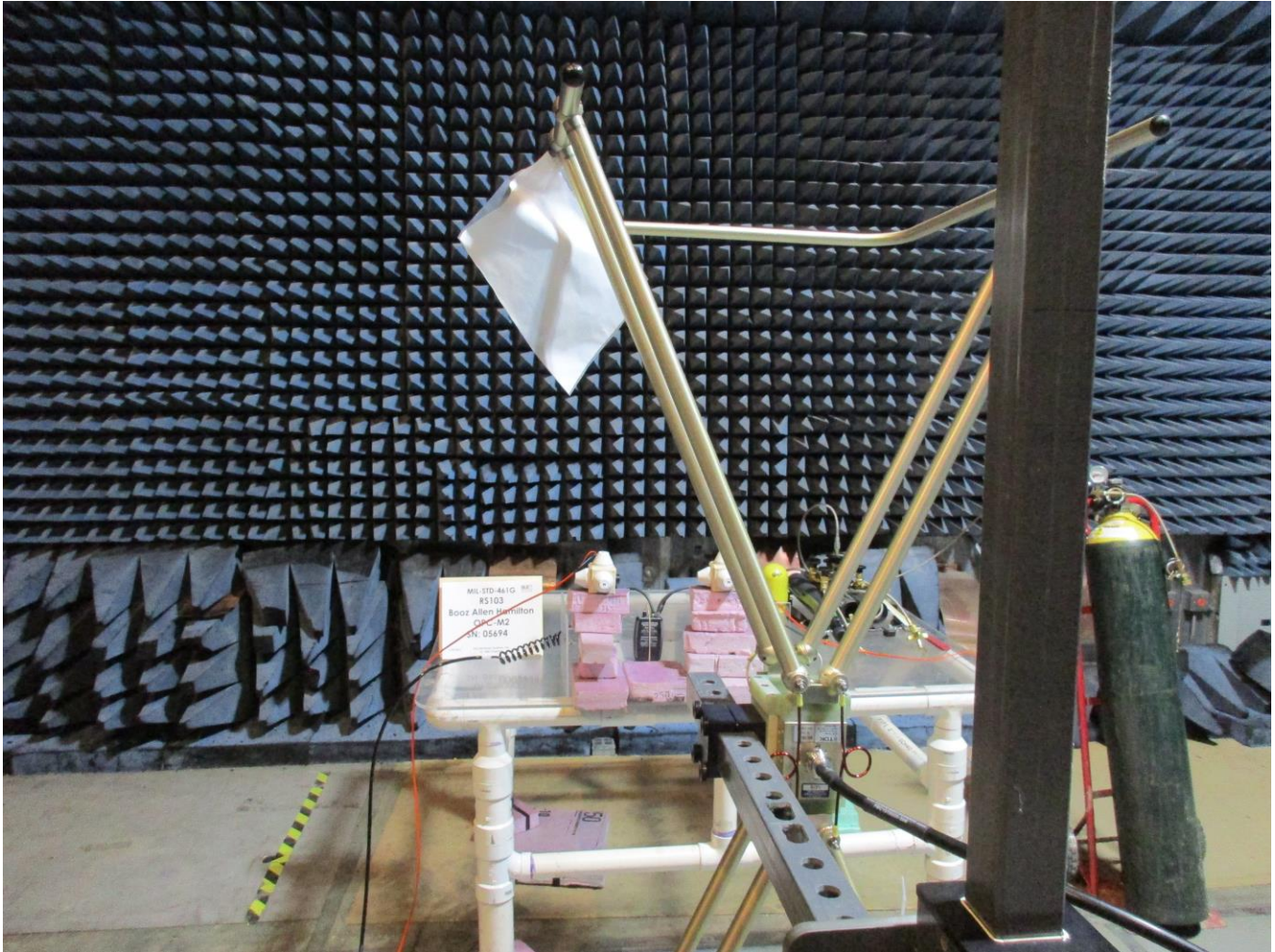

RS103 30-80MHz Vertical Test



Company: Product Management Office, Air Warrior
Model Tested: OPC-M2
Report Number: 28380
Project Number: 13049
Test: RS103, Electric Field Susceptibility

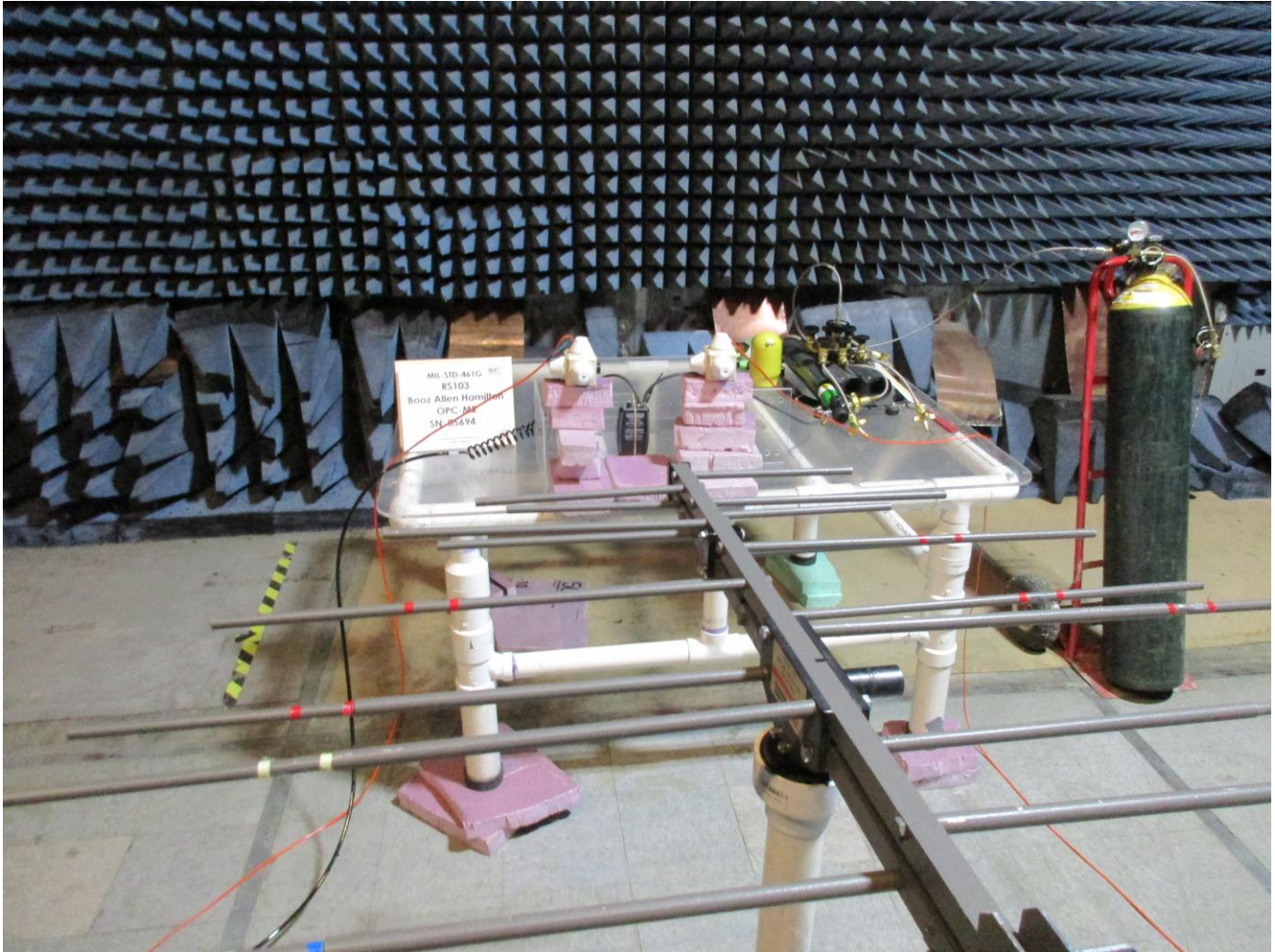

RS103 80-200MHz Horizontal Test



Company: Product Management Office, Air Warrior
Model Tested: OPC-M2
Report Number: 28380
Project Number: 13049
Test: RS103, Electric Field Susceptibility

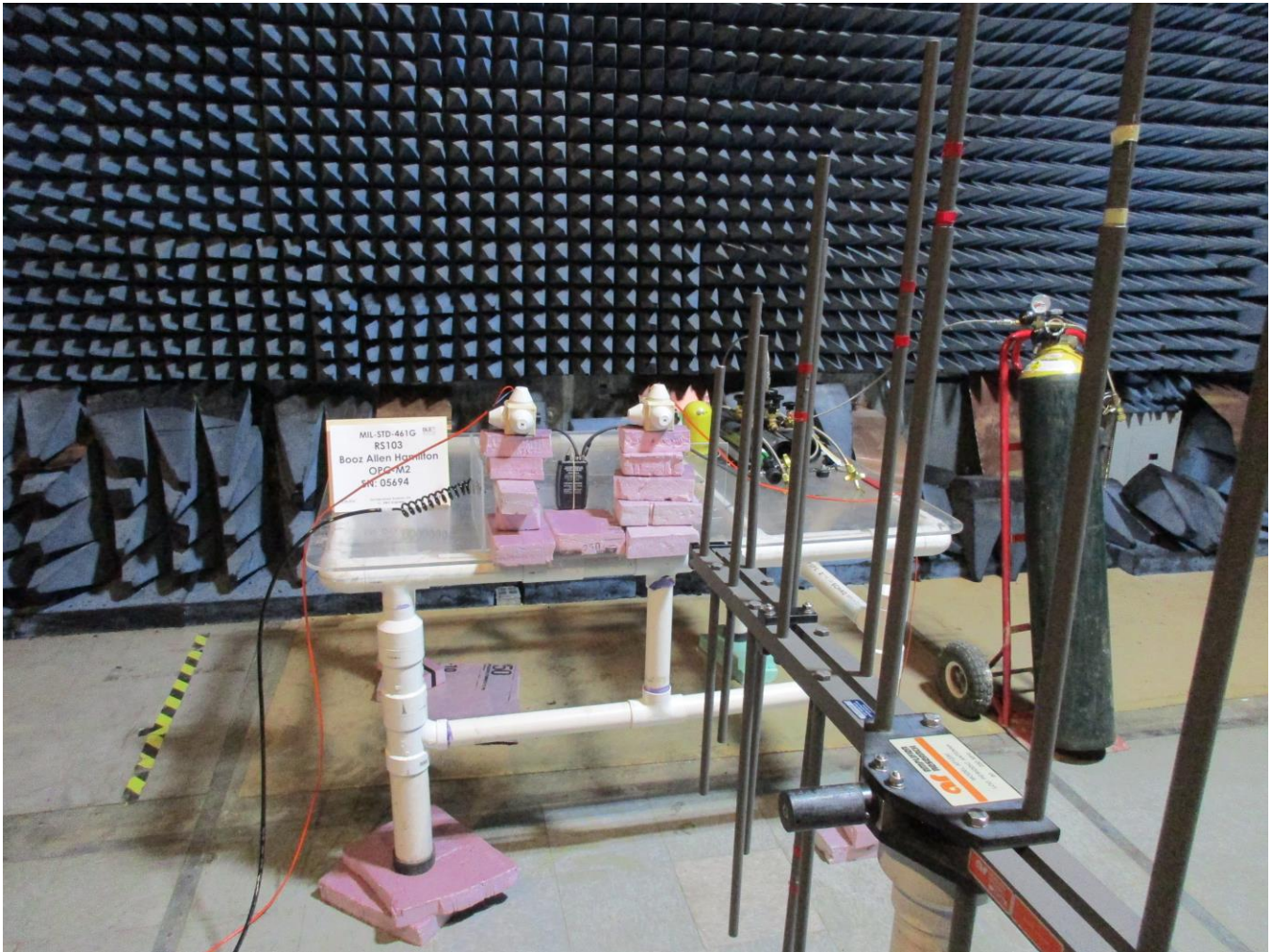

RS103 80-200MHz Vertical Test



Company: Product Management Office, Air Warrior
Model Tested: OPC-M2
Report Number: 28380
Project Number: 13049
Test: RS103, Electric Field Susceptibility



RS103 200-1000MHz Horizontal Test



Company: Product Management Office, Air Warrior
Model Tested: OPC-M2
Report Number: 28380
Project Number: 13049
Test: RS103, Electric Field Susceptibility



RS103 200-1000MHz Vertical Test



Company: Product Management Office, Air Warrior
Model Tested: OPC-M2
Report Number: 28380
Project Number: 13049
Test: RS103, Electric Field Susceptibility



RS103 1-5GHz Horizontal Test



Company: Product Management Office, Air Warrior
Model Tested: OPC-M2
Report Number: 28380
Project Number: 13049
Test: RS103, Electric Field Susceptibility

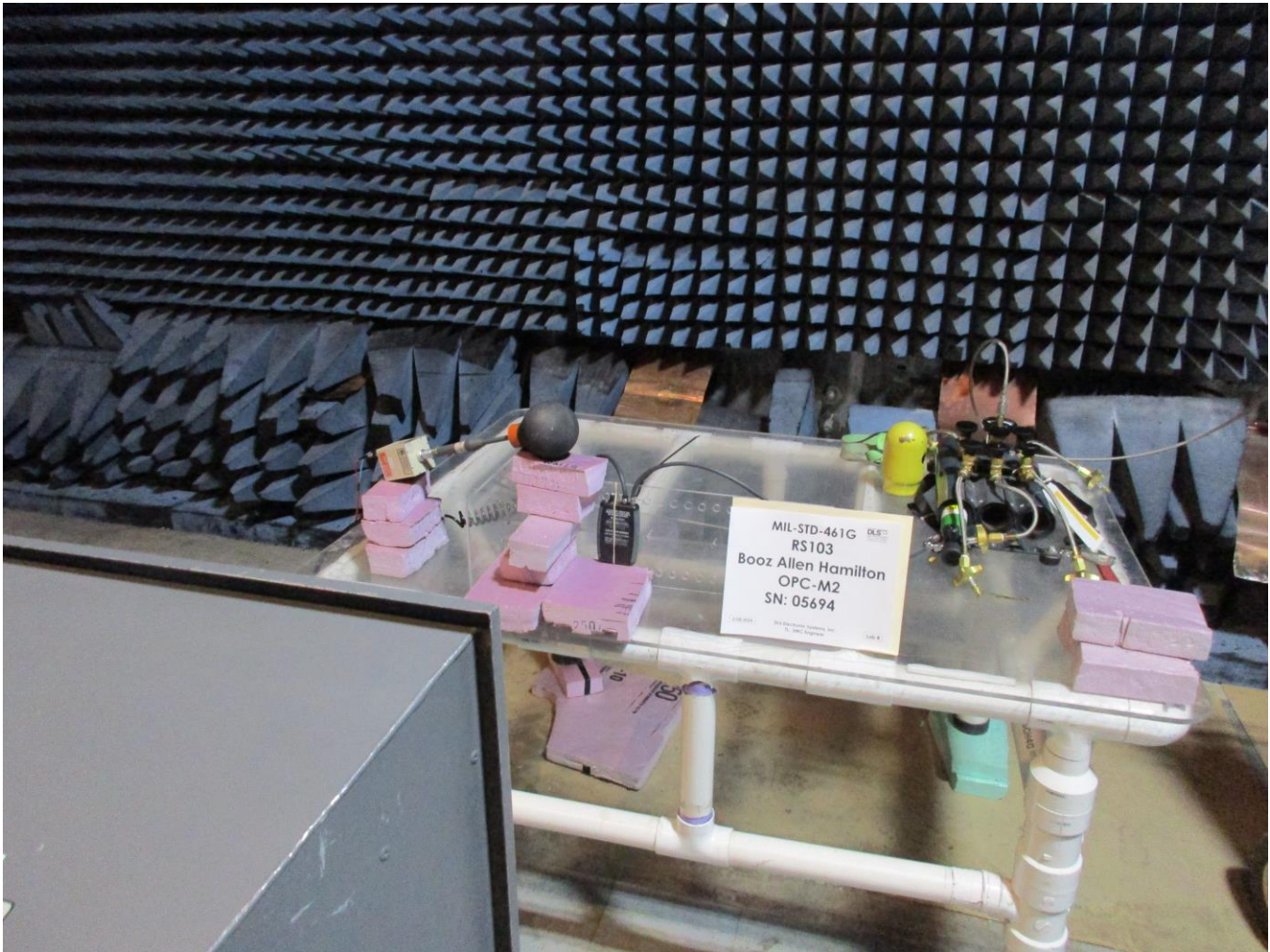

RS103 1-5GHz Vertical Test



Company: Product Management Office, Air Warrior
Model Tested: OPC-M2
Report Number: 28380
Project Number: 13049
Test: RS103, Electric Field Susceptibility



RS103 5-8GHz Horizontal Test



Company: Product Management Office, Air Warrior
Model Tested: OPC-M2
Report Number: 28380
Project Number: 13049
Test: RS103, Electric Field Susceptibility



RS103 5-8GHz Vertical Test



Company: Product Management Office, Air Warrior
Model Tested: OPC-M2
Report Number: 28380
Project Number: 13049
Test: RS103, Electric Field Susceptibility

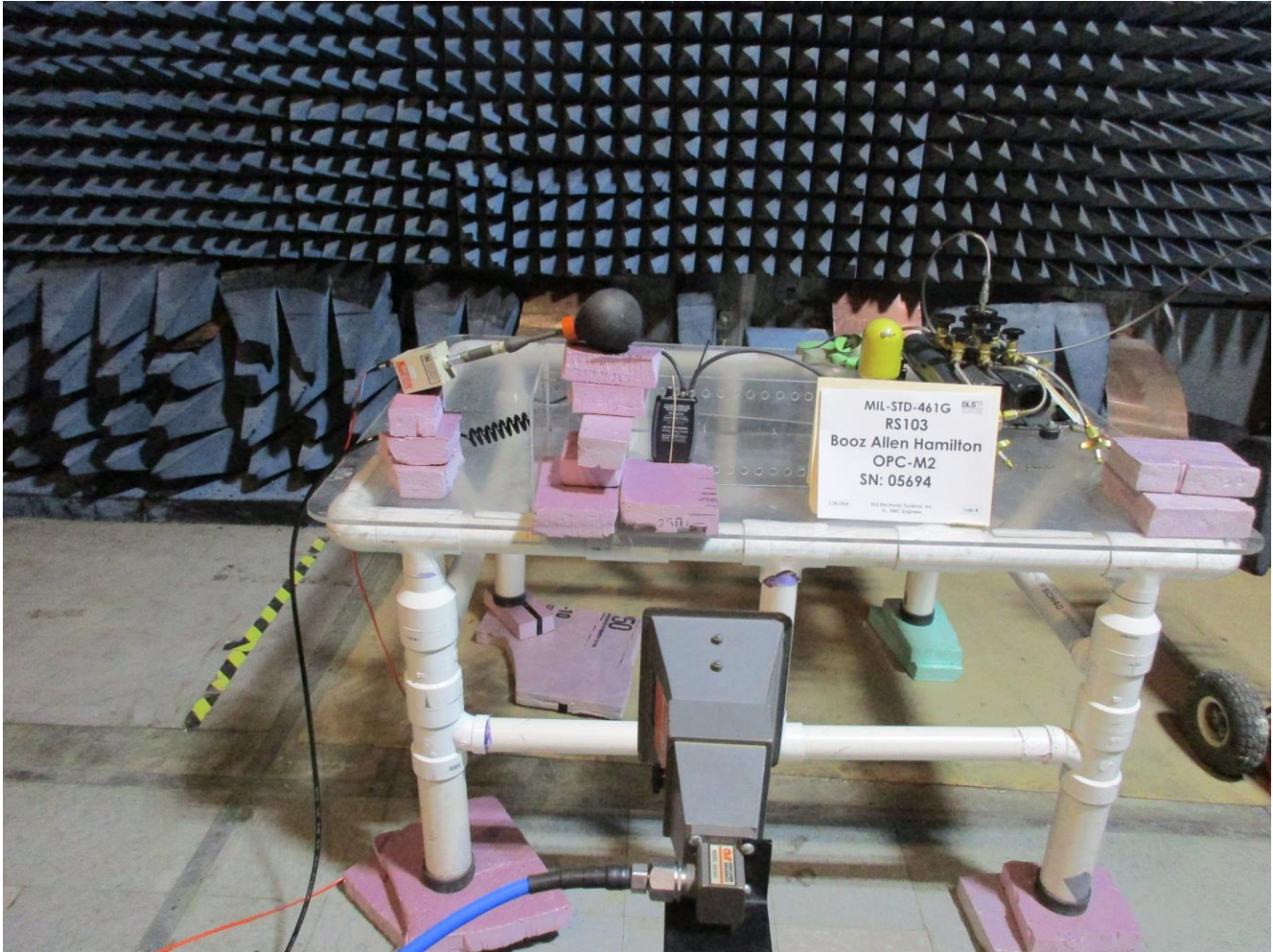

RS103 8-18GHz Horizontal Test



Company: Product Management Office, Air Warrior
Model Tested: OPC-M2
Report Number: 28380
Project Number: 13049
Test: RS103, Electric Field Susceptibility



RS103 8-18GHz Vertical Test



Company: Product Management Office, Air Warrior
Model Tested: OPC-M2
Report Number: 28380
Project Number: 13049
Test: RS103, Electric Field Susceptibility

MIL-STD-461G

RS103

RADIATED SUSCEPTIBILITY

ELECTRIC FIELD

USING

OPC-M2 EMI SOF TEST PLAN REV B 1.19.24 WITH REDLINES

TEST DATA



Company: Product Management Office, Air Warrior
 Model Tested: OPC-M2
 Report Number: 28380
 Project Number: 13049
 Test: RS103, Electric Field Susceptibility

MIL-STD-461G RS103

D.L.S. Electronic Systems, Inc

Field Probe Graph

Client - Booz Allen Hamilton
 EUT - OPC-M2 Oxygen Monitor SN:05694
 Frequency Range - EUT
 Antenna Location - Aircraft External - 200V/M
 Mode - Battery - Test Mode
 Engineer - TL

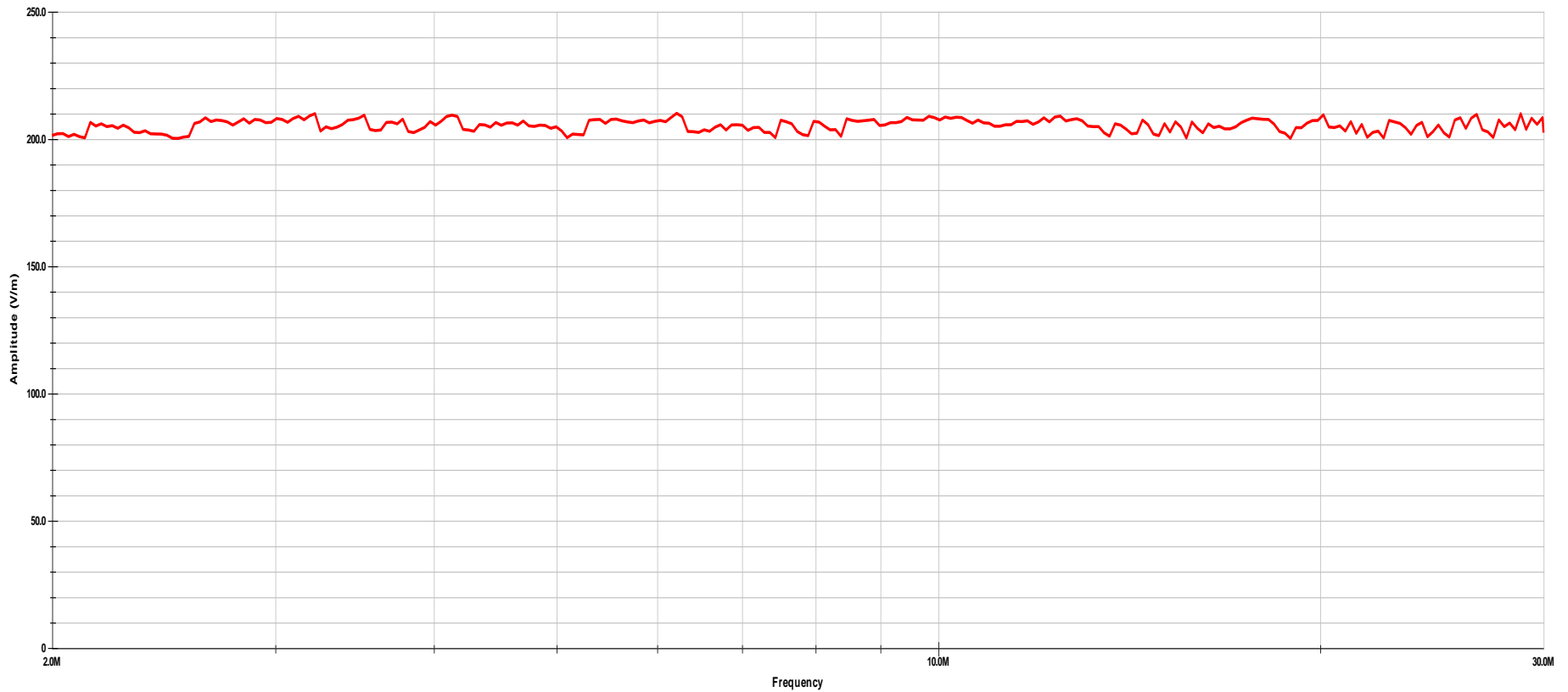

Last Data Update 03:42:58 PM, Wednesday, February 28, 2024

RS103 2-30MHz Field



Company: Product Management Office, Air Warrior
Model Tested: OPC-M2
Report Number: 28380
Project Number: 13049
Test: RS103, Electric Field Susceptibility

MIL-STD-461G RS103

D.L.S. Electronic Systems, Inc

Field Probe Graph

Client - Booz Allen Hamilton
EUT - OPC-M2 Oxygen Monitor SN:05694
Antenna Location - EUT
Level - Aircraft External - 200V/M - Horizontal
Mode - Battery - Test Mode
Engineer - TL

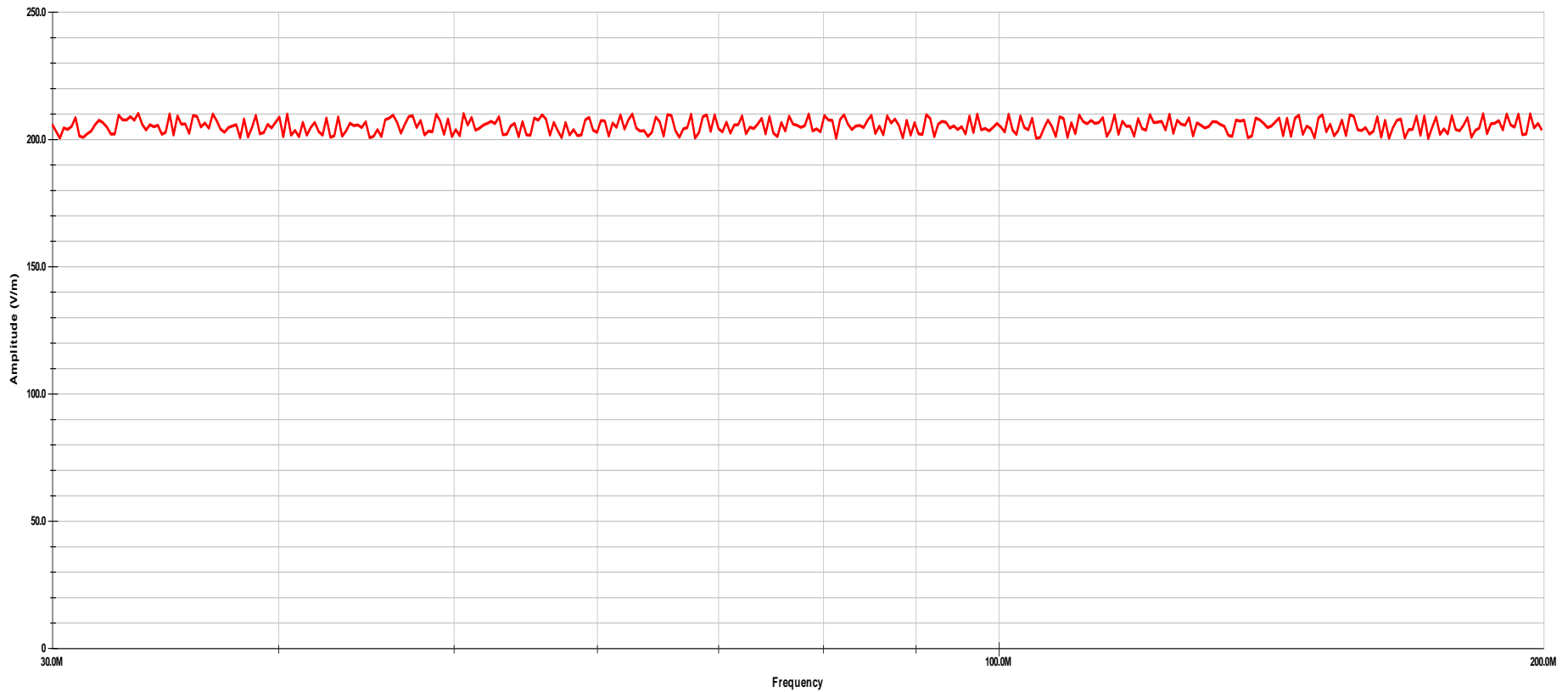

Last Data Update 02:57:38 PM, Thursday, February 29, 2024

RS103 30-200MHz Horizontal Field



Company: Product Management Office, Air Warrior
 Model Tested: OPC-M2
 Report Number: 28380
 Project Number: 13049
 Test: RS103, Electric Field Susceptibility

MIL-STD-461G RS103

D.L.S. Electronic Systems, Inc

Field Probe Graph

Client - Booz Allen Hamilton
 EUT - OPC-M2 Oxygen Monitor SN:05694
 Antenna Location - EUT
 Level - Aircraft External - 200V/M - Vertical
 Mode - Battery - Test Mode
 Engineer - TL

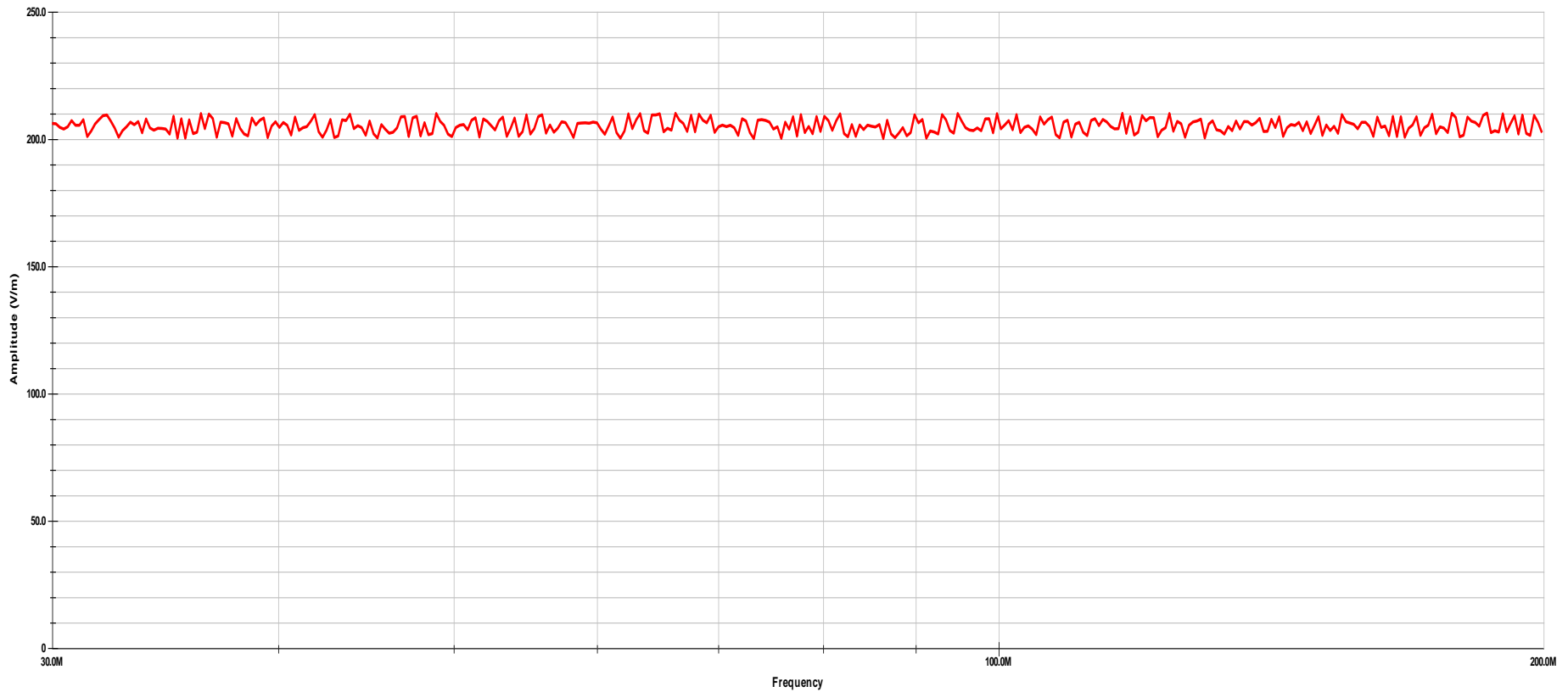

Last Data Update 11:56:44 AM, Thursday, February 29, 2024

RS103 30-200MHz Vertical Field



Company: Product Management Office, Air Warrior
 Model Tested: OPC-M2
 Report Number: 28380
 Project Number: 13049
 Test: RS103, Electric Field Susceptibility

MIL-STD-461G RS103

D.L.S. Electronic Systems, Inc

Field Probe Graph

Client - Booz Allen Hamilton
 EUT - OPC-M2 Oxygen Monitor SN:05694
 Antenna Location - EUT
 Level - Aircraft External - 200V/M - Horizontal
 Mode - Battery - Test Mode
 Engineer - TL

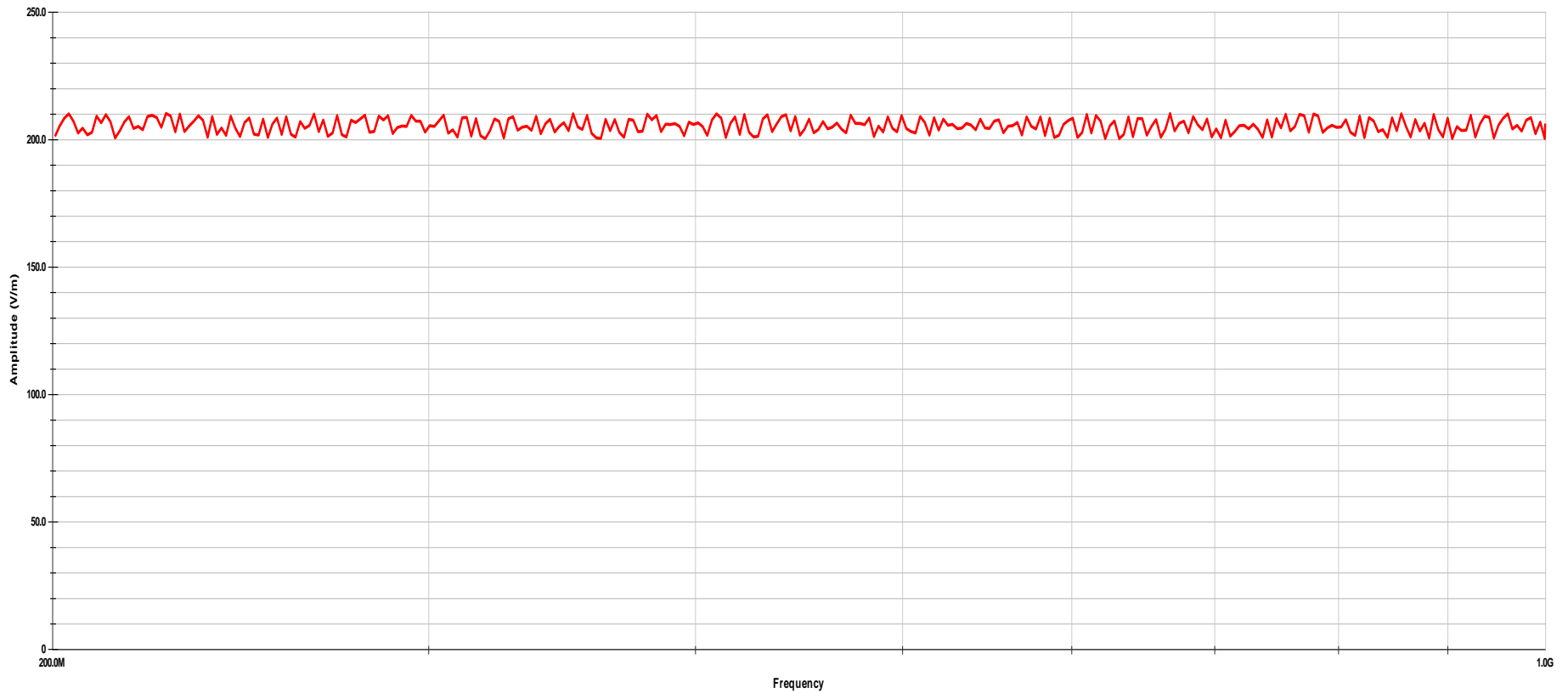

Last Data Update 04:02:59 PM, Thursday, February 29, 2024

RS103 200-1000MHz Horizontal Field



Company: Product Management Office, Air Warrior
 Model Tested: OPC-M2
 Report Number: 28380
 Project Number: 13049
 Test: RS103, Electric Field Susceptibility

MIL-STD-461G RS103

D.L.S. Electronic Systems, Inc

Field Probe Graph

Client - Booz Allen Hamilton
 EUT - OPC-M2 Oxygen Monitor SN:05694
 Antenna Location - EUT
 Level - Aircraft External - 200V/M - Vertical
 Mode - Battery - Test Mode
 Engineer - TL

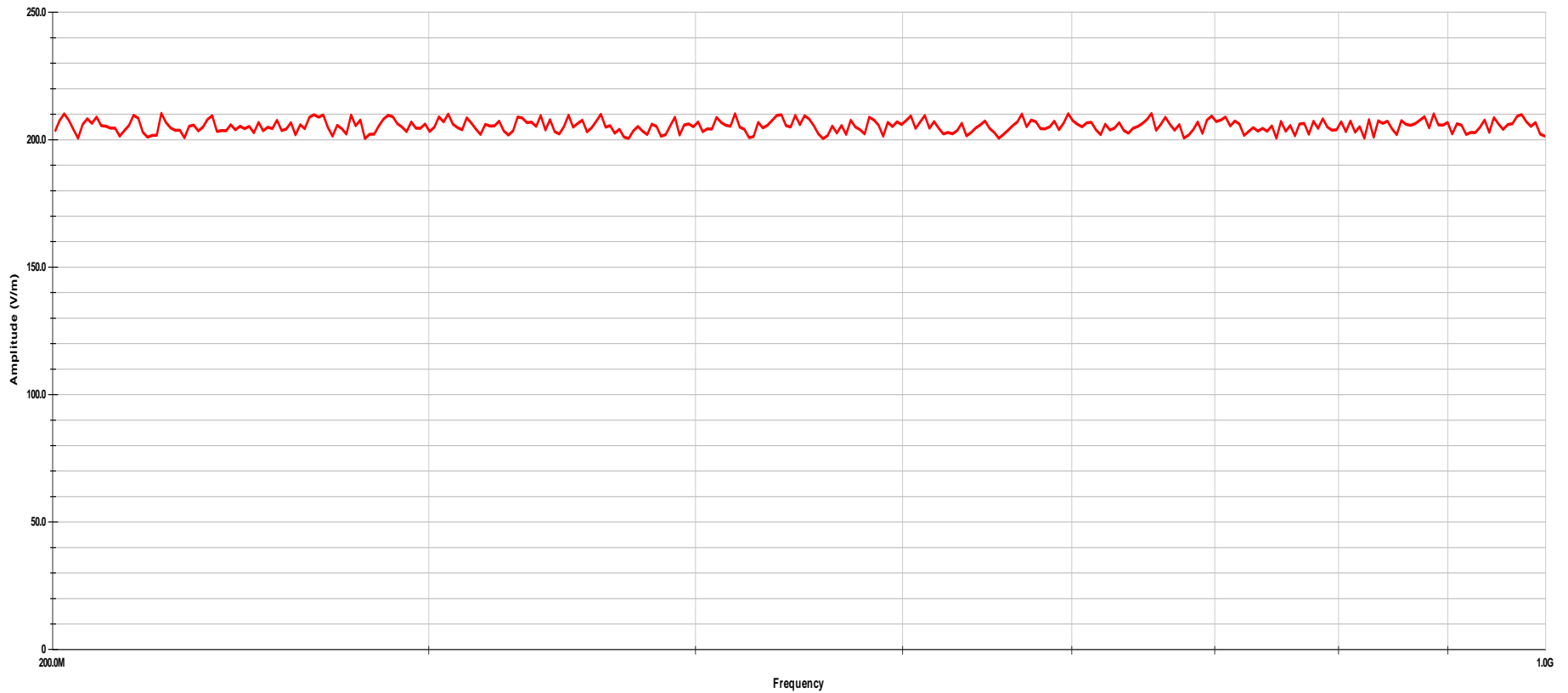

Last Data Update 09:03:04 AM, Friday, March 01, 2024

RS103 200-1000MHz Vertical Field



Company: Product Management Office, Air Warrior
 Model Tested: OPC-M2
 Report Number: 28380
 Project Number: 13049
 Test: RS103, Electric Field Susceptibility

MIL-STD-461G RS103

D.L.S. Electronic Systems, Inc

Field Probe Graph

Client - Booz Allen Hamilton
 EUT - OPC-M2 Oxygen Monitor SN:05694
 Antenna Location - EUT
 Level - Aircraft External - 200V/M - Vertical
 Mode - Battery - Test Mode
 Engineer - TL

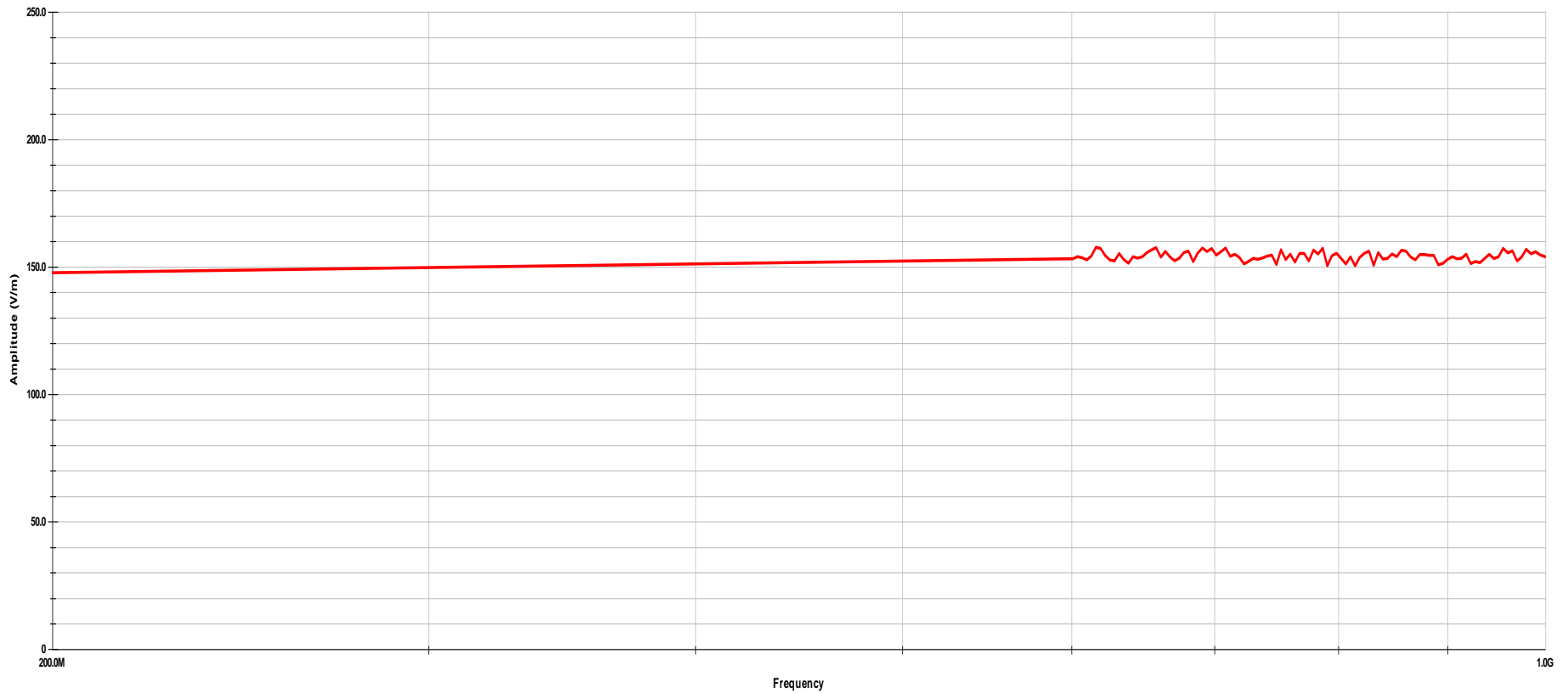

Last Data Update 10:11:57 AM, Friday, March 01, 2024

RS103 600-1000MHz Vertical Field 150V THold



Company: Product Management Office, Air Warrior
Model Tested: OPC-M2
Report Number: 28380
Project Number: 13049
Test: RS103, Electric Field Susceptibility

MIL-STD-461G RS103

D.L.S. Electronic Systems, Inc

Field Probe Graph

Client - Booz Allen Hamilton
EUT - OPC-M2 Oxygen Monitor SN:05694
Antenna Location - EUT
Level - Aircraft External - 200V/M - Vertical
Mode - Battery - Test Mode
Engineer - TL

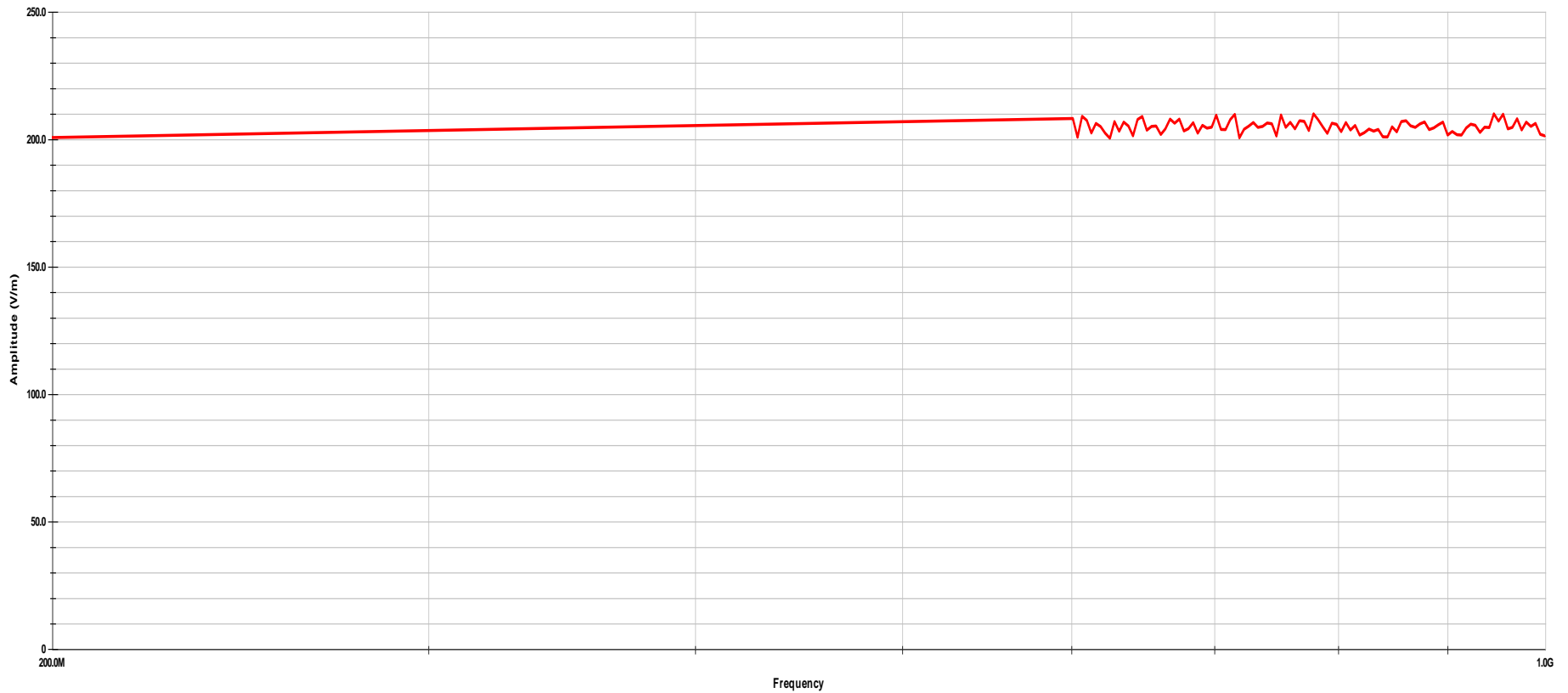

Last Data Update 09:38:49 AM, Friday, March 01, 2024

RS103 600-1000MHz Vertical Field 200V



Company: Product Management Office, Air Warrior
 Model Tested: OPC-M2
 Report Number: 28380
 Project Number: 13049
 Test: RS103, Electric Field Susceptibility

MIL-STD-461G RS103

D.L.S. Electronic Systems, Inc

Field Probe Graph

Client - Booz Allen Hamilton
 EUT - OPC-M2 Oxygen Monitor SN:05694
 Antenna Location - EUT
 Level - Aircraft External - 200V/M - Horizontal
 Mode - Battery - Test Mode
 Engineer - TL

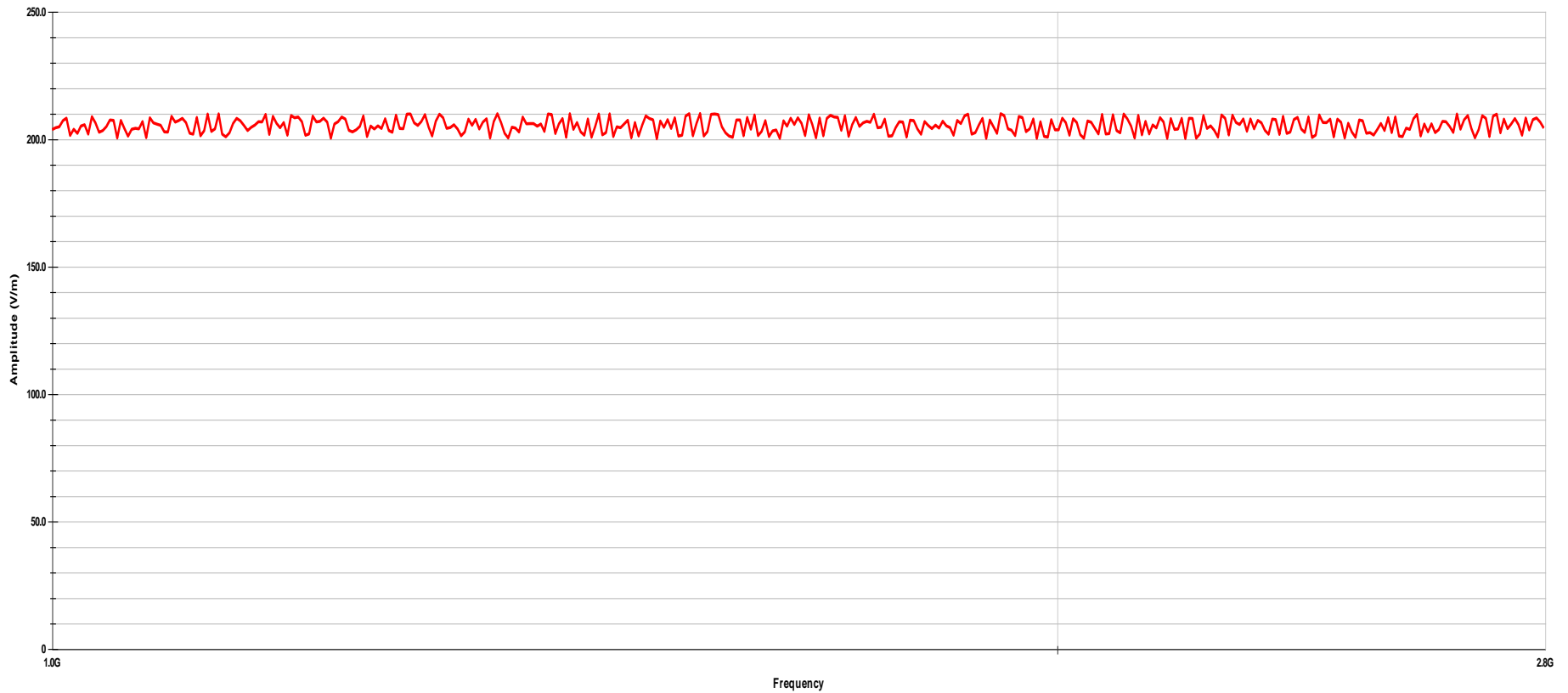

Last Data Update 02:24:14 PM, Friday, March 01, 2024

RS103 1-2.8GHz Horizontal Field



Company: Product Management Office, Air Warrior
 Model Tested: OPC-M2
 Report Number: 28380
 Project Number: 13049
 Test: RS103, Electric Field Susceptibility

MIL-STD-461G RS103

D.L.S. Electronic Systems, Inc

Field Probe Graph

Client - Booz Allen Hamilton
 EUT - OPC-M2 Oxygen Monitor SN:05694
 Antenna Location - EUT
 Level - Aircraft External - 200V/M - Vertical
 Mode - Battery - Test Mode
 Engineer - TL

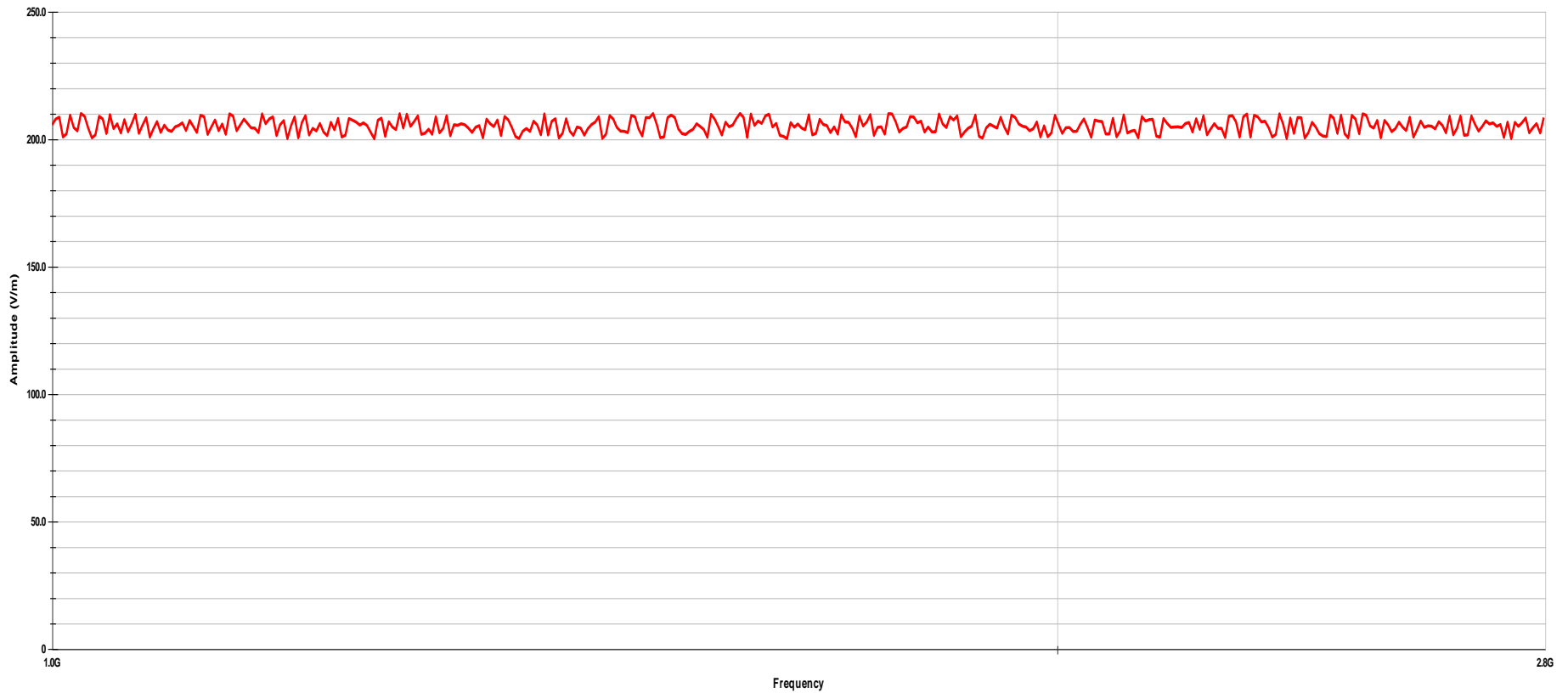

Last Data Update 03:32:18 PM, Friday, March 01, 2024

RS103 1-2.8GHz Vertical Field



Company: Product Management Office, Air Warrior
Model Tested: OPC-M2
Report Number: 28380
Project Number: 13049
Test: RS103, Electric Field Susceptibility

MIL-STD-461G RS103

D.L.S. Electronic Systems, Inc

Field Probe Graph

Client - Booz Allen Hamilton
EUT - OPC-M2 Oxygen Monitor SN:05694
Antenna Location - EUT
Level - Aircraft External - 200V/M - Horizontal
Mode - Battery - Test Mode
Engineer - TL

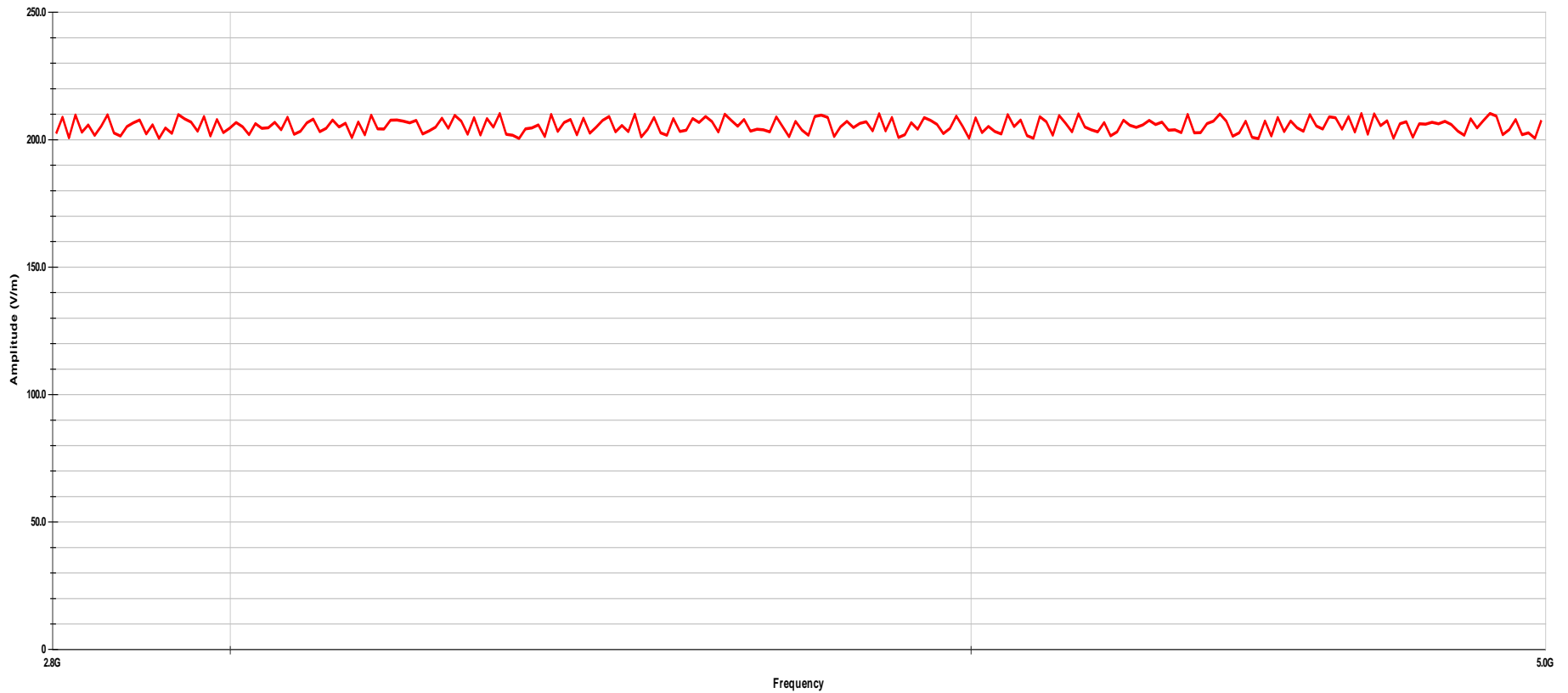

Last Data Update 10:10:16 AM, Monday, March 04, 2024

RS103 2.8-5GHz Horizontal Field



Company: Product Management Office, Air Warrior
 Model Tested: OPC-M2
 Report Number: 28380
 Project Number: 13049
 Test: RS103, Electric Field Susceptibility

MIL-STD-461G RS103

D.L.S. Electronic Systems, Inc

Field Probe Graph

Client - Booz Allen Hamilton
 EUT - OPC-M2 Oxygen Monitor SN:05694
 Antenna Location - EUT
 Level - Aircraft External - 200V/M - Vertical
 Mode - Battery - Test Mode
 Engineer - TL

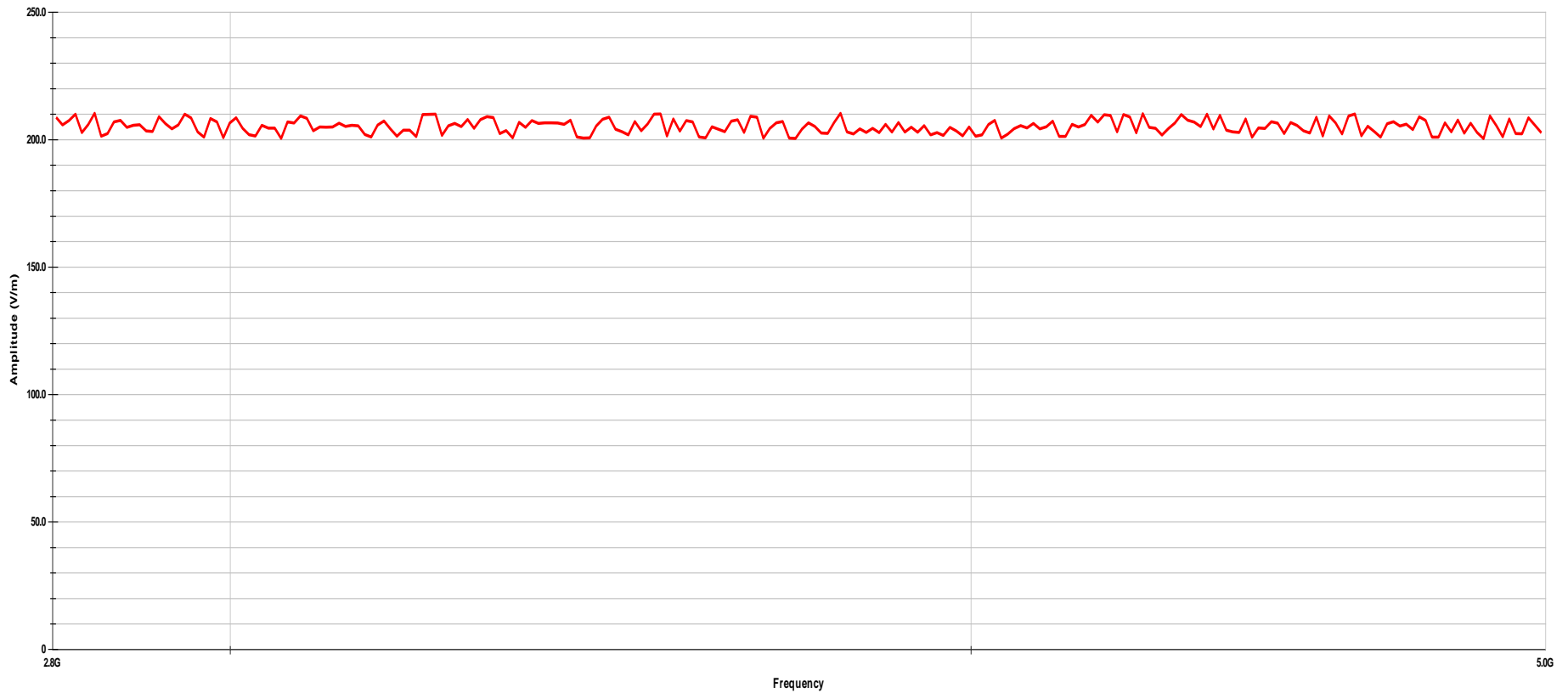

Last Data Update 09:03:18 AM, Monday, March 04, 2024

RS103 2.8-5GHz Vertical Field



Company: Product Management Office, Air Warrior
 Model Tested: OPC-M2
 Report Number: 28380
 Project Number: 13049
 Test: RS103, Electric Field Susceptibility

MIL-STD-461G RS103

D.L.S. Electronic Systems, Inc

Field Probe Graph

Client - Booz Allen Hamilton
 EUT - OPC-M2 Oxygen Monitor SN:05694
 Antenna Location - EUT
 Level - Aircraft External - 200V/M - Horizontal
 Mode - Battery - Test Mode
 Engineer - TL

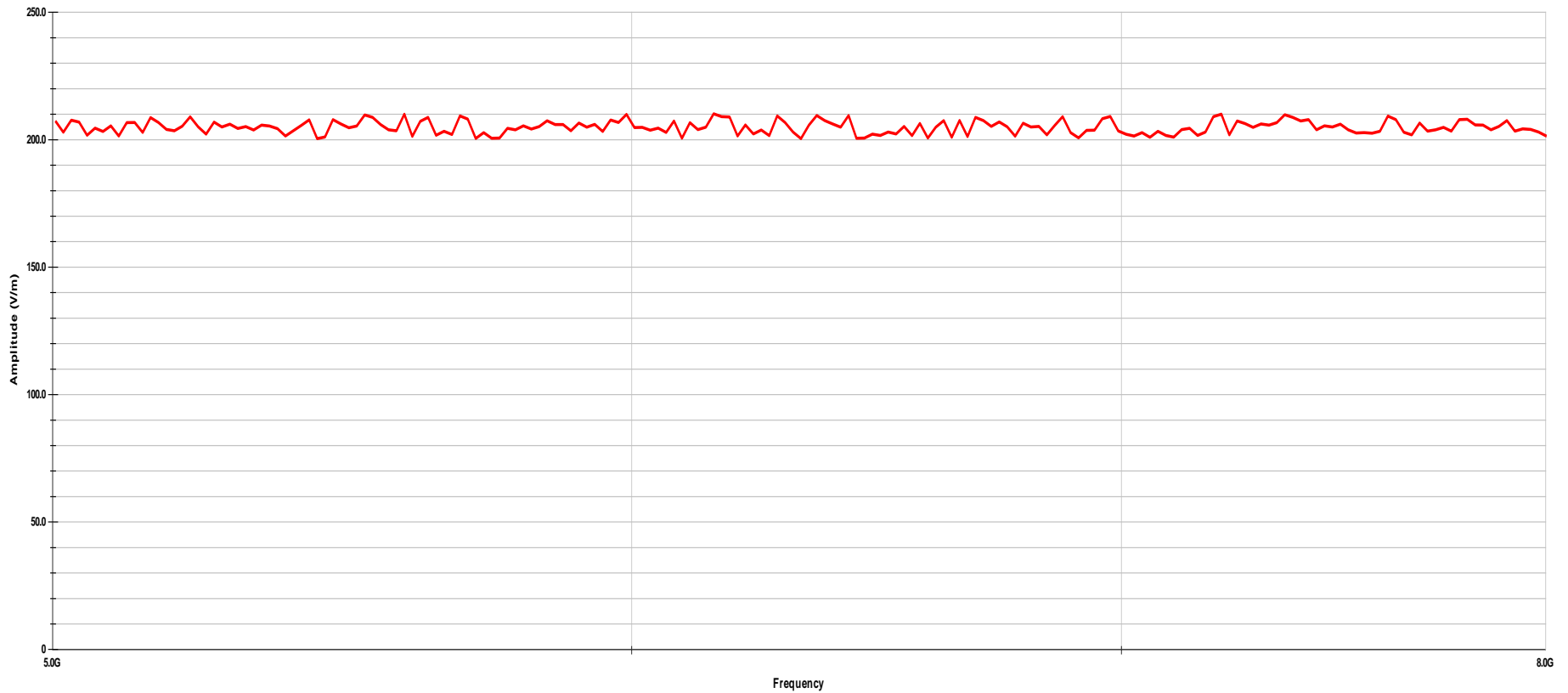

Last Data Update 12:12:49 PM, Monday, March 04, 2024

RS103 5-8GHz Horizontal Field



Company: Product Management Office, Air Warrior
 Model Tested: OPC-M2
 Report Number: 28380
 Project Number: 13049
 Test: RS103, Electric Field Susceptibility

MIL-STD-461G RS103

D.L.S. Electronic Systems, Inc

Field Probe Graph

Client - Booz Allen Hamilton
 EUT - OPC-M2 Oxygen Monitor SN:05694
 Antenna Location - EUT
 Level - Aircraft External - 200V/M - Vertical
 Mode - Battery - Test Mode
 Engineer - TL

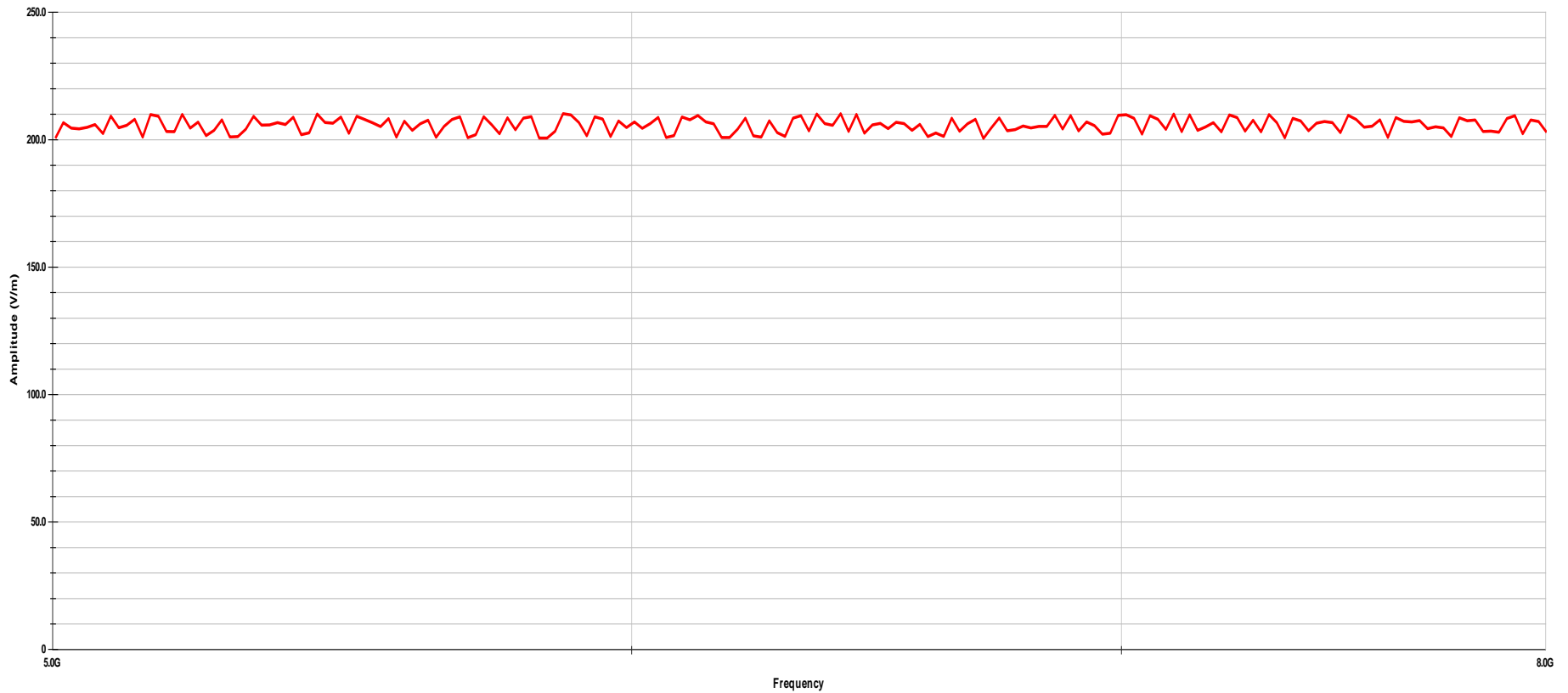

Last Data Update 10:59:41 AM, Monday, March 04, 2024

RS103 5-8GHz Vertical Field



Company: Product Management Office, Air Warrior
Model Tested: OPC-M2
Report Number: 28380
Project Number: 13049
Test: RS103, Electric Field Susceptibility

MIL-STD-461G RS103

D.L.S. Electronic Systems, Inc

Field Probe Graph

Client - Booz Allen Hamilton
EUT - OPC-M2 Oxygen Monitor SN:05694
Antenna Location - EUT
Level - Aircraft External - 200V/M - Horizontal
Mode - Battery - Test Mode
Engineer - TL

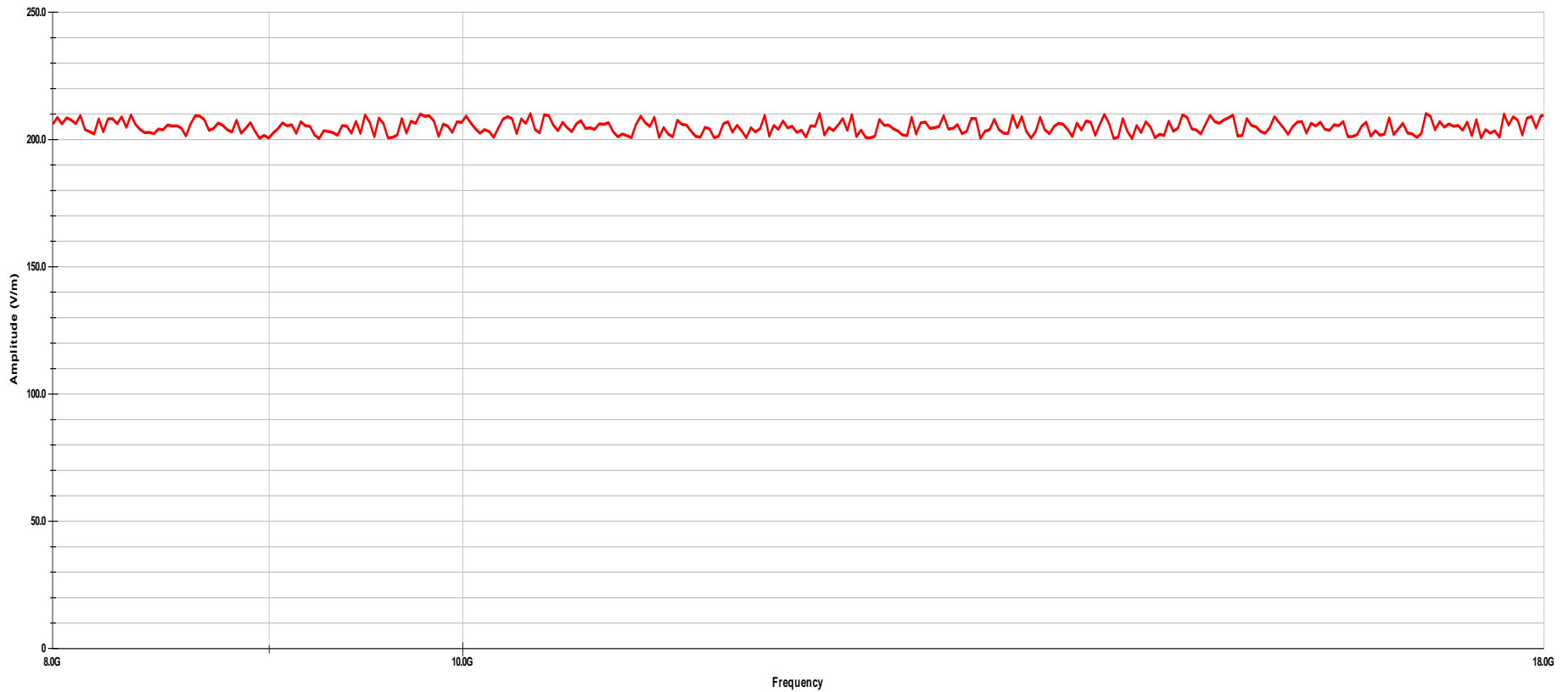

Last Data Update 02:23:01 PM, Monday, March 04, 2024

RS103 8-18GHz Horizontal Field



Company: Product Management Office, Air Warrior
 Model Tested: OPC-M2
 Report Number: 28380
 Project Number: 13049
 Test: RS103, Electric Field Susceptibility

MIL-STD-461G RS103

D.L.S. Electronic Systems, Inc

Field Probe Graph

Client - Booz Allen Hamilton
 EUT - OPC-M2 Oxygen Monitor SN:05694
 Antenna Location - EUT
 Level - Aircraft External - 200V/M - Vertical
 Mode - Battery - Test Mode
 Engineer - TL

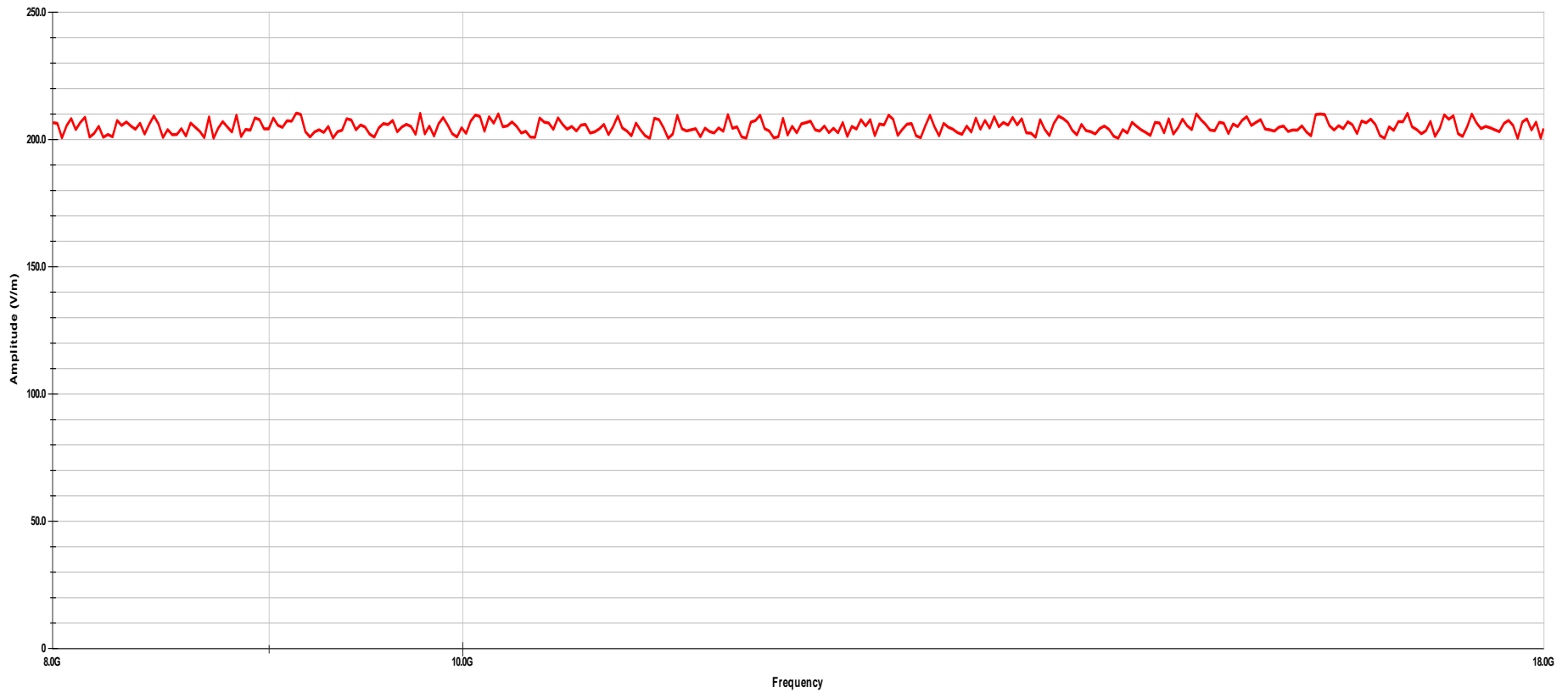

Last Data Update 01:32:01 PM, Monday, March 04, 2024

RS103 8-18GHz Vertical Field



Company: Product Management Office, Air Warrior
Model Tested: OPC-M2
Report Number: 28380
Project Number: 13049
Test: RS103, Electric Field Susceptibility

MIL-STD-461G

RS103

RADIATED SUSCEPTIBILITY

ELECTRIC FIELD

USING

OPC-M2 EMI SOF TEST PLAN REV B 1.19.24 WITH REDLINES

EUT MONITORING DATA

Note: The Y-Axis of all plots is Oxygen Flow in Liters per minute (LPM)



Company: Product Management Office, Air Warrior
Model Tested: OPC-M2
Report Number: 28380
Project Number: 13049
Test: RS103, Electric Field Susceptibility

RS103 2-30MHz 200V/M

EUT Data

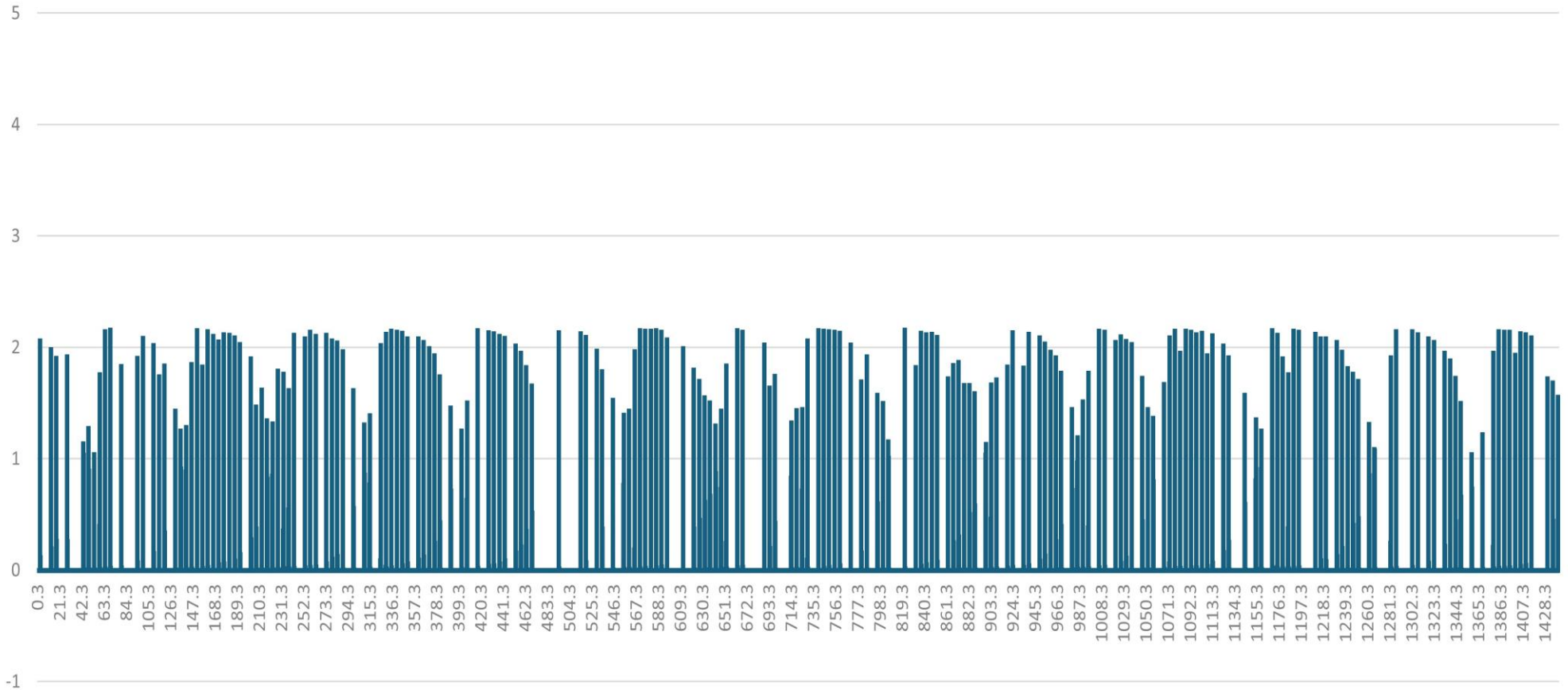

RS103 2-30MHz Vertical Excel Plot



Company: Product Management Office, Air Warrior
 Model Tested: OPC-M2
 Report Number: 28380
 Project Number: 13049
 Test: RS103, Electric Field Susceptibility

RS103 30-80MHz Horizontal Polarization 200V/M

■ EUT Data

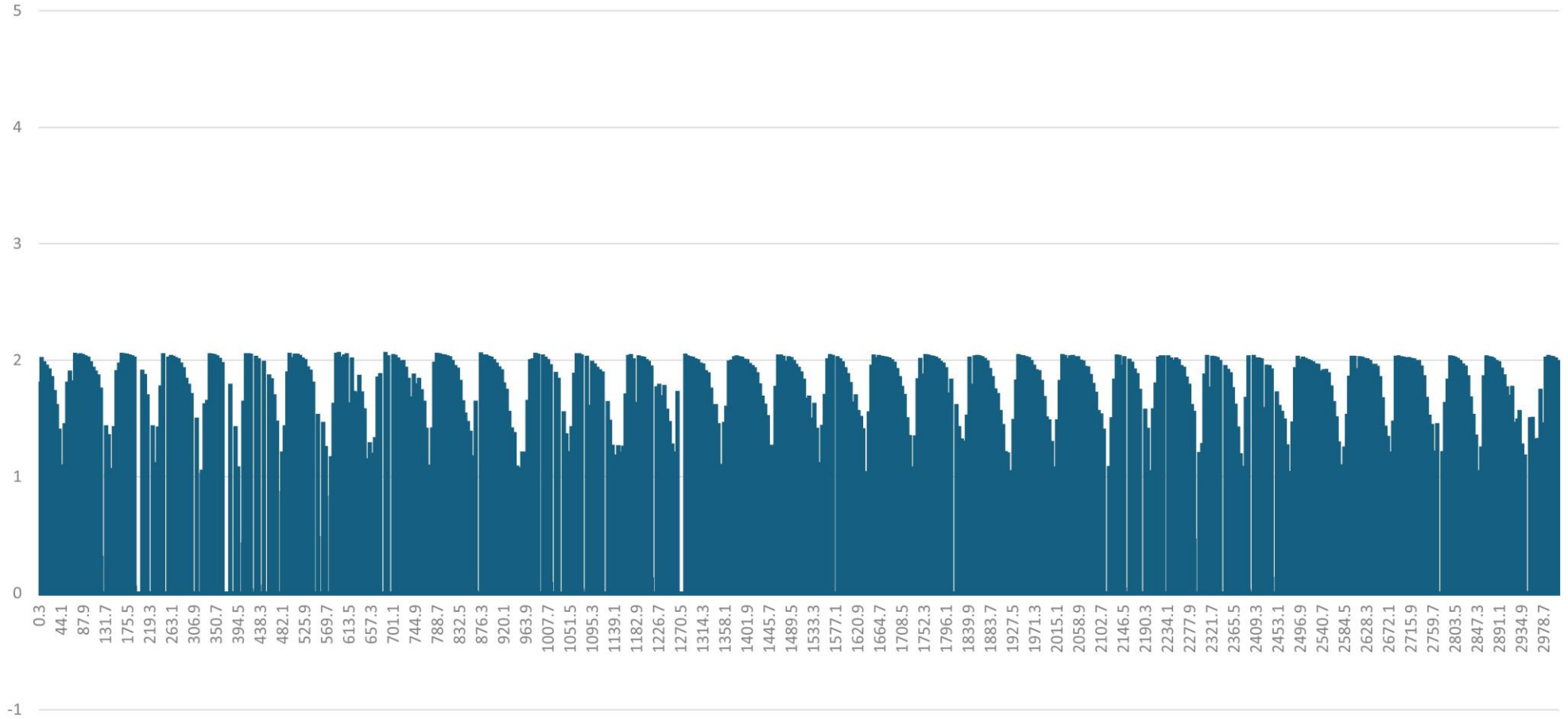

RS103 30-80MHz Horizontal Excel Plot



Company: Product Management Office, Air Warrior
Model Tested: OPC-M2
Report Number: 28380
Project Number: 13049
Test: RS103, Electric Field Susceptibility

RS103 30-80MHz Vertical Polarization 200V/M

EUT Data

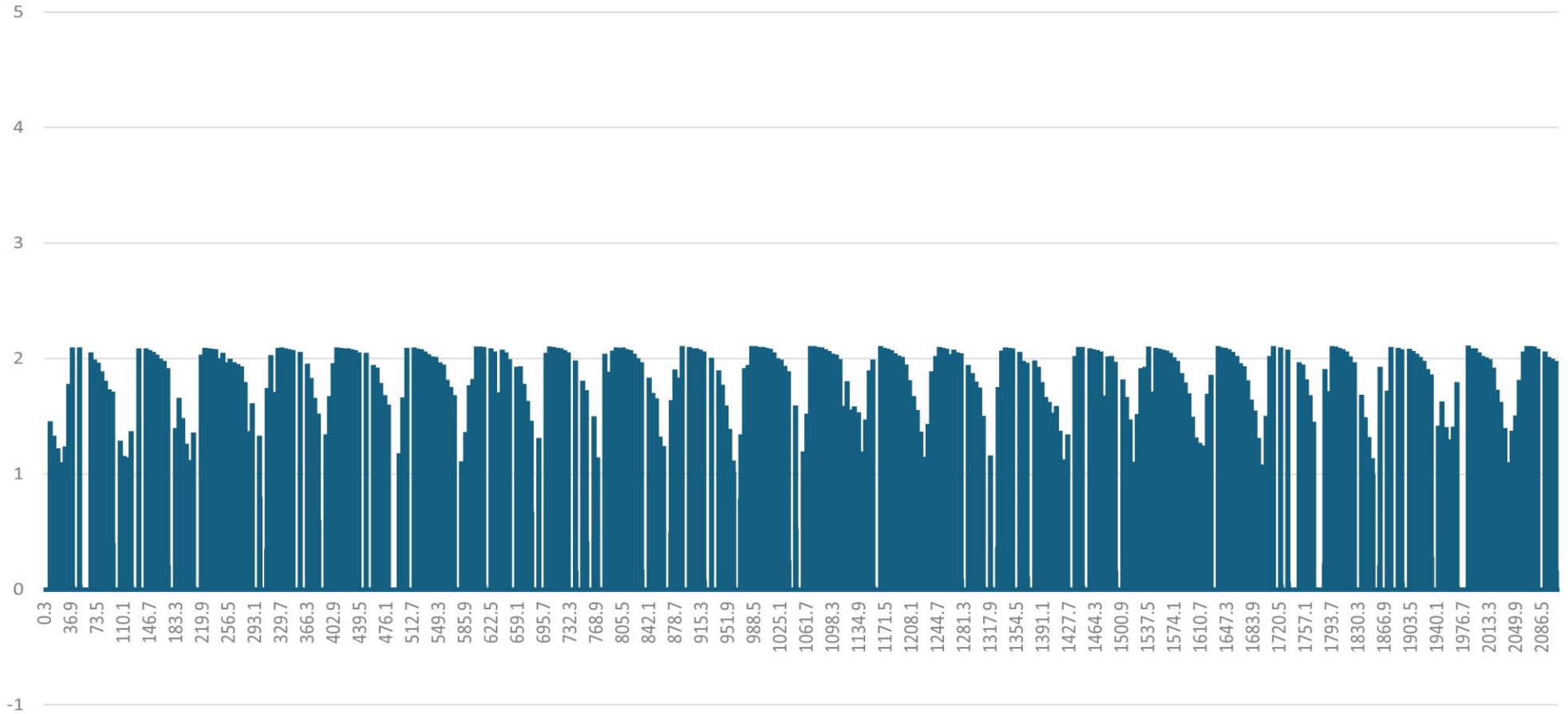

RS103 30-80MHz Vertical Excel Plot



Company: Product Management Office, Air Warrior
Model Tested: OPC-M2
Report Number: 28380
Project Number: 13049
Test: RS103, Electric Field Susceptibility

RS103 80-200MHz Horizontal Polarity 200V/M

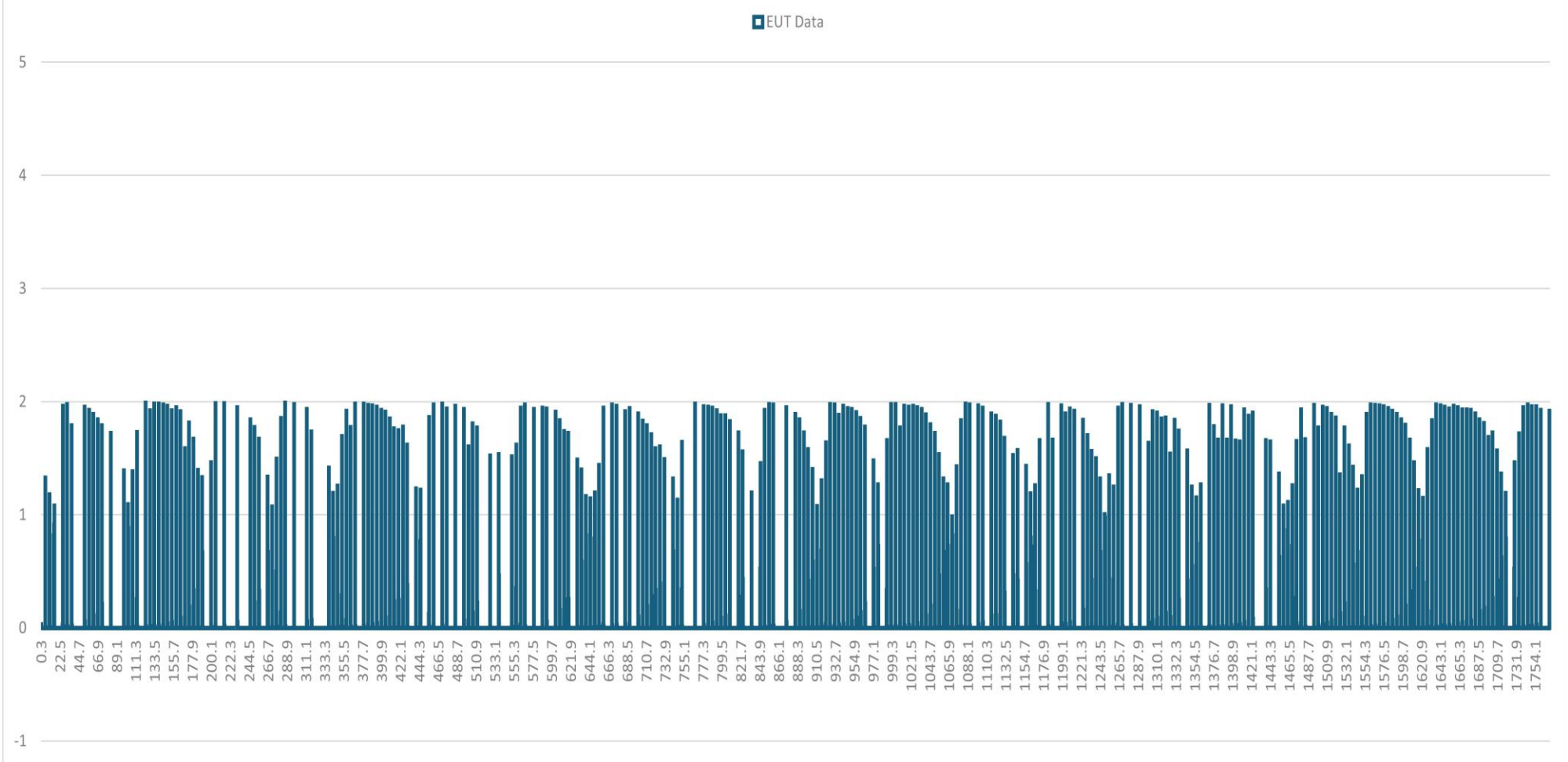

RS103 80-200MHz Horizontal Excel Plot



Company: Product Management Office, Air Warrior
 Model Tested: OPC-M2
 Report Number: 28380
 Project Number: 13049
 Test: RS103, Electric Field Susceptibility

RS103 80-200MHz Vertical Polarization 200V/M

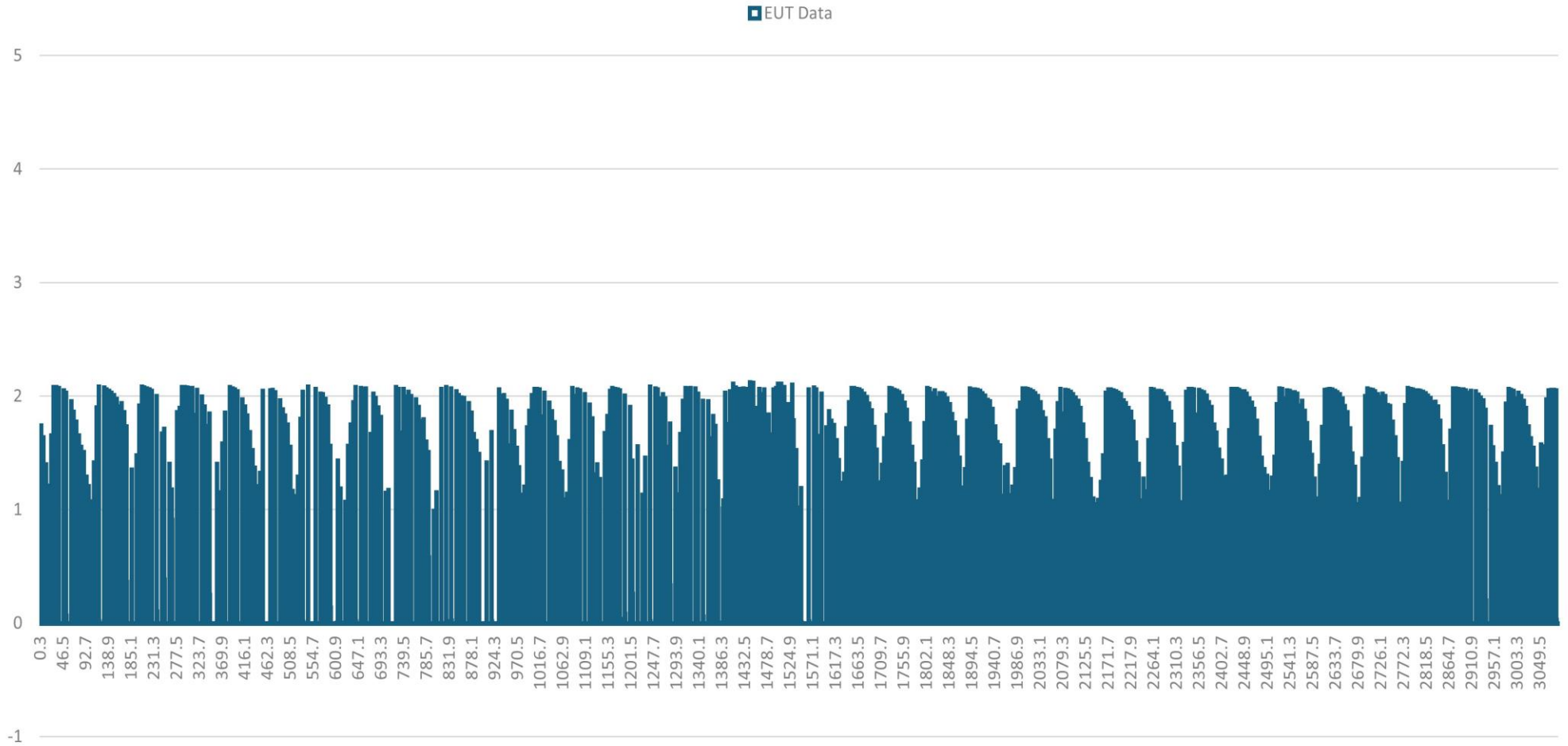

RS103 80-200MHz Vertical Excel Plot



Company: Product Management Office, Air Warrior
Model Tested: OPC-M2
Report Number: 28380
Project Number: 13049
Test: RS103, Electric Field Susceptibility

200-1000MHz Horizontal Polarization 200V/M

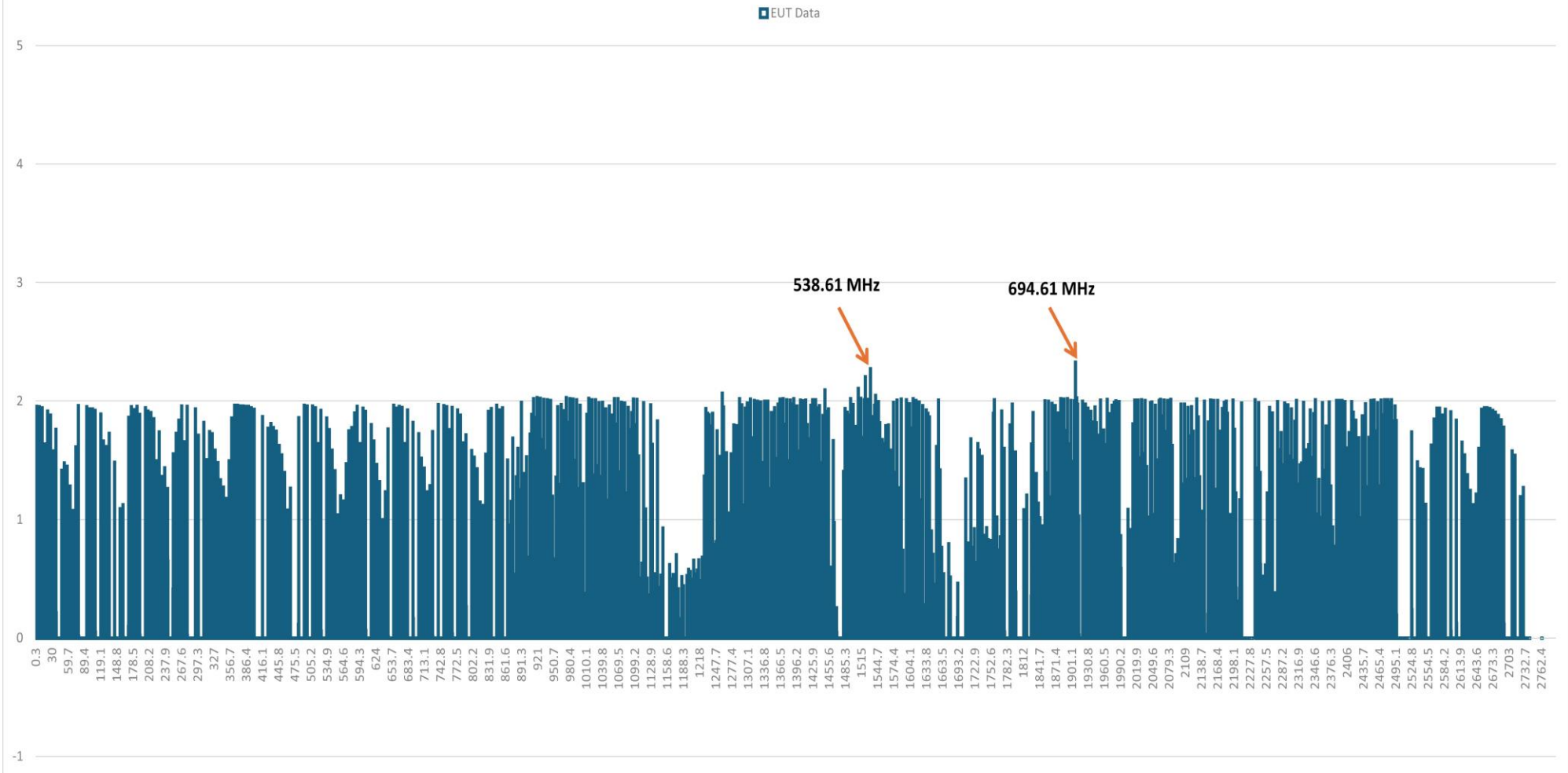

RS103 200-1000MHz Horizontal Excel Plot



Company: Product Management Office, Air Warrior
Model Tested: OPC-M2
Report Number: 28380
Project Number: 13049
Test: RS103, Electric Field Susceptibility

200-1000MHz Vertical Polarization 200V/M

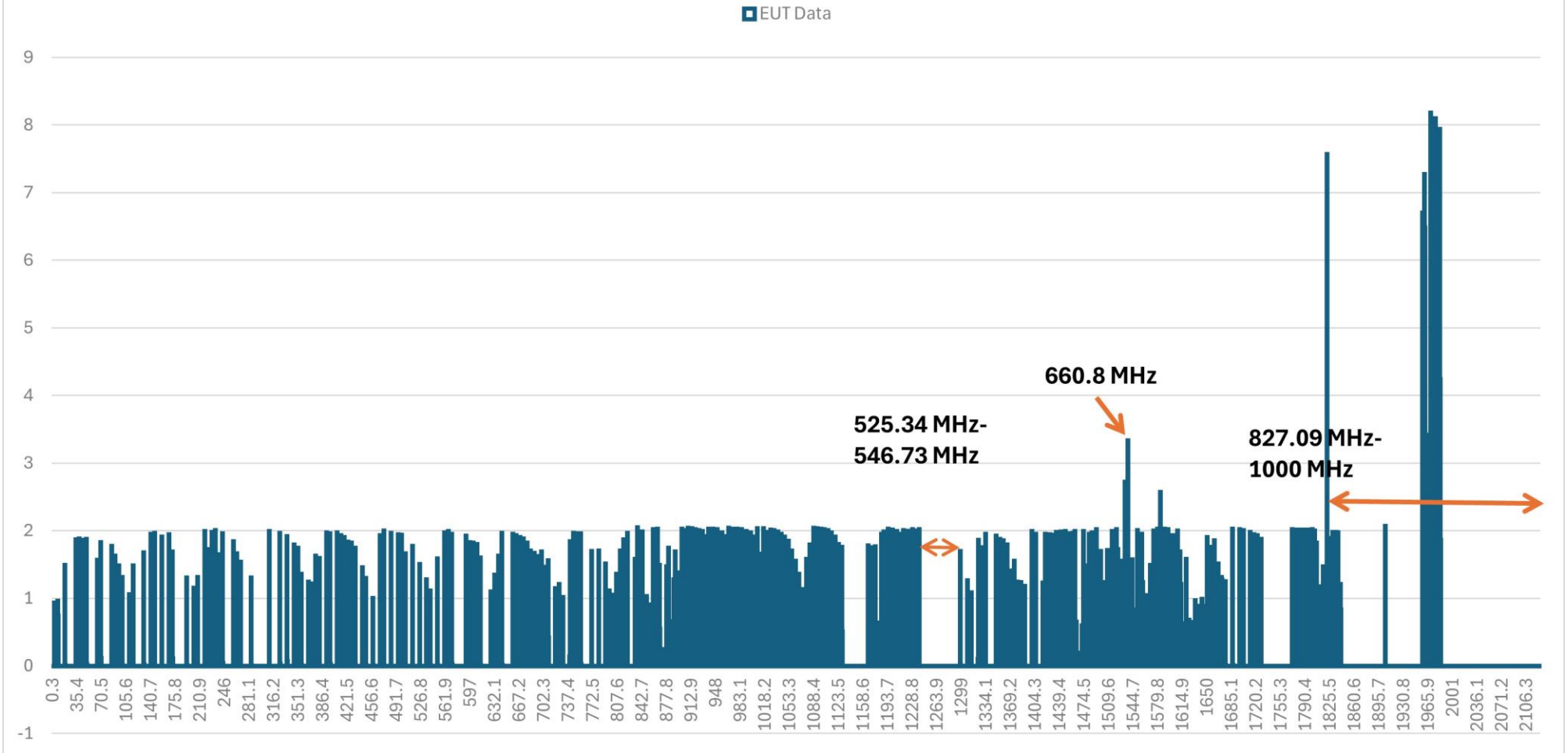

RS103 200-1000MHz Vertical Excel Plot



Company: Product Management Office, Air Warrior
Model Tested: OPC-M2
Report Number: 28380
Project Number: 13049
Test: RS103, Electric Field Susceptibility

RS103 1-2.8GHz Horizontal Polarization 200V/M

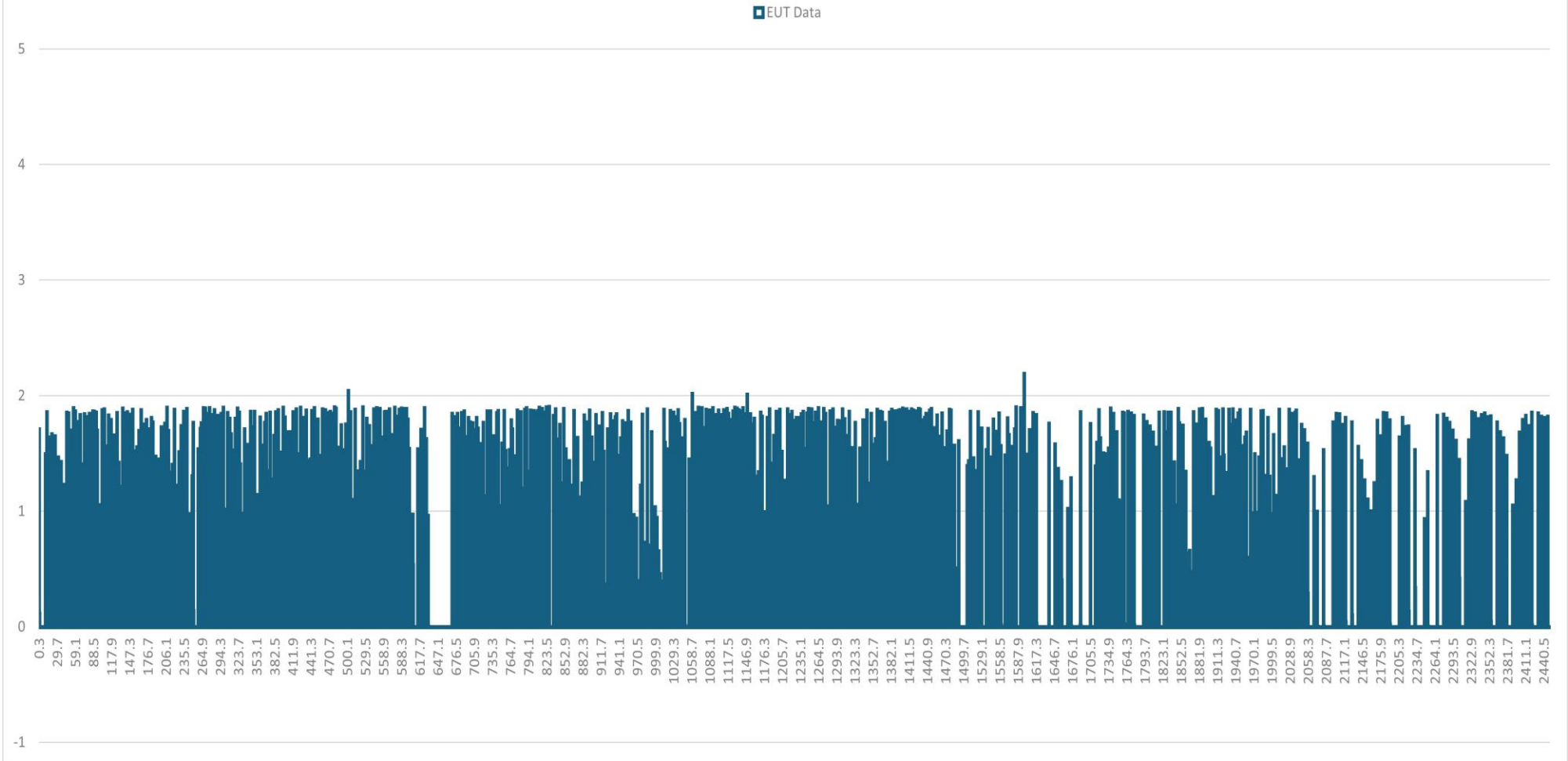

RS103 1-2.8GHz Horizontal Excel Plot



Company: Product Management Office, Air Warrior
Model Tested: OPC-M2
Report Number: 28380
Project Number: 13049
Test: RS103, Electric Field Susceptibility

1-2.8GHz Vertical Polarization 200V/M

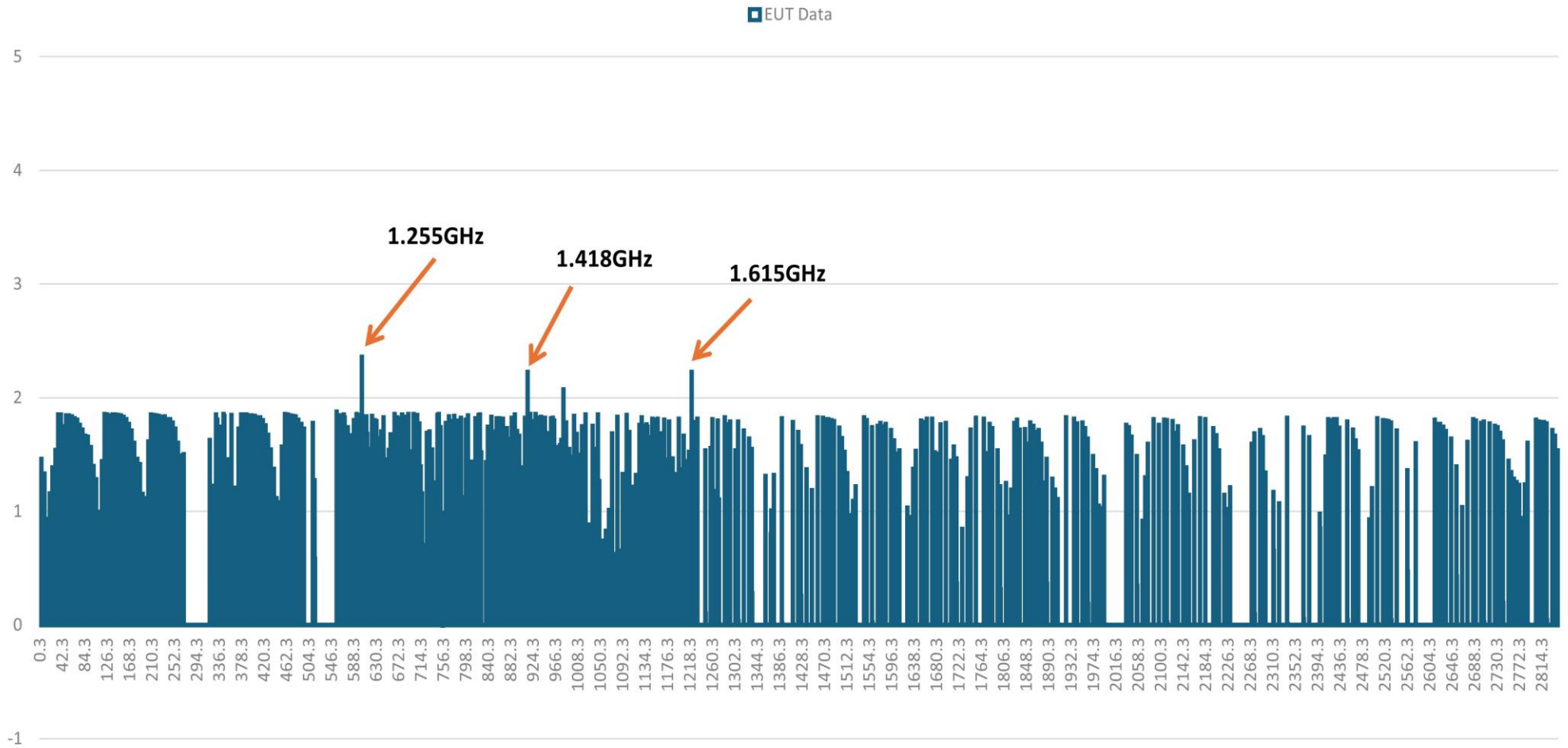

RS103 1-2.8GHz Vertical Excel Plot



Company: Product Management Office, Air Warrior
Model Tested: OPC-M2
Report Number: 28380
Project Number: 13049
Test: RS103, Electric Field Susceptibility

RS103 2.8-5GHz Horizontal Polarity 200V/M

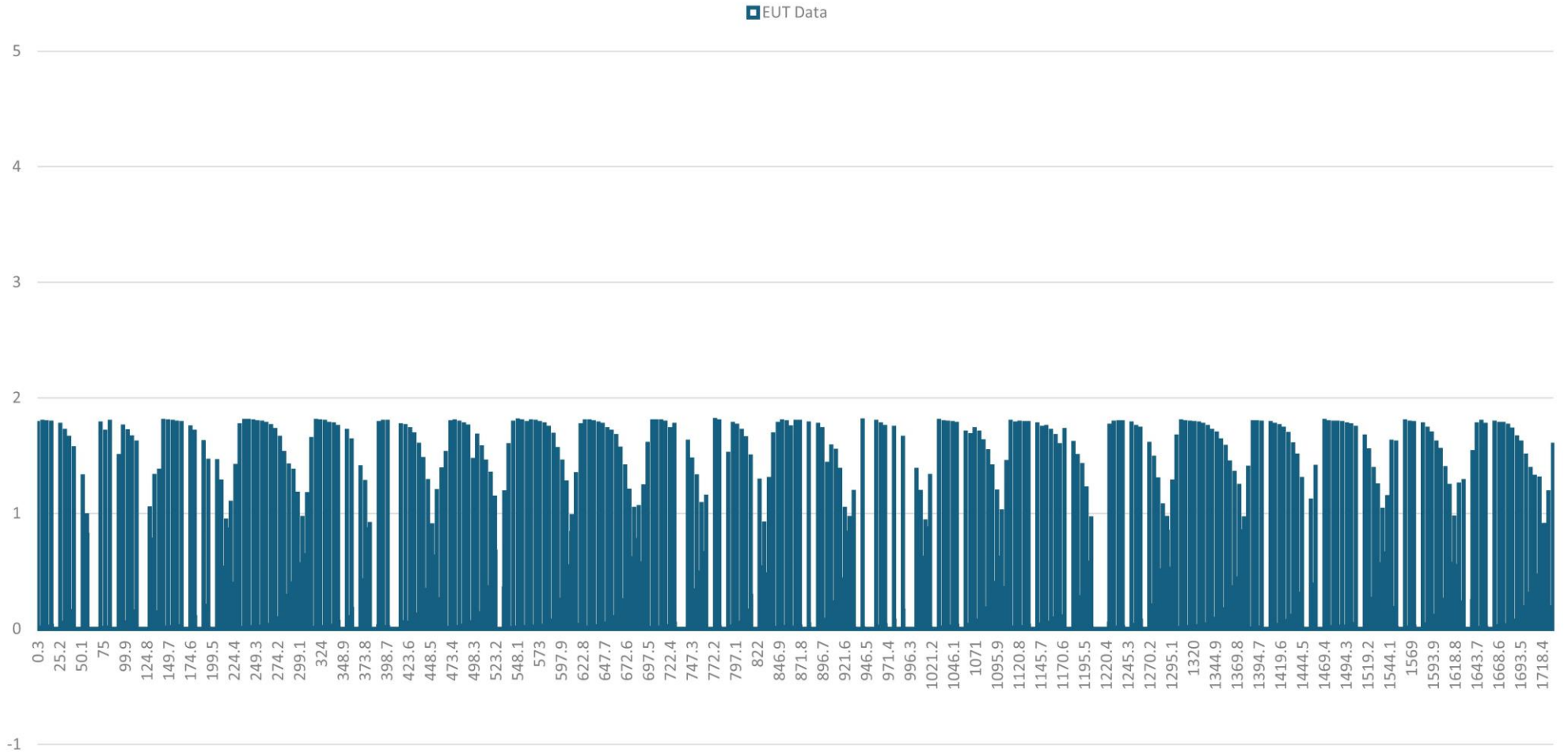

RS103 2.8-5GHz Horizontal Excel Plot



Company: Product Management Office, Air Warrior
Model Tested: OPC-M2
Report Number: 28380
Project Number: 13049
Test: RS103, Electric Field Susceptibility

RS103 2.8-5GHz Vertical Polarization 200V/M

■ EUT Data

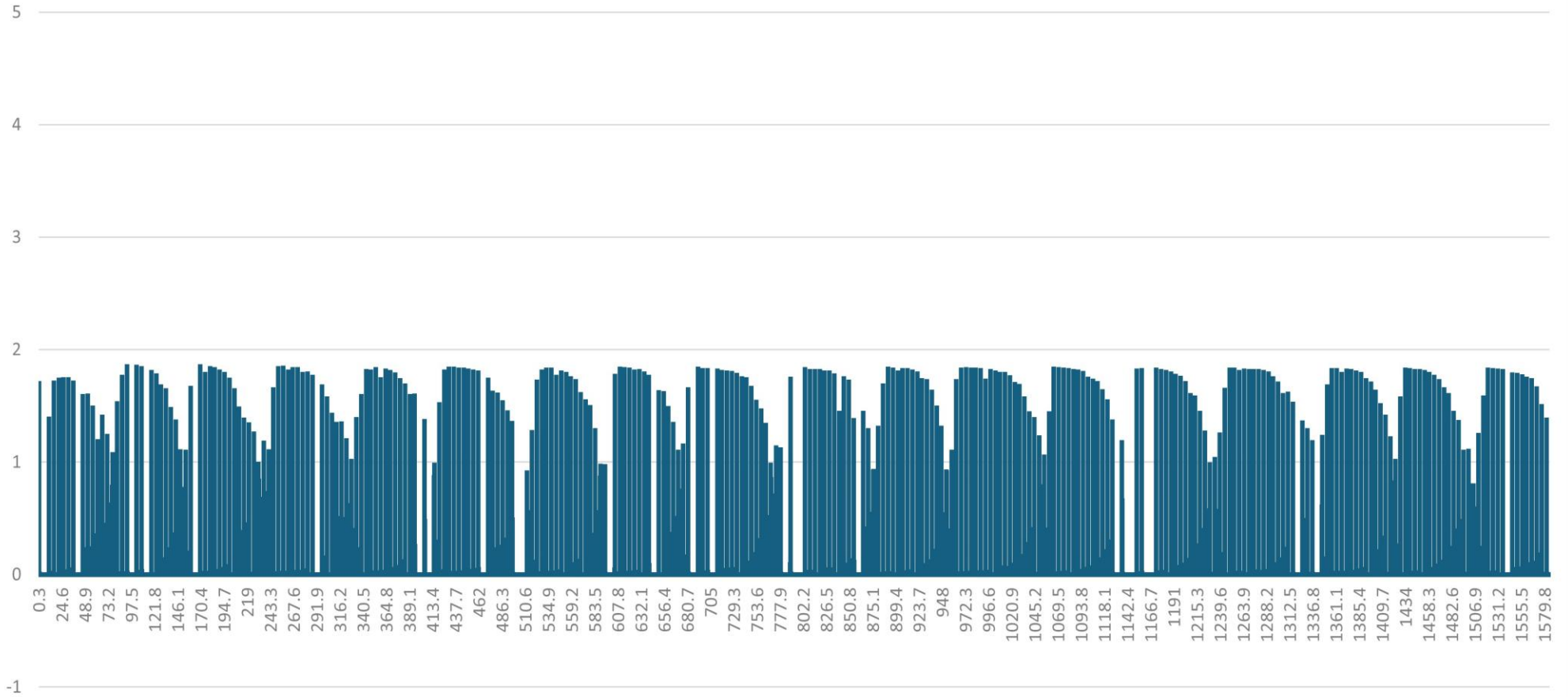

RS103 2.8-5GHz Vertical Excel Plot



Company: Product Management Office, Air Warrior
Model Tested: OPC-M2
Report Number: 28380
Project Number: 13049
Test: RS103, Electric Field Susceptibility

RS103 5-8GHz Horizontal Polarization 200V/M

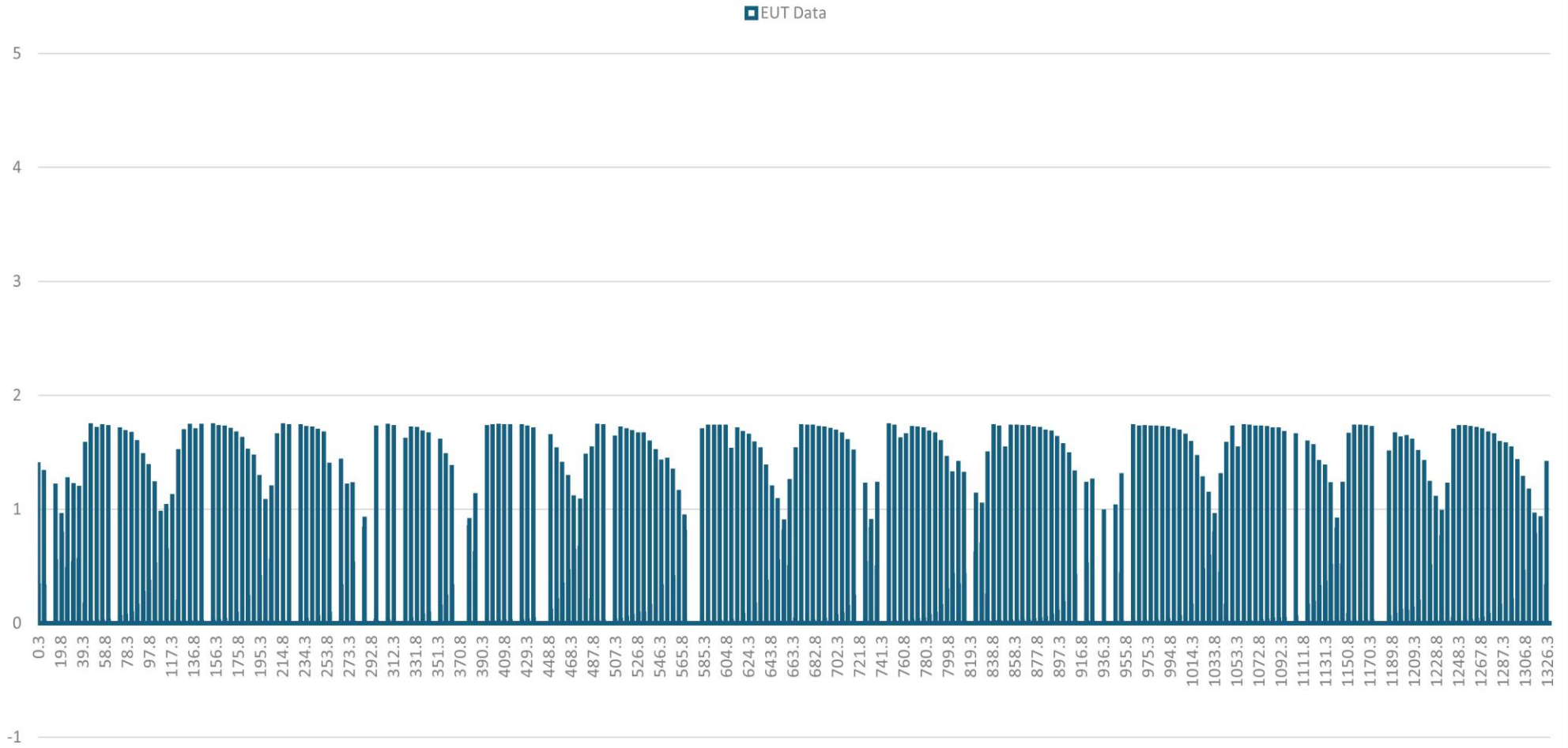

RS103 5-8GHz Horizontal Excel Plot



Company: Product Management Office, Air Warrior
Model Tested: OPC-M2
Report Number: 28380
Project Number: 13049
Test: RS103, Electric Field Susceptibility

RS103 5-8GHz Vertical Polarization 200V/M

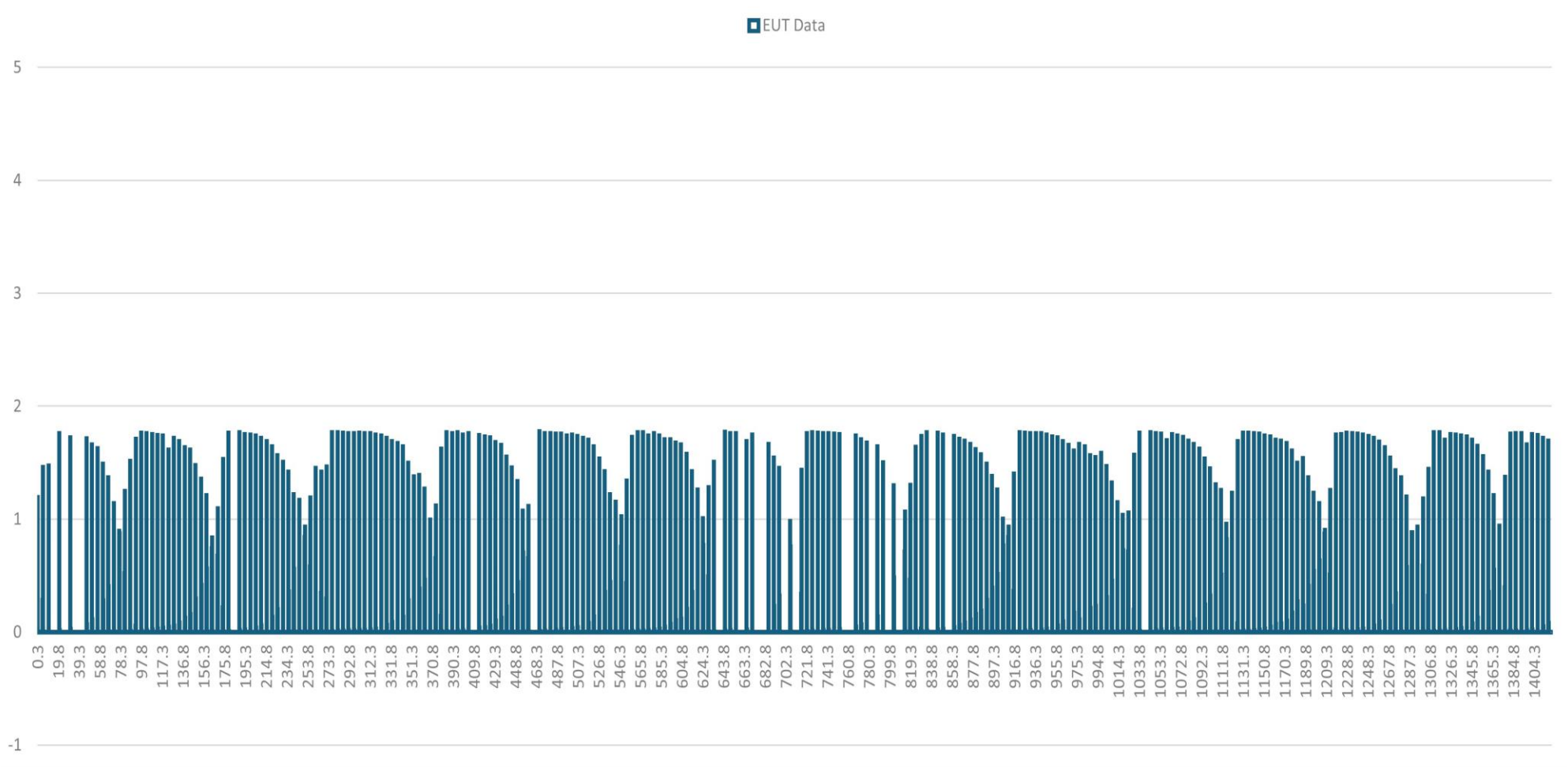

RS103 5-8GHz Vertical Excel Plot



Company: Product Management Office, Air Warrior
Model Tested: OPC-M2
Report Number: 28380
Project Number: 13049
Test: RS103, Electric Field Susceptibility

RS103 8-18GHz Horizontal 200V/M

■ EUT Data

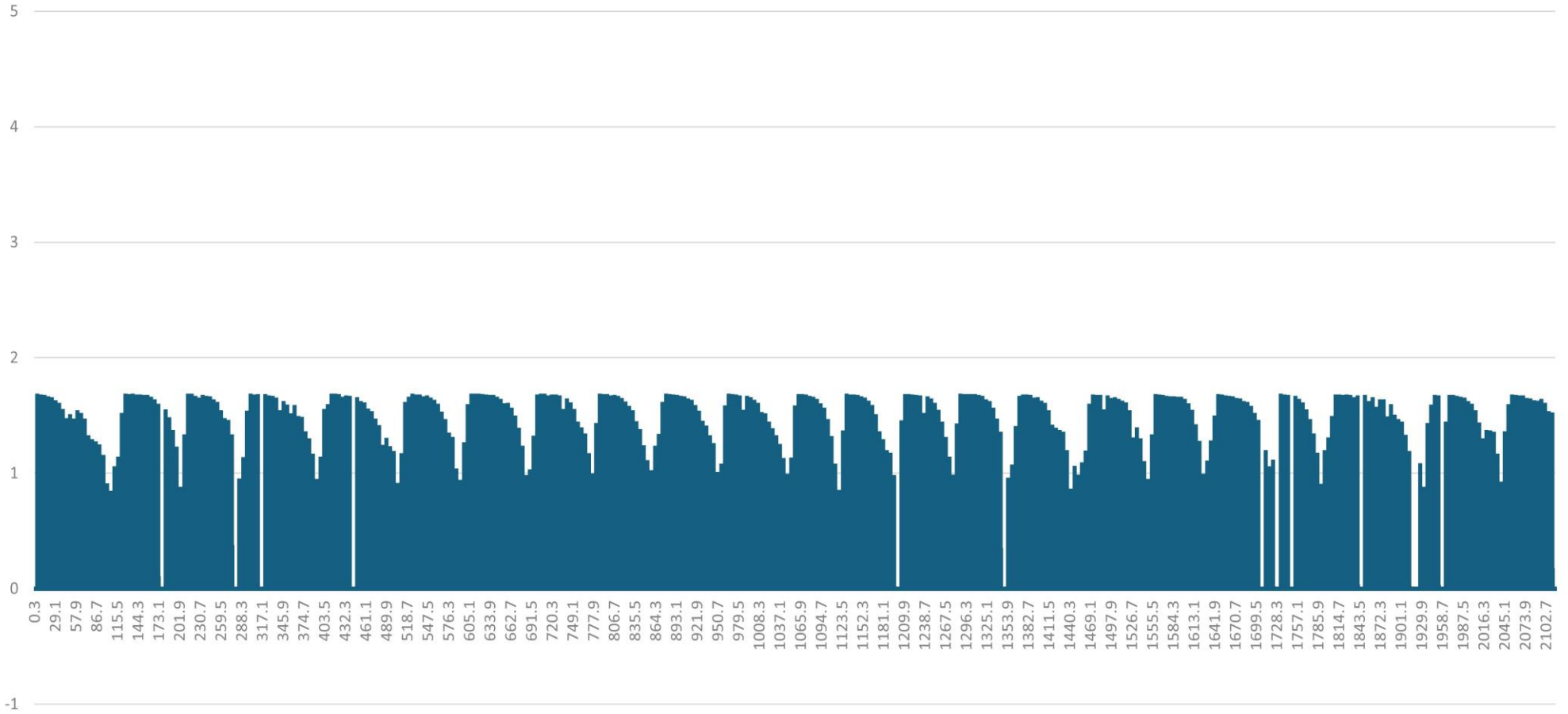

RS103 8-18GHz Horizontal Excel Plot



Company: Product Management Office, Air Warrior
Model Tested: OPC-M2
Report Number: 28380
Project Number: 13049
Test: RS103, Electric Field Susceptibility

RS103 8-18GHz Vertical Polarization 200V/M

■ EUT Data

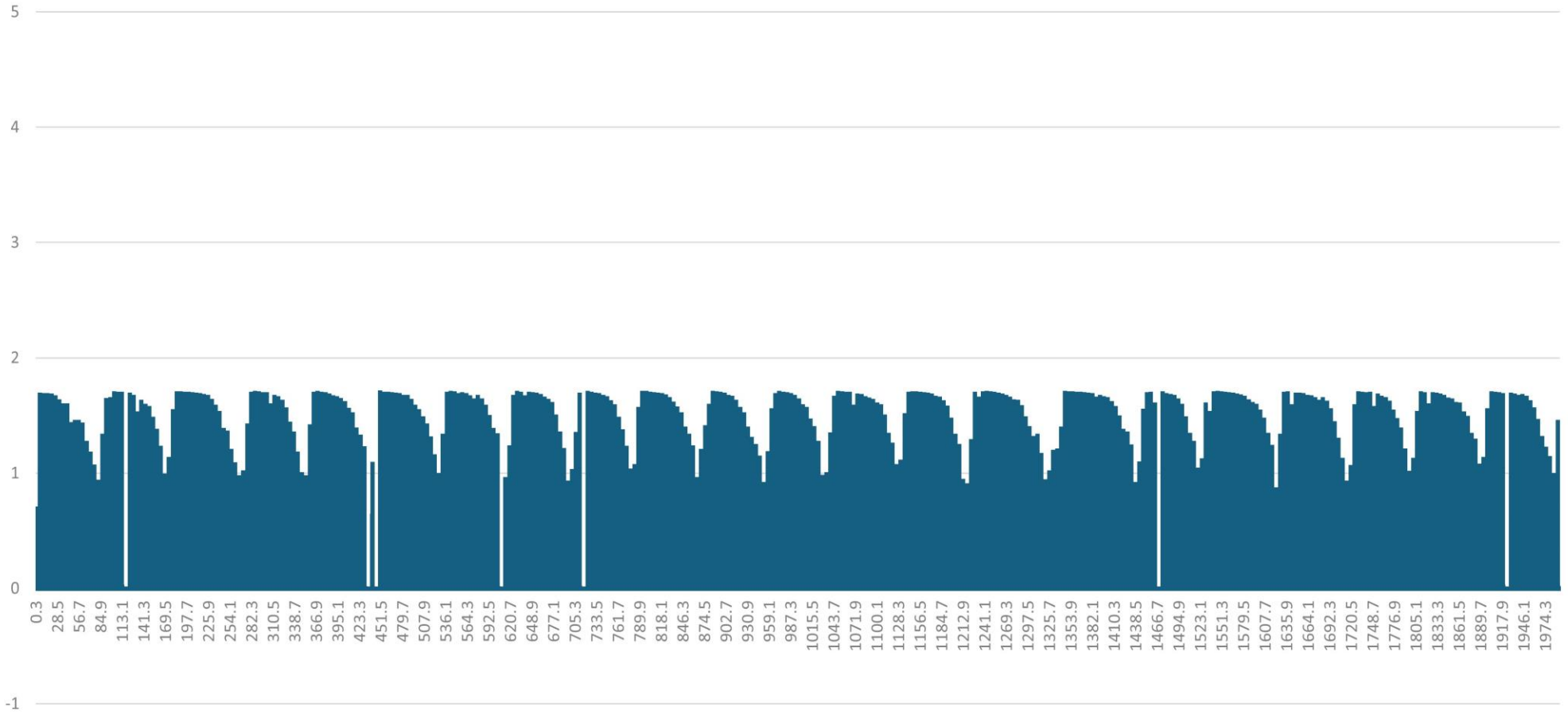

RS103 8-18GHz Vertical Excel Plot



Company: Product Management Office, Air Warrior
Model Tested: OPC-M2
Report Number: 28380
Project Number: 13049
Appendix A: QTP Redlines

APPENDIX A

MIL-STD-461G

QTP REDLINES

TEST PLAN: OPC-M2 EMI SOF TEST PLAN REV B 1.19.24 WITH
REDLINES



Company: Product Management Office, Air Warrior
Model Tested: OPC-M2
Report Number: 28380
Project Number: 13049
Appendix A: QTP Redlines

**Oxygen Pulse Controller OPC-M2
Electromagnetic Interference
Safety Of Flight
Qualification Test Plan**

Revision: DRAFT
January 2023

**Prepared By:
PMO, Air Warrior
6726 Odyssey Drive
Huntsville, AL 35806**

DISTRIBUTION STATEMENT D: Distribution authorized to the Department of Defense (DoD) and U.S. DoD contractors only, for administrative or operational use, as of 24 March 2017. Other requests **shall** be referred to: Product Manager (PM) Air Warrior (AW) ATTN: SFAE SDR-AW Redstone Arsenal, AL 35898-5000.

UNCLASSIFIED

DLS



Company: Product Management Office, Air Warrior
Model Tested: OPC-M2
Report Number: 28380
Project Number: 13049
Appendix A: QTP Redlines

OPC-M2 EMI SOF Qualification Test Plan

Rev DRAFT
4 January 2023

This page intentionally left blank.

UNCLASSIFIED
Distribution Statement D See Cover Page
ii



Company: Product Management Office, Air Warrior
 Model Tested: OPC-M2
 Report Number: 28380
 Project Number: 13049
 Appendix A: QTP Redlines

OPC-M2 EMI SOF Qualification Test Plan

Rev DRAFT
 4 January 2023

Change History

This sheet is a record of each issue of this document.

When the revised document is issued, the previous issue is automatically superseded.

Version	Date	Configuration Management	Explanation of Changes	Change Request
Rev DRAFT	4 January 2023	Mark Murray	N/A	Initial Release
Document Title: OPC-M2 EMI SOF Qualification Test Plan			Document Number: N/A	

UNCLASSIFIED

Distribution Statement D See Cover Page

iii



Company: Product Management Office, Air Warrior
Model Tested: OPC-M2
Report Number: 28380
Project Number: 13049
Appendix A: QTP Redlines

OPC-M2 EMI SOF Qualification Test Plan

Rev DRAFT
4 January 2023

This page intentionally left blank.

UNCLASSIFIED

Distribution Statement D See Cover Page

iv



TABLE of CONTENTS

1 INTRODUCTION AND OVERVIEW1

1.1 TEST APPROACH.....2

1.2 OPC-M2 ACCEPTANCE TEST PROCEDURES (ATP) AND OPERATIONAL TESTING2

1.3 US GOVERNMENT TEST WITNESS.....3

1.4 TEST UNIT ALLOCATION3

1.5 TEST DURATION.....3

1.6 SECURITY3

1.7 REQUIREMENT VERIFICATION DEFINITIONS4

1.8 APPLICABLE DOCUMENTS.....4

1.8.1 Test Plan Appendices4

2 MASTER TEST LIST6

2.1 ELECTROMAGNETIC PERFORMANCE6

2.1.1 Test Description6

2.1.2 Electromagnetic Requirements6

2.1.3 Parameters.....7

2.1.4 Special Tests7

2.1.5 Test Classification Category7

2.1.6 Test Approach, Objective, and Tests7

2.1.7 Test Equipment7

2.1.8 Support Equipment7

2.1.9 Special Test Equipment7

2.1.10 Electromagnetic Test Configuration.....7

2.1.11 Instrumentation **Error! Bookmark not defined.**

2.1.12 Data Reduction and Analysis8

2.1.13 Government Test Facilities8

2.1.14 Validation Procedure.....8

2.1.15 Test Witness9

2.1.16 Test Status9

2.1.17 Laboratory Test Log9

2.1.18 Data Sheets9

2.1.19 Record of the Test Equipment.....9

2.1.20 Photographs10

2.2 RE102, RADIATED EMISSIONS, ELECTRIC FIELD, 10 KHZ TO 18 GHZ10

2.2.1 Description.....10

2.2.2 Purpose10

2.2.3 Specificaiton Limits.....10

2.2.4 Test Setup10

2.2.5 Test Equipment10

2.2.6 Operating Mode10

2.2.7 Procedures.....12

2.2.8 Calibration (System Path Check).....12

2.2.9 RE102 Testing (Measurement).....13

2.3 RS103 - RADIATED SUSCEPTIBILITY, ELECTRIC FIELD, 2MHZ TO 10GHZ17

2.3.1 EUT Susceptibility Test Failure Criteria17

2.3.2 Antenna Placement for Radiated Susceptibility Measurement.....17

UNCLASSIFIED

Distribution Statement D See Cover Page

v



OPC-M2 EMI SOF Qualification Test Plan

Rev DRAFT
 4 January 2023

2.3.3	Electromagnetic Field Sensors Positioning	17
2.3.4	Susceptibility Testing	17
2.3.4.1	Frequency Scanning.....	17
2.3.4.2	Modulation of Susceptibility Signals.....	18
2.3.5	Thresholds of Susceptibility	19
2.3.6	Measuring Frequencies	19
2.3.7	Test Failure Procedure	19
2.3.8	Failure Report	19
2.3.9	EUT Installation.....	19
2.3.10	EMI Filter Panel	19
2.3.11	Polarization.....	20
2.3.12	Ground Plane	22
2.3.13	Instrumentation.....	22
2.3.14	Test Tolerances and Conditions.....	22
2.3.15	Test Equipment.....	22
2.3.16	Test Set-up.....	22
2.3.17	Test Procedure	23
2.3.17.1	Test Procedure	23
2.3.17.2	Calibration Procedure	23
2.3.18	OPC-M2 Testing Procedure	24
2.3.19	Radiated Susceptibility RS103 Test Results Format Example.....	25
2.3.20	Test Equipment Example List	26
2.3.21	Test Results.....	26

3	APPENDIX A – OPC-M2 OPERATIONAL TESTING AND ACCEPTANCE TEST PROCEDURE (ATP) EXECUTION	29
3.1	OPC-M2 OPERATIONAL TEST.....	29
3.1.1	Equipment/Cables Required (per OPC-M2 under Test).....	29
3.1.2	OPC-M2 Operational Test Procedure.....	29
3.1.3	OPC-M2 Acceptance Test Procedure	29
3.1.4	OPC-M2 Pass/Fail Criteria.....	30
3.2	OPC-M2 Acceptance Test Procedures (ATP).....	30

FIGURES

<u>Title</u>	<u>Page</u>
Figure 1-1: OPC-M2 Interface Block Diagram.....	1
Figure 1-2: PHODS Soldier Interface	2
Figure 2-1: General Electromagnetic Test Configuration.....	8
Figure 2-2: MIL-STD-461G, FIGURE RE102-3 LIMITS.....	11
Figure 2-3: RE102 General Test Setup.....	14
Figure 2-4: RE102 Antenna Setup	15
Figure 2-5: Data Sheet for RE102 Emission Test	16
Figure 2-6: RS103 Multiple Antenna Location for Frequency > 200MHz	20
Figure 2-7: RF Absorber Loading Diagram and Spacing Requirements	21
Figure 2-8: RS103 Calibration Test Setup.....	24
Figure 2-9: RS103 Setup	25

UNCLASSIFIED

Distribution Statement D See Cover Page



TABLES

<u>Title</u>	<u>Page</u>
Table 1-1: Qualification Test Unit Allocation.....	3
Table 1-2: Test Schedule for Qualification Testing.....	3
Table 1-3: Requirement Verification Definitions	4
Table 1-4: Reference Documents	4
Table 1-5: Test Plan Appendices	4
Table 2-1: Electromagnetic Qualification Definition Table	6
Table 2-2: Random Vibration	12
Table 2-3: Vibration Breakpoint Profile.....	18
Table 2-4: Susceptibility Scanning	18
Table 2-5: Electric Field Level and Modulation Type.....	18
Table 2-6: Test Results Example Format	25
Table 2-7: RS103 Example Test Equipment and Accessories	26
Table 2-8: An Example of Modulation Correction Factors	26
Table 2-9: An Example of RS103 Test Results Data.....	28

UNCLASSIFIED

Distribution Statement D See Cover Page

vii



1 Introduction and Overview

This document defines the plan for electromagnetic safety of flight only qualification of the Oxygen Pulse Controller, part number OPC-M2, herein referred to as the OPC-M2. The Portable Helicopter Oxygen Delivery System (PHODS) is a man-mounted oxygen delivery system that can be attached directly to a crew member's Survival Vest and helmet to support flight and ground missions at high altitudes. The 3 main components of the basic system are: (1) a regulator and oxygen cylinder; (2) an automatic oxygen pulse controller (OPC M2) with inlet and outlet hoses; (3) a flexible nasal cannula with a Q.D. coiled hose assembly. The oxygen cylinder is a Department of Transportation (DOT) certified steel cylinder that is placed in a pocket made from fire resistant material that is attached to the crew member's Survival Vest. Oxygen is delivered from the cylinder via a regulator to the OPC M2 unit powered by 2 AA batteries. The OPC M2 automatically provides a predetermined amount of oxygen when it senses a pressure differential caused by the user's breathing and contains an internal barometer that detects changes in altitude. When the system is turned on, it will become active at $8,000 \pm 500$ feet (ft.) pressure altitude (PA) and will start to deliver measured quantities of oxygen to the crew member between 8,000 ft. PA to 10,000 ft PA. The OPC M2 will continue to deliver oxygen up to 18,000 ft. MSL. When the aircraft altitude drops below $8,000 \pm 500$ ft. PA, the unit will de-activate. A PHODS mask may be used in lieu of the nasal cannula when operational and individual physiology conditions dictate. However, the mask is not recommended for routine high altitude operations since this configuration will consume the limited quantity of oxygen provided by the basic PHODS at an increased rate. PHODS has been tested and approved for use on US Army Chinook (CH-47), Blackhawk (UH-60) and Apache (AH-64) aircraft.

A general block diagram of the EUT connection with other equipment in the airframe is presented in the Figures below.

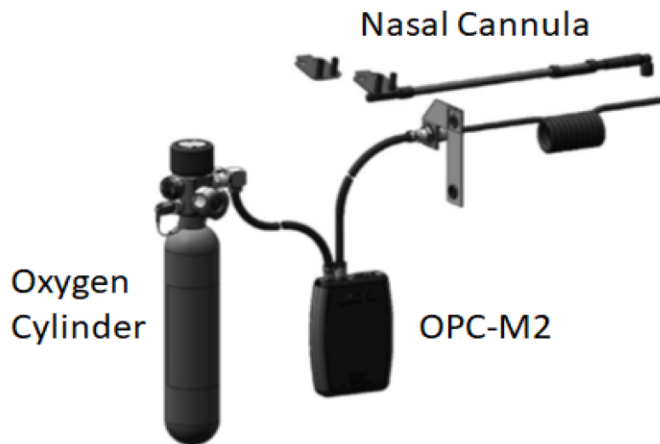

Figure 1-1 - OPC-M2 Interface Block Diagram



The OPC-M2 is mounted to the user in a nomex pocket on the flight vest. The oxygen bottle is mounted on the side. The cannula gets pulsed oxygen from the OPC-M2 when an inhalation event is detected. There is no bonding of the OPC-M2 to the user or the airframe. The external case of the OPC-M2 is plastic.

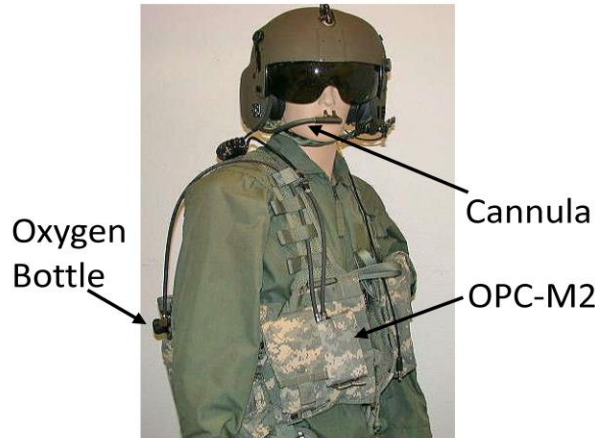

Figure 1-2 - PHODS Soldier Interface

The goal of this SoF qualification effort is to satisfy minimum SoF electromagnetic requirements to allow the OPC-M2 to be evaluated on the aircraft for demonstrations and design verification test.

1.1 Test Approach

This SoF EMI qualification testing will verify the OPC-M2 against the requirements set forth in the Air Soldier AQP, TN98729E. Testing will be conducted at certified testing laboratories as identified herein. Specific qualification tests will be conducted in accordance with (IAW) MIL-STD-461G to ensure the required performance as specified in the Air Soldier AQP, TN98729E are met. Qualification testing will be conducted using dedicated production representative, qualification OPC-M2 hardware units.

1.2 OPC-M2 Acceptance Test Procedures (ATP) and Operational Testing

The Acceptance Test Procedures (ATP) and Operational Testing (OT) procedures are provided in Appendix A of this document. The ATP will be conducted on the OPC-M2 before and after completion of each electromagnetic test series the individual unit is scheduled to complete (e.g. After completion of all Combined Environment test cycles). The successful ATP at the end of a test series, IAW Appendix A, will serve as the entrance Acceptance for the next test series. This will verify that no degradation has occurred because of electromagnetic testing. The operational exercise of the OPC-M2 (using OT procedures) will be conducted during specified tests as specified in this test plan. The operational testing is identified in Appendix A and includes procedure steps to monitor system operation during test as required.

UNCLASSIFIED

Distribution Statement D See Cover Page

2



1.3 US Government Test Witness

US Army (USA) and Aviation Engineering Directorate (AED) representation may participate as witnesses during testing. US Government representatives will be provided at least 10 working days notice prior to start of testing if test events deviate from schedule. If tests are on conducted per schedule, no notification will be provided other than furnishing a schedule prior to start of test.

1.4 Test Unit Allocation

Table 1-1: Qualification Test Unit Allocation

Asset	Qualification Test	Support Hardware
OPC-M2 #1	EMI Performance	1. PHODS Oxygen Cylinder with Regulator, Nasal Cannula, Tubing 2. Oxygen Detector 3. Operational Test Equipment (cables, computers, and test box) 4. Test Chambers/Facilities 5. Electromagnetic Test Hardware

1.5 Test Duration

Table 1-2 depicts the schedule for the Qualification testing.

Table 1-2: Test Schedule for Qualification Testing

Asset	Qualification Test	Duration (Days)
OPC-M2 #1	Electromagnetic Test Performance	17

1.6 Security

All Qualification hardware and testing will be unclassified.

UNCLASSIFIED

Distribution Statement D See Cover Page



1.7 Requirement Verification Definitions

Table 1-3 identifies the methods to be utilized for the verification of requirements as stipulated in this plan.

Table 1-3: Requirement Verification Definitions

Method	Description
Analysis	Involves a technical evaluation of design information such as equations, charts, graphs, drawings, schematics, and other data. If actual tests were conducted for a related or unrelated purpose, and utilization of these data will prove that requirement has been met, it should be considered "analysis". Analysis methods include the use of modeling and simulation with a government-accredited model.
Demonstration	Observable functional operation, under controlled conditions not requiring subsequent analysis of data, is used to verify that a given requirement is met.
Examination	An element of verification and inspection consisting of investigation, without the use of special laboratory appliances or procedures, of items to determine conformance to those specified requirements which can be determined by such investigations. Inspection is generally nondestructive, and typically includes the use of sight, hearing, smell, touch, and taste; simple physical manipulation; mechanical and electrical gauging and measurement; and other forms of investigation.
Test	Involves observation or recording of data during operation of an item. Where "test" is the designated verification method, it is understood that some degree of analysis is inherent in the verification process.

In addition, select requirements will be verified by "Similarity". These specific requirements are identified in Section 2 and Section 3 of this plan.

1.8 Applicable Documents

Table 1-4: Reference Documents

MIL-STD-461G (CHG-1)	REQUIREMENTS FOR THE CONTROL OF ELECTROMAGNETIC INTERFERENCE CHARACTERISTICS OF SUBSYSTEMS AND EQUIPMENT
----------------------	--

1.8.1 Test Plan Appendices

For simplicity all appendices are referenced in Table 1-5: Test Plan Appendices.

Table 1-5: Test Plan Appendices

App #	Title	Document Description
Appendix A	OPC-M2 Test Mode	Operating the OPC-M2 in Test Mode and OPC-M2 Acceptance Test Procedure

UNCLASSIFIED

Distribution Statement D See Cover Page



Company: Product Management Office, Air Warrior
Model Tested: OPC-M2
Report Number: 28380
Project Number: 13049
Appendix A: QTP Redlines

OPC-M2 EMI SOF Qualification Test Plan

Rev DRAFT
4 January 2023

App #	Title	Document Description
		The OPC-M2 Acceptance Test Procedure (ATP) is an informal procedure for verifying operation of the OPC-M2 following testing to ensure inhalation events still trigger oxygen delivery at the base altitude of the test facility

UNCLASSIFIED

Distribution Statement D See Cover Page



2 Master Test List

2.1 Electromagnetic Performance

2.1.1 Test Description

This test category is to verify the electromagnetic performance of the OPC-M2 unit. All required Safety of Flight (SOF) requirements and the verification methods are identified in section 2.1.2 below.

2.1.2 Electromagnetic Requirements

Full qualification electromagnetic requirements IAW the Air Soldier AQP, TN 98729E are listed below in Table 2-1 with Safety of Flight (SOF) requirements identified by the SOF requirement column.

Table 2-1: Electromagnetic Qualification Definition Table

Requirement	Description	First Flight (flight/safety critical)	First Flight
CE101	Conducted Emissions, Power Leads, 30 Hz to 10 kHz	X	N/A
CE102	Conducted Emissions, Power Leads, 10 kHz to 10 MHz	X	N/A
CE106	Conducted Emissions, Antenna Terminal, 10 kHz to 40 GHz	X	N/A
CS101	Conducted Susceptibility, Power Leads, 30 Hz to 150 kHz	X	
CS114	Conducted Susceptibility, Bulk Cable Injection, 10 kHz to 200 MHz	X	
CS115	Conducted Susceptibility, Bulk Cable Injection, Impulse Excitation	X	
CS116	Conducted Susceptibility, Damped Sinusoidal Transients, Cables and Power Leads, 10 kHz to 100 MHz		
RE101	Radiated Emissions, Magnetic Field, 30 Hz to 100 kHz		
RE102	Radiated Emissions, Electric Field, 10 kHz to 18 GHz	X	X
RE103	Radiated Emissions, Antenna Spurious and Harmonic Outputs, 10 kHz to 40 GHz	Required if CE106 cannot be completed	
RS101	Radiated Susceptibility, Magnetic Field, 30 Hz to 100 kHz		
RS103	Radiated Susceptibility, Electric Field, 2 MHz to 40 GHz	X (Note 1)	X Required for Safety of Flight Equipment

UNCLASSIFIED
 Distribution Statement D See Cover Page



2.1.3 Parameters

Tests are activities that result in collecting measurable data. The EMI data to be verified, with tolerances, are defined in each applicable verification procedures

2.1.4 Special Tests

None.

2.1.5 Test Classification Category

The test classification category is Electromagnetic Test IAW MIL-STD-461G.

2.1.6 Test Approach, Objective, and Tests

Entrance criteria to each test series requires failure free Operational testing. Operational testing will be performed at the conclusion of each test series, and shall be failure free. Success criteria for each verification are described in the detailed verification procedures.

2.1.7 Test Equipment

All necessary test equipment is identified in the referenced verification procedures.

2.1.8 Support Equipment

Each test series requires unique equipment, and this equipment is available and defined in the detailed verification procedures. The test report shall provide a list of all test support equipment used and calibration dates.

2.1.9 Special Test Equipment

None.

2.1.10 Test Configuration

The general test configuration is identified below in Figure 2-1. When the OPC-M2 is switched from the "OFF" position to the "F/20" position, the device will deliver oxygen from the PHODS bottle until the batteries die or the bottle runs out of oxygen. A pulse of oxygen delivery to the oxygen meter demonstrates proper operation for the duration of the test. The oxygen meter and oxygen bottles are test support items, not test items. OPC-M2 battery life is approximate 10 hours. From the time the small oxygen cylinder is full (meter is touching green) to empty (meter is touching red), the unit will run for approximately three hours. When full, oxygen pulses recorded by the meter are approximately 2 lpm, while as it approaches the red position, pulses are approximately at 1.3 lpm. So long as the OPC-M2 continues to deliver oxygen, the amount isn't important to be considered successfully operating.

The oxygen meter available from the Government supports data logging through a proprietary software package. Trial operation of the logging software only works for 60 days. If the vendor requires more than 60 days to perform all bench testing and chooses to use the Government furnished oxygen meter, a license for the software will have to be purchased to enable logging of oxygen delivery.

UNCLASSIFIED

Distribution Statement D See Cover Page

7



Figure 2-1: General Electromagnetic Test Configuration

2.1.11 Instrumentation

Specialized test equipment will be defined in the test report. Test data sheets will be utilized to record all test results.

2.1.12 Data Reduction and Analysis

Not required.

2.1.13 Government Test Facilities

Not required.

2.1.14 Validation Procedure

The validation procedure will verify that all test equipment, tables, and sensors to be used for this test series are within calibration. At the conclusion of each test series, all logged data will be reviewed to verify that there were no excursions from the required test profile.

2.1.15 The anechoic test chamber shall have Radio Frequency (RF) absorbing material (carbon impregnated foam pyramids) backed by ferrite material on the back wall, the front wall, the sides, and the

UNCLASSIFIED

Distribution Statement D See Cover Page

8



ceiling to reduce reflections of electromagnetic energy and to improve accuracy and repeatability. The EMI chamber shall meet the ambient requirements of MIL-STD-461G, paragraph 4.3.4.

2.1.15 Test Witness

The test laboratory shall notify the customer so that an engineering representative may witness performance of tests. The customer shall be notified of the test location at least 48 hours in advance of the start of each test. If the customer declines to witness any specific test, this shall be accepted as a concession of attendance and as authorization for the test laboratory to be the sole certifier of test performance.

The laboratory test engineer is performing the following functions:

- a. Approve the test setup prior to the start of testing.
- b. Authorize the start and stop of any specified test.
- c. Ensure that the laboratory test log is properly updated.
- d. Approve the use of equivalent testing equipment such as receiver instead of spectrum analyzer. Under the circumstances full details of the measurement procedure will be reported in the test report.

2.1.16 Test Status

Each engineering and qualification test shall be documented. The test engineer records either the successful completion, or if unsuccessful, details the trouble symptom. The test engineer is responsible for ensuring the analysis and corrective action sections are completed before testing resumes.

2.1.17 Laboratory Test Log

The test engineer is responsible to maintain a chronological record of the test program on laboratory test log notebook. Any information pertinent to the test program, such as setup details, test progress, troubles, troubleshooting information, etc., are recorded in the Test Log.

2.1.18 Data Sheets

The test engineer as required by each test shall complete data sheets. Indication of "Pass/Fail" shall be noted on each data sheet.

2.1.19 Record of the Test Equipment

Test equipment used are shall document the following:

- a. Equipment nomenclature and calibration due date.
- b. Bandwidth and scanning speeds of measurements receivers.
- c. The characteristics of coupling transformers and band reject filters.
- d. Antenna factor of specified antennas and transfer impedance of current probes.
- e. Description of the software being used.

UNCLASSIFIED

Distribution Statement D See Cover Page

9



2.1.20 Photographs

Photographs shall record the equipment and test setup, as applicable, for each qualification test and be included in the test report. In addition, other pertinent information that can best be recorded by photograph shall be done so.

2.2 RE102, RADIATED EMISSIONS, ELECTRIC FIELD, 10 kHz TO 18 GHz

2.2.1 DESCRIPTION.

Test Method RE102 will measure the electric field (E-field) electromagnetic radiation emitted by the OPC-M2 over the frequency range of 10 kHz to 18 GHz.

2.2.2 PURPOSE.

The purpose of this test is to confirm that the OPC-M2 E-field emissions have been controlled to the required limits so that the performance of the sensitive equipment, (e.g., communications receivers, etc.), is not impaired.

2.2.3 SPECIFICATION LIMITS.

As detailed in Figure 2-2, the applicable limits for the Oxygen Pulse Controller are the standard boundaries of MIL-STD-461G, FIGURE RE102-3, for equipment installed in "Fixed Wing External or Helicopters".

2.2.4 TEST SETUP.

Photograph 1, Figure 2-3 and Figure 2-4 detail the test setups that will be employed.

2.2.5 TEST EQUIPMENT.

Example test equipment that can be utilized for the RE102 Test effort is listed in Table 2-2. This equipment or its equivalent can be used to perform RE102 testing. The test report shall document actual test equipment used to perform testing and provide calibration dates per Table 2-2 format.

2.2.6 OPERATING MODE.

Radiated emissions data will be obtained with the OPC-M2 operating in test mode as defined in paragraph 3.1.2. An additional measurement will be performed with the oxygen test meter on and off to determine if the test meter may contribute to the radiated emissions.

UNCLASSIFIED

Distribution Statement D See Cover Page

10



OPC-M2 EMI SOF Qualification Test Plan

Rev DRAFT
 4 January 2023

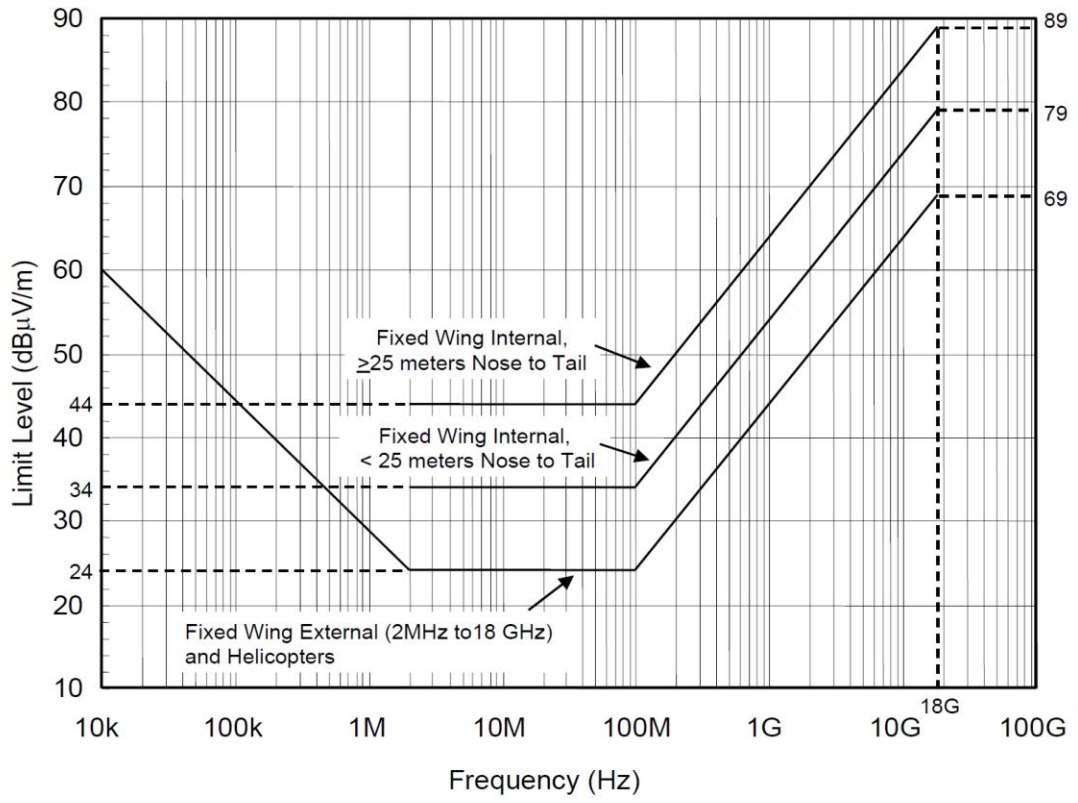

Figure 2-2: MIL-STD-461G, FIGURE RE102-3 LIMITS

UNCLASSIFIED

Distribution Statement D See Cover Page



OPC-M2 EMI SOF Qualification Test Plan

Rev DRAFT
 4 January 2023

Equipment	Manufacturer	Model Number	Asset# / Serial Number	Range
Verification Network	EMCO	3301CB	9802-3932	N/A
Counterpoise	EMCO	N/A	N/A	60 cm x 60 cm
Spectrum Analyzer	Agilent	e4440A	MY46180453	3Hz-26.5GHz
Rod Antenna	EMCO	3301C	00081111	30Hz - 50MHz
Biconical Antenna	Electro-Metrics	BIA-25C	2617	20MHz- 220MHz
Large Horn Antenna	EMCO	3106	2127	200MHz-2GHz
Small Horn Antenna	ETS-Lindgren	3117	00135193	1-18GHz
50Ω Cables	Pasternack	RG223U	Any	DC-1GHz
50Ω Cables	Teledyne Storm Products	MFR-5700	Any	1-18GHz
Signal Generator	Rhode & Schwarz	SML-01	100025	10kHz-1GHz
Signal Generator	Rhode & Schwarz	SMB-100A	Asset 661	1-40GHz
Pre-amplifier	Com-Power	PAM-118A	551115	1-18GHz
Antenna Continuity Check Antenna: bicon **	Electrometrics	BIA-25C	Any	20MHz-220MHz
Antenna Continuity Check Antenna: Horn **	EMCO	3106	Any	200-1000MHz
Antenna Continuity Check Antenna: Horn **	ETS-Lindgren	3115 or 3117	Any	1-18GHz

Table 2-2: Example RE102 Test Method Equipment

Note: Equivalent equipment may be used. The 10pF capacitor used for the system verification in the 10kHz - 30Mhz range is included in the EMCO 3301CB Verification Network.

Note: A list of test equipment used and applicable calibration dates will be included in the EMITR.

2.2.7 PROCEDURES.

The E-field emission testing will be performed one meter in front of the OPC-M2. The radiated emissions will be monitored and data recorded using the antennas (or equivalent) specified in Table 2-2. The raw test data shall be automatically corrected using the antenna correction factors along with preamp gain and cable loss. Above 30 MHz, the limits shall be met for both horizontally and vertically polarized E- fields. Tests will be made in the mode of operation as specified in Paragraph 6 above using the procedures of MIL-STD-461G and the following test techniques:

UNCLASSIFIED

Distribution Statement D See Cover Page



2.2.8 Calibration (System Path Check).

At the beginning of each emission test, the complete test system (including Measurement Receivers, cables, attenuators, couplers and so forth) is verified by injecting a known signal, as stated in the single test procedure, while monitoring system output for the proper indication.

2.2.9 RE102 Testing (Measurement).

Step #1.

Using Photograph 1, Figure 2-3 and Figure 2-4 as references, interconnect the EMI laboratory measurement antenna, coaxial cable, measuring and recording instrumentation of Table 2-2 (or equivalent test equipment).

Step #2.

The EMI laboratory measuring and recording instrumentation shall be connected to the AC power through separate isolation transformers to prevent the circulation of CM RF ground currents in the equipment.

Step #3.

Verify operation of the OPC-M2 in test mode per paragraph 3.1.2 and record results.

Step #4.

One test antenna location will be used to measure the OPC-M2 emissions.

Step #5.

Connect the spectrum analyzer or EMI receiver to the first test antenna.

Step #6.

Measure the E-field emissions across the applicable RE102 frequency range from 10 kHz to 18 GHz using the EMI measurement system with the OPC-M2 off (ambient scan). Then operate the OPC-M2 in accordance with Paragraph 3.1.2 of this appendix and record these emission measurements.

NOTE: EMITR data presentation shall be continuous and automatically plotted amplitude versus frequency profiles on X-Y axis outputs for the entire frequency range of the RE102 Requirement; i.e. 10 kHz to 18 GHz.

Step #7.

Save the measured data.

Step #8.

Change to the next frequency range and appropriate antenna.

Step #9.

UNCLASSIFIED

Distribution Statement D See Cover Page

13



Repeat the measurement steps (6) through (8) until all frequency ranges have been measured for the vertical polarization from 10 kHz to 18 GHz and for the horizontal polarization from 30 MHz to 18 GHz. Record the results on Data Sheet 1.

Step #10.

Upon completion of all testing, verify OPC-M2 operation per paragraph 3.1.3 and record results.

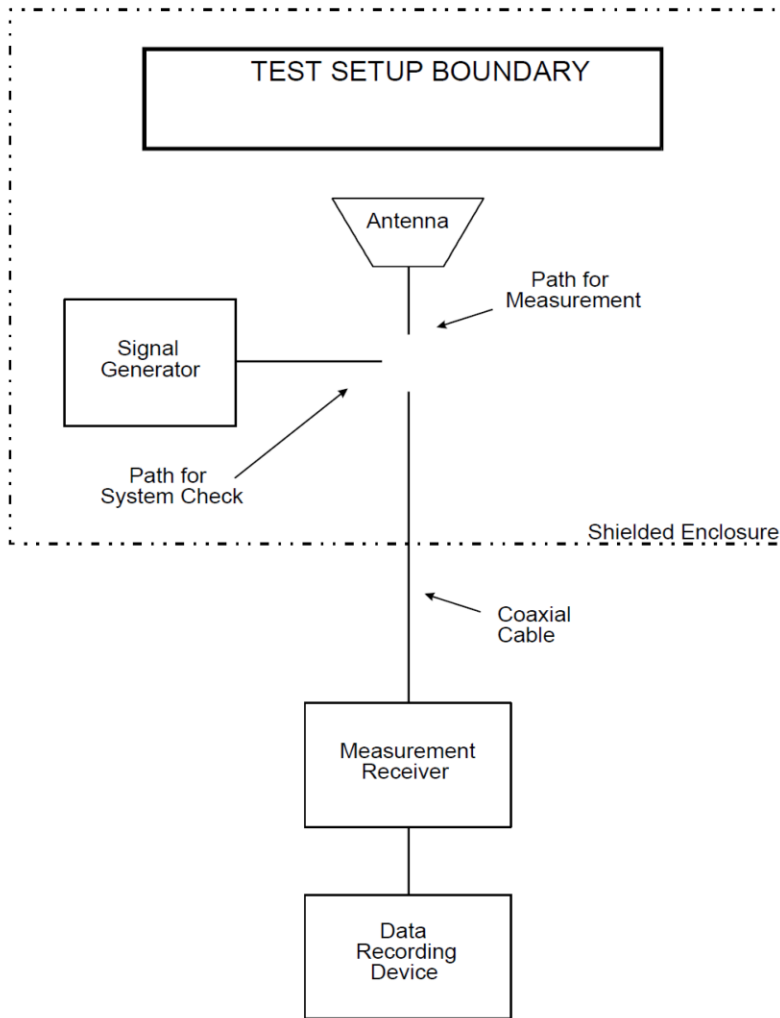

UNCLASSIFIED

Distribution Statement D See Cover Page

OPC-M2 EMI SOF Qualification Test Plan

Rev DRAFT
 4 January 2023

Figure 2-3: RE102 General Test Setup

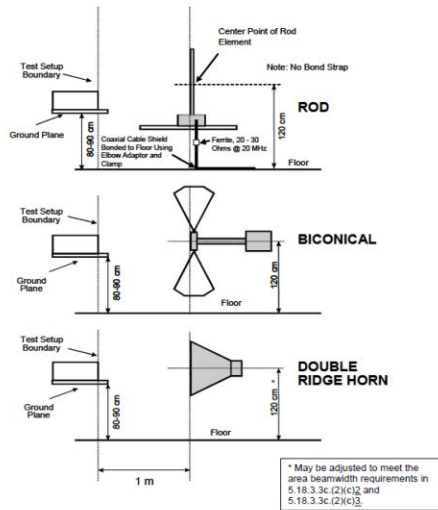

Figure 2-4 : RE102 Antenna Setup

UNCLASSIFIED

Distribution Statement D See Cover Page



Company: Product Management Office, Air Warrior
 Model Tested: OPC-M2
 Report Number: 28380
 Project Number: 13049
 Appendix A: QTP Redlines

OPC-M2 EMI SOF Qualification Test Plan

Rev DRAFT
 4 January 2023

Data Sheet 1: RE102 Test Results

Test Engineer:

Start Date:

Stop Date:

Equipment Nomenclature:

Serial Number:

Test Method:

Type of Measurement: (Check)

Conducted:

Radiated:

Measurement Point:

Mode of Operation:

Frequency Range of Test:

Measurement Technique:

Calibrated Current:

Calibrated Voltage:

Substitution:

Test Equipment Used:

Detector Function:

Peak:

Average:

Test Frequency	Complies With Limits		Emission Level Above Specification	Maximum Emission Level if Not Failure	Memo:
	Yes	No			
10 kHz – 150 kHz (vertical polarization)					
150 kHz - 30 MHz (vertical polarization)					
30 MHz - 200 MHz (vertical polarization)					
30 MHz - 200 MHz (horizontal polarization)					
200 MHz - 1 GHz (vertical polarization)					
200 MHz - 1 GHz (horizontal polarization)					
1 GHz - 2 GHz (vertical polarization)					
1 GHz - 2 GHz (horizontal polarization)					
2 GHz - 18 GHz (vertical polarization)					
2 GHz - 18 GHz (horizontal polarization)					

Figure 2-5 SAMPLE DATA SHEET FOR RE102 EMISSION TEST

UNCLASSIFIED

Distribution Statement D See Cover Page



2.3 RS103 - Radiated Susceptibility, Electric Field, 2 MHz to 10 GHz

2.3.1 EUT Susceptibility Test Failure Criteria

The OPC-M2 is considered “failed” if any of the following conditions per each test occur:

1. Failure to pass the ATP per paragraph 3.1.3 following a Susceptibility test.
2. The device ceases to deliver oxygen during test.
3. Error message from the OPC-M2 during test.

2.3.2 Antenna Placement for Radiated Susceptibility Measurement

For electric field radiated susceptibility measurements (RS103), the antenna positioning requirements are as follows:

Antennas shall be placed 1 meter from the test setup boundary as follows:

1. 10 kHz to 200 MHz:

Test setup boundaries less than or equal to 3 meters.

Center the antenna between the edges of the test setup boundary. The boundary includes all enclosures of the EUT and the 2 meters of exposed interconnecting and power leads.

Interconnecting leads shorter than 2 meters are acceptable when they represent the actual platform installation.

2. 200 MHz and above:

Multiple antenna position may be required. (See Figure 4-3). Determine the number of antenna positions (N) as follows:

- a. For testing from 200 MHz up to 1 G-Hz, place the antenna in a sufficient number of positions such that the entire width of each EUT enclosure and the first 35 cm of cables and leads interfacing with the EUT enclosure are within the 3 dB beam-width of the antenna.

- b. For testing at 1 GHz and above, place the antenna in a sufficient number of positions such that the entire width of each EUT enclosure and the first 7 cm of cables and leads interfacing with the EUT enclosure are within the 3 dB beam-width of the antenna.

2.3.3 Electromagnetic Field Sensors Positioning

Position sensors 1 meter from and directly opposite the transmit antenna as shown in [Figure 2-6](#) and a minimum of 30 cm above the ground plane. Do not place sensors directly at corners or edges of EUT components.

2.3.4 Susceptibility Testing

2.3.2 Frequency Scanning

For susceptibility measurements, the entire frequency range for each applicable test is scanned. For swept frequency susceptibility testing, frequency step sizes of signal sources do not exceed the values listed in Table 2-4. The step sizes are specified in terms of a multiplier

UNCLASSIFIED

Distribution Statement D See Cover Page

17



2.3 RS103 - Radiated Susceptibility, Electric Field, 2 MHz to 10 GHz

2.3.1 EUT Susceptibility Test Failure Criteria

The OPC-M2 is considered “failed” if any of the following conditions per each test occur:

1. Failure to pass the ATP per paragraph 3.1.3 following a Susceptibility test.
2. The device ceases to deliver oxygen during test.
3. Error message from the OPC-M2 during test.

2.3.2 Antenna Placement for Radiated Susceptibility Measurement

For electric field radiated susceptibility measurements (RS103), the antenna positioning requirements are as follows:

Antennas shall be placed 1 meter from the test setup boundary as follows:

1. 10 kHz to 200 MHz:

Test setup boundaries less than or equal to 3 meters.

Center the antenna between the edges of the test setup boundary. The boundary includes all enclosures of the EUT and the 2 meters of exposed interconnecting and power leads.

Interconnecting leads shorter than 2 meters are acceptable when they represent the actual platform installation.

2. 200 MHz and above:

Multiple antenna position may be required. (See Figure 4-3). Determine the number of antenna positions (N) as follows:

- a. For testing from 200 MHz up to 1 G-Hz, place the antenna in a sufficient number of positions such that the entire width of each EUT enclosure and the first 35 cm of cables and leads interfacing with the EUT enclosure are within the 3 dB beam-width of the antenna.

- b. For testing at 1 GHz and above, place the antenna in a sufficient number of positions such that the entire width of each EUT enclosure and the first 7 cm of cables and leads interfacing with the EUT enclosure are within the 3 dB beam-width of the antenna.

2.3.3 Electromagnetic Field Sensors Positioning

Position sensors 1 meter from and directly opposite the transmit antenna as shown in **Figure 2-6** and a minimum of 30 cm above the ~~ground plane~~. Do not place sensors directly at corners or edges of EUT components.

NON-CONDUCTIVE TABLE

2.3.4 Susceptibility Testing

Amc 2/27/2024

2.3.2 Frequency Scanning

For susceptibility measurements, the entire frequency range for each applicable test is scanned. For swept frequency susceptibility testing, frequency step sizes of signal sources do not exceed the values listed in Table 2-4. The step sizes are specified in terms of a multiplier

UNCLASSIFIED

Distribution Statement D See Cover Page

17



OPC-M2 EMI SOF Qualification Test Plan

Rev DRAFT
 4 January 2023

of the tuned frequency (f_0) of the signal source. Stepped scans refer to signal sources that are sequentially tuned to discrete frequencies. Stepped scans shall dwell at each tuned frequency for a minimum of 3 seconds.

Frequency Range	6dB Bandwidth	Dwell Time	Minimum Measurement Time Analog Measurement Receiver
30Hz-1kHz	10Hz	0.15 sec	0.015 sec/Hz
1kHz-10kHz	100Hz	0.15 sec	0.15 sec/kHz
10kHz-150kHz	1kHz	0.15 sec	0.015 sec/kHz
150kHz-30MHz	10kHz	0.15 sec	1.5 sec/MHz
30 MHz-1GHz	100kHz	0.15 sec	0.15 sec/MHz
Above 1GHz	1MHz	0.15 sec	15 sec/GHz

Table 2-3: Bandwidth and Measurement Time

Frequency Range	Analog Scans Maximum Scan Rates	Stepped Scans Maximum Step Size
30 Hz-1 MHz	0.0333 f_0 /sec	0.05 f_0
1 MHz-30 MHz	0.00667 f_0 /sec	0.01 f_0
30 MHz-1 GHz	0.00333 f_0 /sec	0.005 f_0
1 GHz-8 GHz	0.000667 f_0 /sec	0.001 f_0
8 GHz-40 GHz	0.000333 f_0 /sec	0.0005 f_0

Table 2-4: Susceptibility Scanning

2.3.2 Modulation of Susceptibility Signals

Susceptibility test Signals are modulated according to Table 2-5.

Frequency	Test Level for CW	Modulation
200 MHz – 10 GHz	200 V/m	1 kHz Pulse Modulation, 50% Duty Cycle

Table 2-5: Electric Field Level and Modulation Type

UNCLASSIFIED

Distribution Statement D See Cover Page



2.3.5 Thresholds of Susceptibility

Thresholds of susceptibility are determined as follows:

- (1) When a susceptibility condition is detected, reduce the interference signal until the EUT recovers.
- (2) Reduce the interference signal by an additional 6 dB.
- (3) Gradually increase the interference signal until the susceptibility condition reoccurs. The resulting level is the threshold of susceptibility.

2.3.6 Measuring Frequencies

The entire specified frequency range for each applicable test is scanned.

2.3.7 Test Failure Procedure

A re-test of the EUT is allowed whenever an EMI failure is identified as the result of special test equipment or of an EMI test equipment functional failure, or any time there is a reason to suspect the validity of previously recorded data.

In case of a test failure, the EUT is checked and the cause of failure is determined if possible. In addition, an analysis is conducted to determine if a corrective action has any impact on testing that was performed prior to the failure.

2.3.8 Failure Report

When a relevant EUT failure occurs during a test, failure and resolution report form is initiated. This failure report is submitted to the customer with appropriate data of the failed test. The failure report contains a comprehensive report of the failure to allow the Government the means of identifying and incorporating corrective action.

2.3.9 EUT Installation

The OPC-M2 is battery powered, has a plastic case, and will not have any bonding to the EMI table. Tubing between the oxygen meter and OPC-M2 shall be long enough so that the oxygen meter is outside the test chamber. The oxygen bottle regulator is purely mechanical, though is not an EUT. It is recommended but not required to keep the oxygen bottle outside the test chamber as well. Oxygen tubing and equipment should be arranged such that there is no shielding interposed between the OPC-M2 and the measurement antennas. The OPC-M2 should be located 10 ± 2 cm from the front edge of the ground plane for all susceptibility testing.

2.3.10 EMI Filter Panel

The EUT oxygen tubing enter/exit the shielded enclosure via special EMI panel in the shielded enclosure. There are no electrical cables running to the EUT because it is battery powered.

UNCLASSIFIED

Distribution Statement D See Cover Page

19

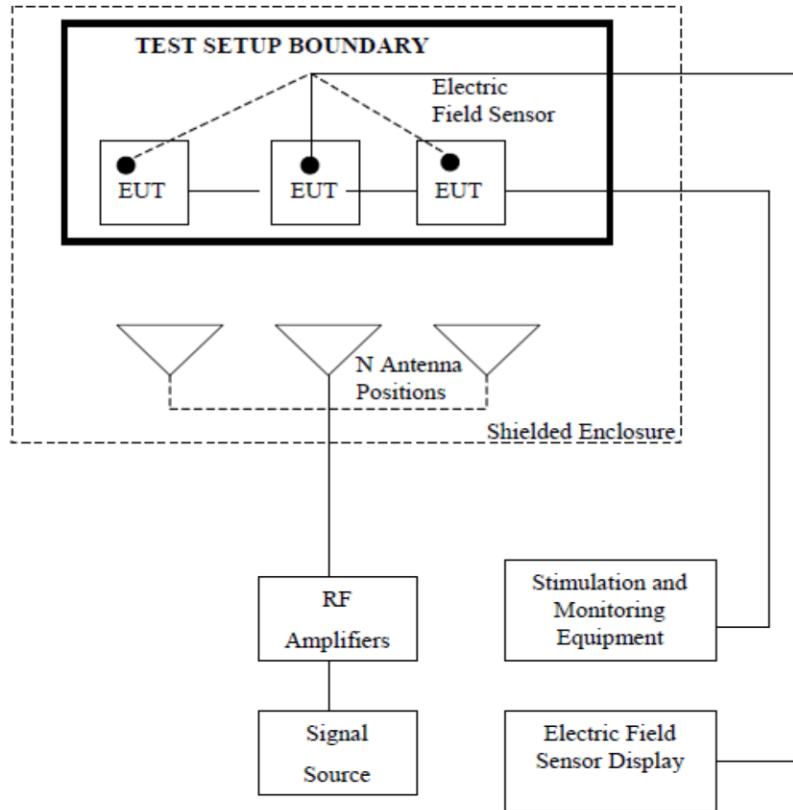

Figure 2-6: RS103 Multiple Antenna Location for Frequency > 200MHz

2.3.11 Polarization

If the antennas are linearly polarized, above 30 MHz, measurements must be performed to measure both horizontal and vertical components of the radiation field. Measurements with the 104cm rod are performed only for vertical polarization.

UNCLASSIFIED

Distribution Statement D See Cover Page

20

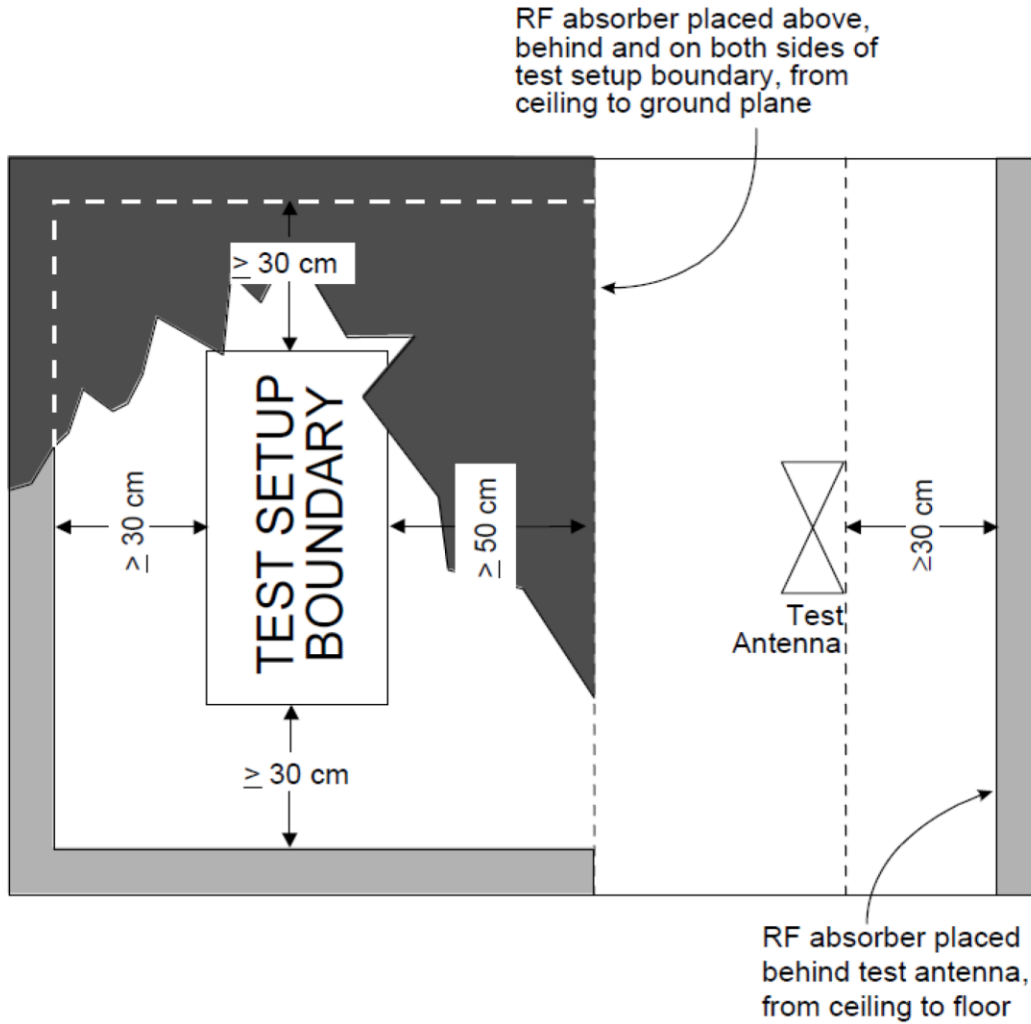

Figure 2-7: RF Absorber Loading Diagram and Spacing Requirements

UNCLASSIFIED

Distribution Statement D See Cover Page

21



2.3.12 Ground Plane

Each shielded enclosure is equipped with a ground plane which has connections to an adjacent wall surface at no greater than 1m spacing. The ground planes are all made of copper solid plate of 2.5m X 1m, with 3mm thickness. The ground planes have bonding resistance to the screen rooms, to which they are attached, of 2.5m or less.

THE EUT WILL BE INSTALLED PLACED ON A NON-CONDUCTIVE TABLE AS IT IS BODY WORN & NOT INSTALLED ON A GROUNDPLANE ON THE AIRCRAFT

*WJR
2/27/24*

2.3.13 Instrumentation

The measuring equipment being used to perform the tests described in this document meet the requirements of MIL-STD-461G. All laboratory equipment is operated as prescribed by the respective instruction manuals unless otherwise specified by this document. This document takes precedence in the event of conflict with instruction manuals or other documents issued by industry. A list of measuring equipment to be used in the performance of EMI testing is included with each test method.

Instrumentation and equipment being used in the measurements for determination of compliance of the EUT, is calibrated, where applicable, in accordance with ISO 10012-1 standard. Instrumentation that are used during this test are within their certification period and are selected based on accuracy requirements specified hereafter.

2.3.14 Test Tolerances and Conditions

Ambient Environmental Test Conditions
Atmospheric pressure 29.921 (+2, - 8) in. Hg.
Temperature 25 +/-10 degrees C.
Relative humidity < 90%.

Test Tolerances

Distance +/-5%
Amplitude, measurement receiver +2dB
Amplitude, measurement system +/-3dB
Time (waveforms) +/-5%

2.3.15 Test Equipment

Test equipment to be used for conducting this test is listed in Table 5-1. Equivalent testing equipment can be used provided the EMI test engineer has approved it for use as alternate test equipment. Equivalent equipment must meet the MIL-STD-461G requirements. Full details of any equivalent test equipment will be detailed in the test report.

2.3.16 Test Set-up

The Test Configuration is shown in Figure 2-9. The test support and monitor equipment are shown in Figure 4-4 and Figure 4-5.

1. Locate the various transmitting antennas and field sensors according to paragraph 4.3.4.
2. Any deviation is fully detailed in the Test Log and approved by the Government EMI Test Engineer prior to commencing this test.

UNCLASSIFIED

Distribution Statement D See Cover Page

22



2.3.17 Test Procedure

2.3.2 Scanning Time

The rates or maximum step size for the frequency scanning are specified in Table 2-4. The dwell time of stepped scans is the greater of 3 seconds or the EUT response time. Scan rates and step sizes are decreased when necessary to permit observation of a response.

2.3.2 Calibration Procedure

Perform a measurement system waveform calibration using the setup shown in Figure 2-8. This calibration process is conducted during the main test for each power amplifier and for each field sensor.

1. Turn on the OPC-M2 using procedure in paragraph 3.1.2, then turn on the test equipment and allow a sufficient time for stabilization.
2. Record the amplitude shown on the E-Field monitor due to EUT ambient and reposition the sensor as necessary, until this level is less than 10% of the smallest applicable field strength required.
3. Generate a field at a selected frequency in the power amplifier range with unmodulated signal and adjust the field to obtain a reading of the field monitor near full scale and record the field strength value (E(1) V/m) and the "PEAK HOLD" value of the spectrum analyzer.
4. Modulate the field as required by the test and adjust the signal amplitude to achieve the same "PEAK HOLD" value of the spectrum analyzer in the previous step. Record the field monitor reading (E(2)V/m)
5. Calculate and record the modulation correction factor of the field monitor as a function of the applicable power amplifier and field sensor according to the formula:
Correction Factor = E(2) / E(1).
6. The reading value of the field monitor during the test is the multiplication product of the required field and the correction factor. Record this value and adjust the signal amplitude to achieve this value.
7. An example of the recorded data is represented in Table 5-2.

UNCLASSIFIED

Distribution Statement D See Cover Page

23

OPC-M2 EMI SOF Qualification Test Plan

Rev DRAFT
 4 January 2023

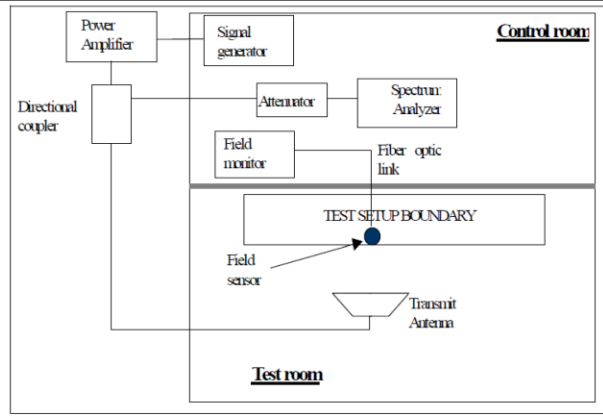

Figure 2-8: RS103 Calibration Test Setup

2.3.18 OPC-M2 Testing Procedure

Perform an EUT radiated susceptibility measurement test using the setup shown in Figure 5-2. The test support and monitor equipment are shown in Figure 4-4 and Figure 4-5. There are two antenna positions will be tested, position one at the HU and position two at the FDD.

1. Power the EUT in test mode IAW paragraph 3.1.2.
2. Set up one of the transmitting antennas and tune the signal source to the start frequency of the antenna. Modulate the signal as required and increase the amplitude slowly until the field monitor indicates the required field (volts/meter) test level as determined by the calibration process, or until EUT susceptibility is observed.
3. Scan the frequency range of the antenna in accordance with the rates or step size specified in subparagraph 5.5.1. Maintain the field levels to achieve the required test level.
4. Repeat step 3 for each polarization of the transmitting antenna.
5. Monitor the EUT for susceptibility per the Failure Criteria of Paragraph 3.2.8.3
6. If susceptibility occurs, determine the threshold levels by using the following method:
 - Reduce the interference signal until the EUT recovers.
 - Reduce the interference signal by an additional 6dB.
 - Gradually increase the interference signal until the susceptibility condition reoccurs. The resulting level is the threshold of susceptibility.
 - Record the level, frequency range of occurrence, frequency and level of greatest susceptibility, and other test parameters, as applicable into the

UNCLASSIFIED

Distribution Statement D See Cover Page



logbook.

7. Repeat step 2 through 6 for each polarization of the antenna.
8. Repeat steps 2 through 7 for each position of the antenna.
9. Whenever the power amplifier or the field sensor is changed, perform the calibration procedure (paragraph 5.5.2) to obtain the field level reading of the field sensor.
10. Repeat steps 2 through 9 for each transmitting antenna to cover the frequency range of the test.

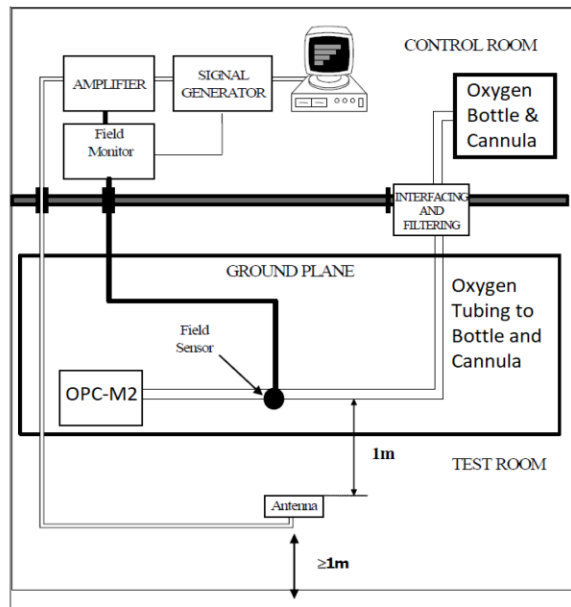

Figure 2-9: RS103 Setup

2.3.19 Radiated Susceptibility RS103 Test Results Format Example

Date		Test Engineer	
Unit nomenclature		Test Site	
Unit S/N		Operation Mode	
Configuration No.			

Table 2-6: Test Results Example Format

UNCLASSIFIED

Distribution Statement D See Cover Page



2.3.20 Test Equipment Example List

Equipment	Manufacturer	Model Number	Asset# / Serial Number	Range
Signal Generator	Rohde & Schwarz	SML-01	100025	10kHz - 1 GHz
Signal Generator	Rohde & Schwarz	SMB-100A	661	100 kHz – 40 GHz
Field Probe	Amplifier Research	FP2000	22924	80MHz-40GHz
Field Probe	Amplifier Research	FP5083	300136	10kHz-1GHz
E-Field Antenna	Amplifier Research	AT-5000	DLS#337	10kHz-30MHz
Biconical Antenna	TDK	HPBA-2510	131123	20-300MHz
Horn Antenna	Amplifier Research	AT4000	22305	200-1000MHz
Horn Antenna	Amplifier Research	AT4002A	305756	1-5GHz
Horn Antenna	Amplifier Research	AT4003	301597	5-7.5GHz
Horn Antenna	Amplifier Research	AT4004	29282	8-18GHz
Amplifier	Amplifier Research	200T1G3A	25476	0.8-2.8GHz
Amplifier	Amplifier Research	200T2G8A	25477	2.5-8GHz
Amplifier	Amplifier Research	200T8G18A	25488	7.5-18GHz
Amplifier	Amplifier Research	1000W1000M7	22243	100-1000MHz
Amplifier	Rhode & Schwarz	BPA-150	2065-9470.90-104856-DG	.01-220 MHz
Field Monitor	Amplifier Research	FM5004	302153	N/A

Table 2-7: RS103 Example Test Equipment and Accessories

Note: Equivalent equipment may be used.

Note: A list of test equipment used and applicable calibration dates will be included in the EMITR.

2.3.21 Test Results

Test results shall be reported in the following format:

- Photographs showing actual EUT and test equipment setup.
- A table of the modulation correction factors. An example is shown in the table below
- Table for the radiated susceptibility test results on the EUT and its associating interconnecting cables as shown in Table 2-9.

UNCLASSIFIED

Distribution Statement D See Cover Page



Amplifier or Field sensor	“PEAK HOLD” dBm	E(1) V/m	E(2) V/m	Correction Factor	Modified Level V/m
IFI + FP2000					
AR + FP2000					
PTC 6341 + FP2080					
PTC 6343					
PTC6348					

Table 2-8: An Example of Modulation Correction Factors

UNCLASSIFIED

Distribution Statement D See Cover Page

27



3 Appendix A – OPC-M2 Operational Testing and Acceptance Test Procedure (ATP) Execution

3.1 OPC-M2 Operational Test

3.1.1 Equipment Required (per OPC-M2 under Test)

- OPC-M2
- Oxygen Bottle with Regulator filled with oxygen (minimum pressure 300 psi, maximum pressure 2000 psi)
- Test Computer(s): Laptop Computer(s) to download logged oxygen sensor data from oxygen test meter
- Oxygen Test Meter
- Cannula and oxygen tubing.

It should be noted that for a long duration test procedure with the OPC-M2 turned on, the oxygen bottle will have to be changed out when it reaches 300psi for a new bottle.

3.1.2 OPC-M2 Operational Test Procedure

The operational testing of OPC-M2 during EMI testing requires the OPC-M2 to be set in test mode prior to beginning any test. Follow the following steps to activate OPC-M2 test mode:

1. Set switch to F/20.
2. Device will power up and begin delivering a pulse of oxygen approximately every five seconds at any altitude until switch position is changed or batteries die or are removed.
3. Verify oxygen is being delivered by monitoring the oxygen test meter.
4. Log all oxygen deliveries over time.
5. Upon completion of a test, download oxygen meter log data and verify oxygen was delivered for the duration of any test where operation during test was required.
6. Identify any susceptibilities if oxygen meter stops working during test by frequency and power level.

In normal operational modes, an inhalation event is required to stimulate delivery of an oxygen bolus to the cannula. Since this is not practical to simulate in a test chamber, all operation during test will be done with the OPC-M2 in test mode. Upon completion of any test event, the acceptance test procedure must be performed and results recorded. Test reports shall include log data of oxygen delivery.

3.1.3 OPC-M2 Acceptance Test Procedure

Upon completion of any test event, the following steps must be performed to verify proper operation of the OPC-M2 in normal mode:

UNCLASSIFIED

Distribution Statement D See Cover Page

29



1. Set rotary switch on OPC-M2 to OFF.
2. Set rotary switch on OPC-M2 to F/20.
3. Device will power up.
4. Verify unit is delivering oxygen from the bottle once about every five seconds by looking at the oxygen meter.

3.1.4 OPC-M2 Pass/Fail Criteria

Successful completion of test is defined by two criteria:

- a. No interruptions found in oxygen delivery during operational test recorded by oxygen meter as defined by paragraph 3.1.2.
- b. Operational test performed per paragraph 3.1.3 is successful.

3.2 OPC-M2 Acceptance Test Procedures (ATP)

The OPC-M2 ATP defined in paragraph 3.1.3 shall be conducted before and after all electromagnetic performance test series to ensure the device is working properly and results recorded for the test report.

The successful ATP at the end of a test series will serve as the entrance criteria for the next test series. This will verify that no degradation has occurred because of electromagnetic testing.

UNCLASSIFIED

Distribution Statement D See Cover Page

30