

REVISION HISTORY			
REV	DA-MO-YR	E. C. O. / APPR.	NOTES
-	17-11-10	PLM	INITIAL RELEASE FOR DESMODROMIC VERSION
A	17-04-12	PLM	REVISED DRAWING FOR NEW PILOT REG & FILL STATION

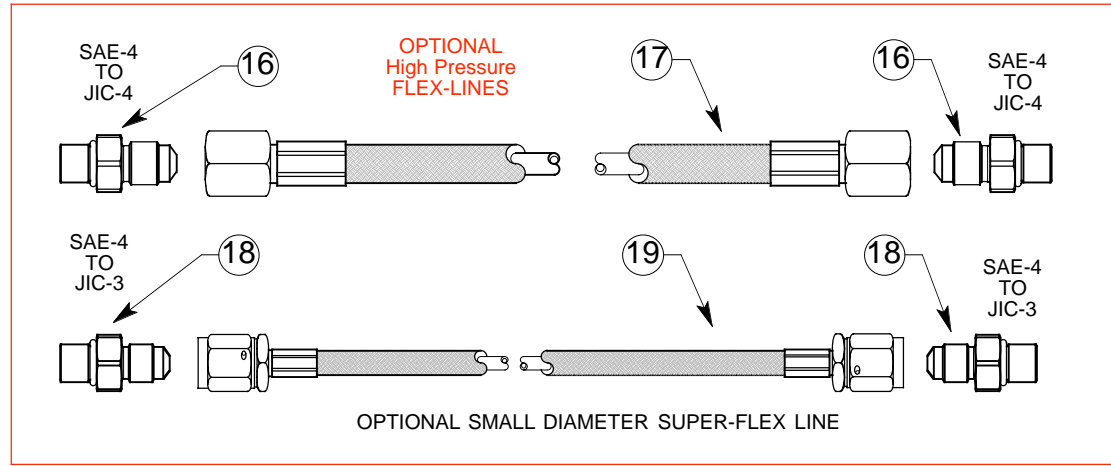
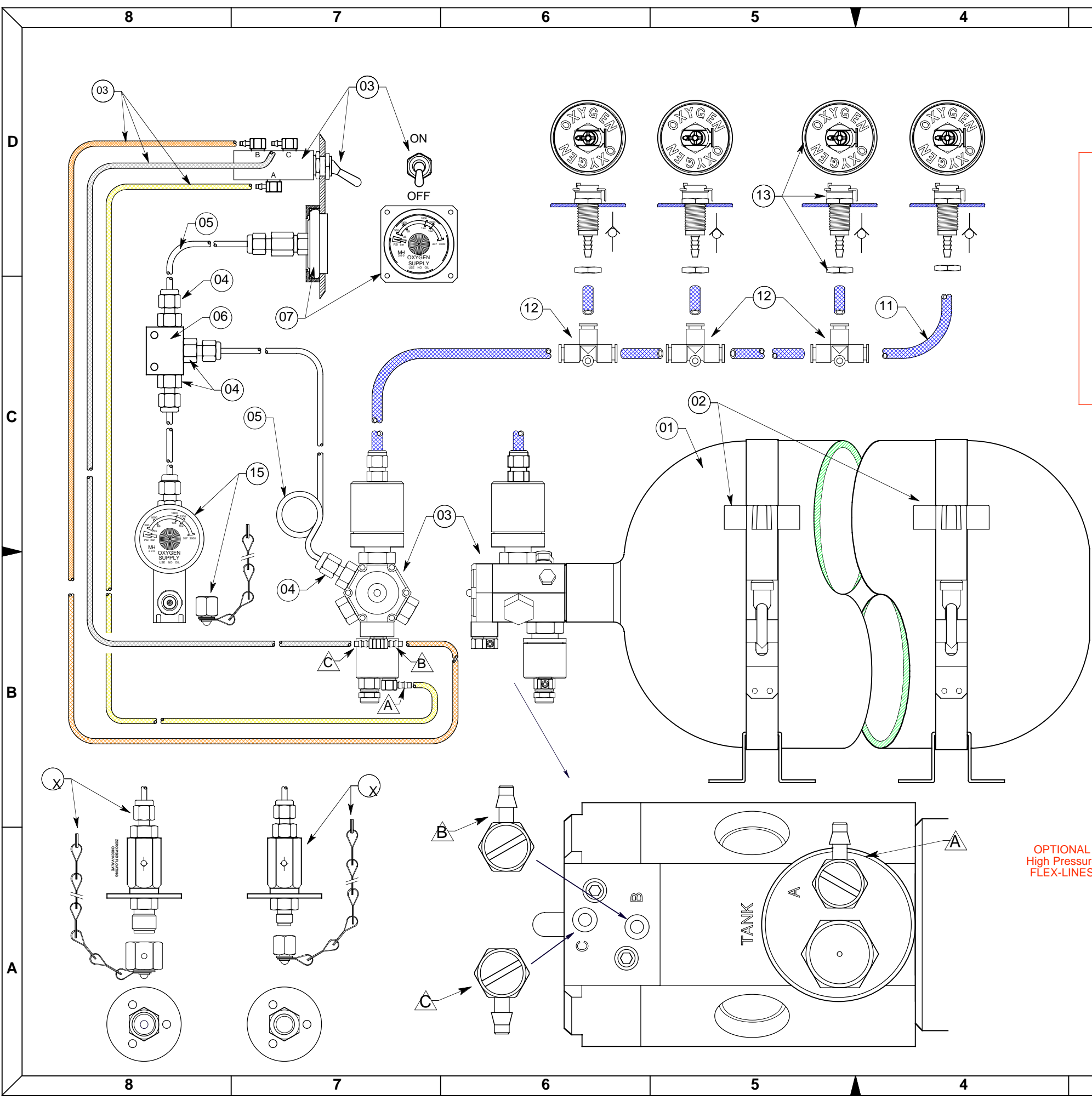

REF	QTY	PART DESCRIPTION	ITEM, DWG. OR PART NO.
01	01	CYLINDER	00CYL-XXXX-00
02	01	CYLINDER MOUNTING KIT FOR LINE ITEM 01	00CMK-XXXX-02
03	01	RCV/RCR KIT, SWITCH & TUBING KIT (DESMODROMIC)	ARCVR-0102-00
04	04	SAE-4-M TO 1/8" OD COMPRESSION TUBE FITTING	00HDW-0108-00
05	25'	1/8" O.D. COPPER TUBING COIL KIT	19605-0002-00
06	01	4X4X4 SAE-4 HP TEE UNION MANIFOLD	00MAN-0012-00
07	01	MH-300 GAUGE W/BEZEL KIT, 1/8" COMP FITTING	00CPG-0030-00
			APVRO-0150-00
11	30'	6MM O.D. POLYURETHANE TUBING COIL KIT	00HDW-0014-30
12	03	1" 6X6X6 mm. POLYURETHANE TUBE UNIONS ('Y' OPTIONAL)	00HDW-1328-00
13	04	BULKHEAD STYLE O2 OUTLET KIT (WITH CHECK-VALVE)	00CPC-0018-01
14			
15	01	AN800-3 BH FILL KIT 1/8" TUBE (MS22066)	00BLT-1022-01
16	02	SAE-4 TO JIC-4 FITTING ADAPTER (OPTIONAL)	00HDW-1381-01
17	01	JIC-4 STD. DIA. HP FLEX-LINE (SPECIFY LENGTH)	00HDW-0011-XX
18	02	SAE-4 TO JIC-3 FITTING ADAPTER (OPTIONAL)	00HDW-XXXX-XX
19	01	JIC-3 SMALL DIA. HP FLEX-LINE (OPTIONAL)	00HDW-XXXX-XX

OPTIONAL High Pressure FLEX-LINES

ISSUED:		RCV DESMO WITH GAUGE & FILL	
DRAWN: PLM		DWG. #: ØRCVØ-055-002	
ENGINEER: PLM		REV A	
APPR:		SIZE B	SHEET 1 OF 1
		DO NOT SCALE DRAWING	

THIRD ANGLE PROJECTION

[ KC ]  
00

NUMBER OF KEY CHARACTERISTICS IN THIS DRAWING / DOCUMENT PER MH DOC: ESR-001

MOUNTAIN HIGH E&S CO. REDMOND, OR. USA