

GENERAL SPECIFICATIONS

MATERIAL: CDA BRASS B124/CA377 PER SAE J514, J530
 PRESSURE RATING: 3000 PSIG.
 SAFETY FACTOR: 2:1
 WEIGHT: 1.7 oz. (48 g)
 CLEAN: PER AIR 1176A SEC. 5 (CGA G-4.1)
 MFG. / VEN. CODE: MH

REVISION HISTORY			
REV	DATE	E. C. O. / APPR.	NOTES

SOURCE CONTROL DOCUMENT FOR REFERENCE ONLY

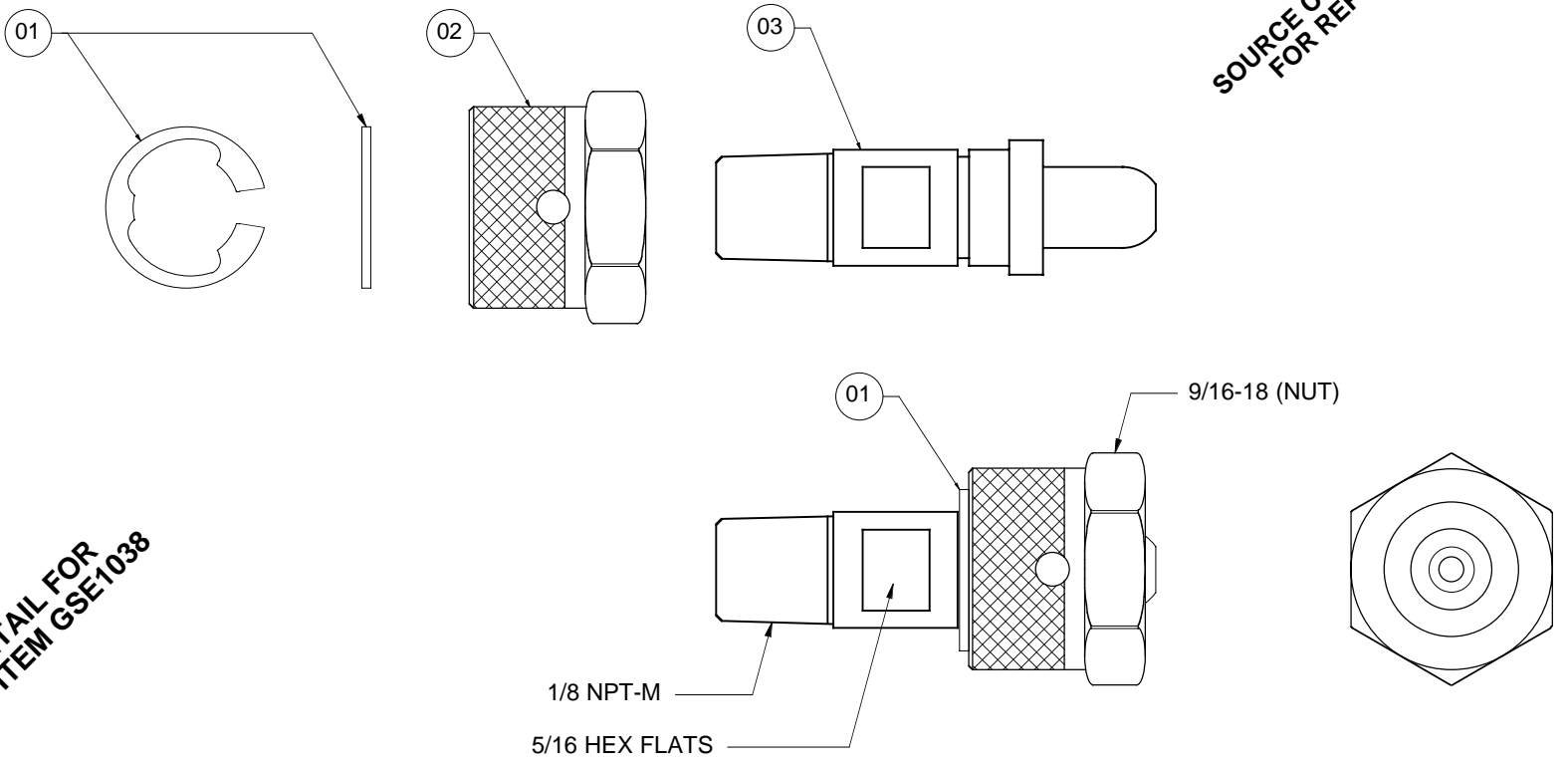

ASSY. DETAIL FOR PRODUCT ITEM GSE1038

REF	QTY	DWG / PART NO.	REV	SUB-ASSY.	NOMENCLATURE
01	01	9005-002	-	-	RING, RETAINING
02	01	TA01-201	-	-	NUT, HEX 9/16-18 (VENT)
03	01	TA01-205	-	-	FITTING, 1/8 NPT-M TO AS1219 (SCOTT, AIRLINE)

UNLESS OTHERWISE SPECIFIED DIMS ARE IN INCHES.
 TOLERANCES ARE:
 0.X ±0.015 ANGLES FRACTIONS 63 ✓
 0.XX ±0.010 ± 0.5° ± 1/64
 0.XXX ±0.005
 INTERPRET DIM AND TOL PER ASME Y14.5

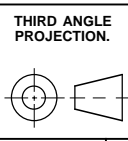

THIRD ANGLE PROJECTION.
 <CR> KEY CHARACTERISTICS NO. -0-
 <MA> PER CORP. DOC: ESR-001
MH MOUNTAIN HIGH E&S CO. REDMOND, OR. USA

ISSUED:	06-15-01
DRAWN: PLM	06-15-01
ENGINEER: PLM	06-15-01
APPR: PLM	06-15-01

FITTING, 1/8 NPT-M TO AS1219 (SCT)	
DWG. #: TA01-113 (SCD)	REV -
SIZE A	SHEET 1 OF 1
DO NOT SCALE DRAWING	