

REVISION HISTORY			
REV	MO-DA-YR	E. C. O. / APPR.	NOTES
-	12-10-00	PLM	INITIAL RELEASE

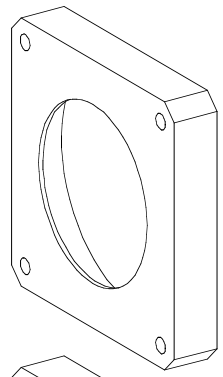

VIEW OF REAR

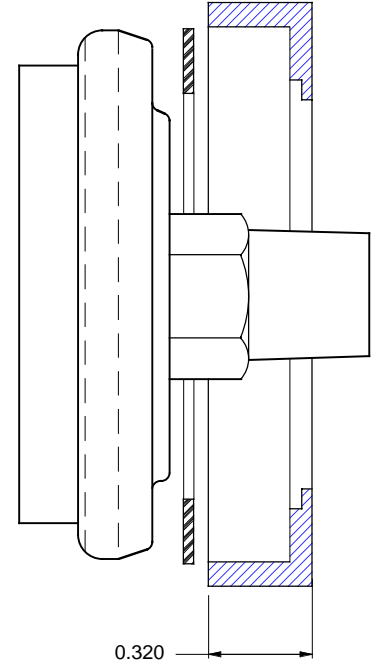
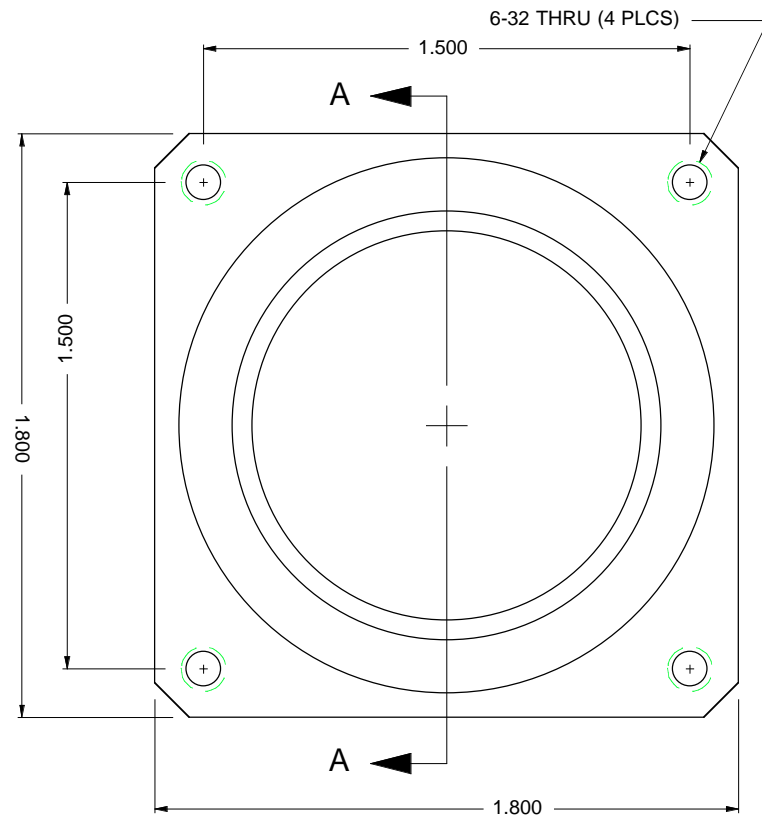
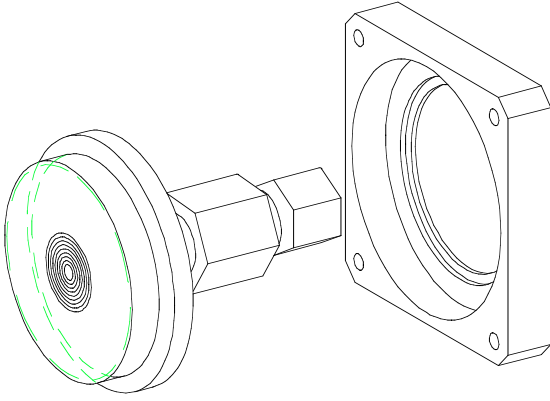
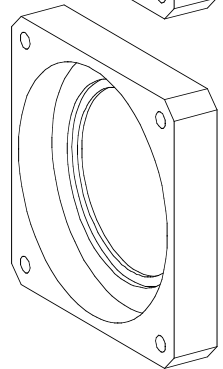

VIEW OF FRONT

UNLESS OTHERWISE SPECIFIED DIMS ARE IN INCHES. TOLERANCES ARE:				THIRD ANGLE PROJECTION.	<CR> KEY CHARACTERISTICS PER CORP. DOC: ESR-001	NO. .
0.X	±0.015	ANGLES	FRACTIONS			MOUNTAIN HIGH E&S CO REDMOND, OR. USA
0.XX	±0.010	± 0.5°	± 1/64			
0.XXX	±0.005					
INTERPRET GD&T DIMS AND TOLS PER ASME 14.5						
ISSUED:	DATE	MATERIAL:	NOTE 1	GAUGE MOUNT 1.5 (SCD)		
DRAWN: PLM	08-22-00	FINISH:	NOTE 2	DWG. #: MH30-050-00		
ENGINEER: PLM	08-22-00	CLEAN:	NOTE 3	REV -		
APPR:	DATE	MARKING:	NOTE 4	SIZE A	SHEET 1 OF 1	DO NOT SCALE DRAWING